



MAXIM
Crane Works, L.P.
1-877-MAX-LIFT

TECHNICAL DATA | IMPERIAL

AC 5.220-1

250 US TON MAX. CRANE CAPACITY

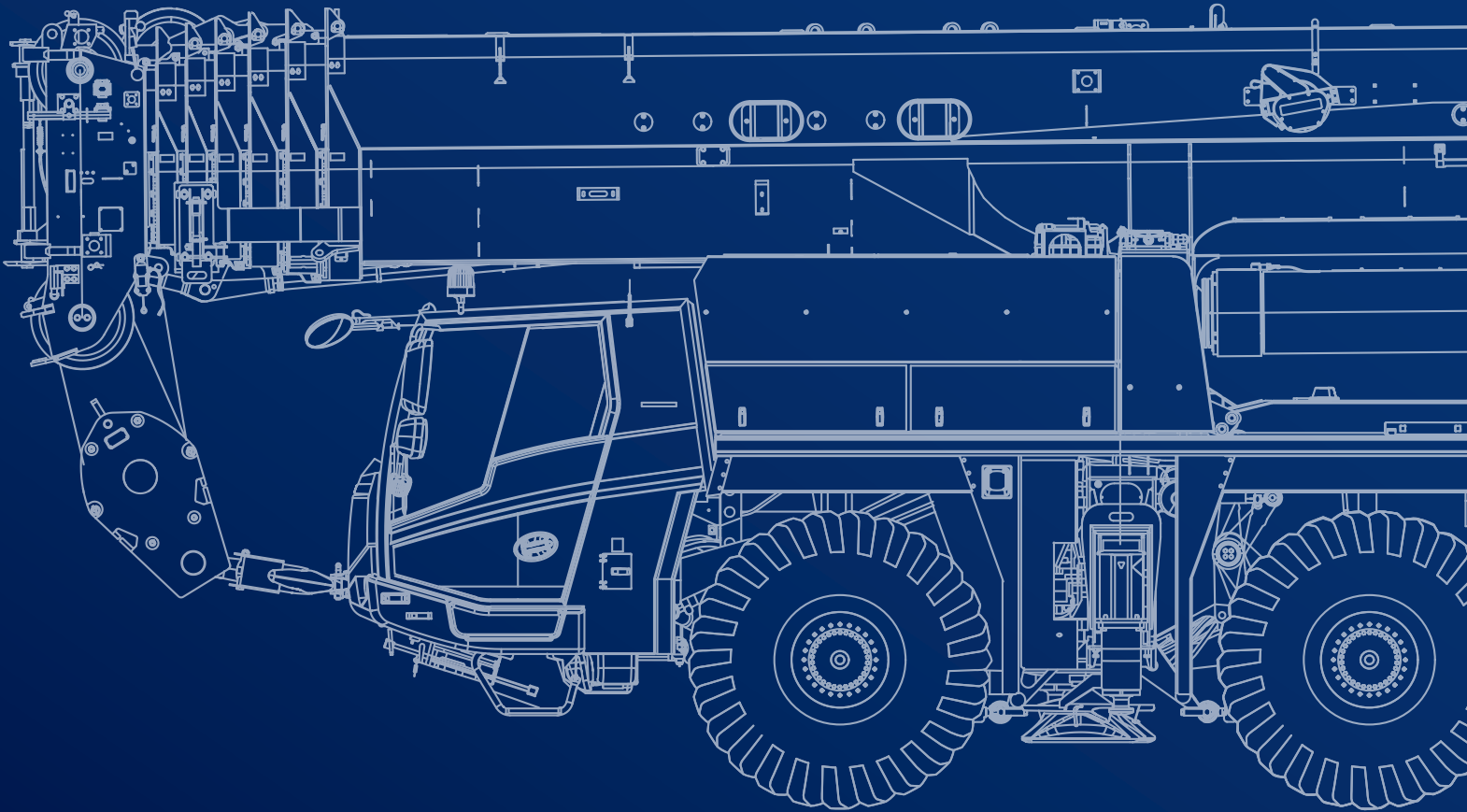

July 2022. Unless otherwise specified, all information in this brochure refers to a standard crane equipment, and it is intended as general information only. No liability is assumed. Errors reserved. Product specifications and prices are subject to changes without notice. The photographs and/or drawings in this brochure are for illustrative purposes only. For correct and safe crane operation, the original operating manual and lifting capacity charts are essential. Failure to follow the corresponding Operator's Manual when using our equipment or failure to otherwise act responsibly may result in property damage, serious injury or death. The sole warranty applicable with respect to our equipment is the standard warranty as per general terms and conditions of sales and service (ask your local Tadano dealer for details), and Tadano makes no other warranty, express or implied. All rights reserved. Any use of the trademarks, logos, brand names and model names used herein is prohibited.

© Tadano Ltd. 2022

Contents

General	5
Vehicle dimensions	6
Boom combinations	7
On-road and off-road driving	9
Axle loads	10
Speeds and gradeability	10
Steering	10
Transportation	11
Counterweight	12-15
Configurations	12, 14
Jib	16-18
Operation	19
Main boom	21
Slewing	21
Hoist	21
Outrigger cylinders	21
Hook Blocks	21
MB: Main boom	22-27
FJ: Folding swing-away jib	28-40
HTLJ: Hydraulically telescopable and tiltable jib	42-47
FJ: Runner	48-50
Notes to Lifting Capacity	52
Technical Description	53
Basic machine	54
Additional equipment	55

Key



	Counterweight		Boom telescoping
	Lifting capacities on outriggers · 360°		Boom elevation
	Radius		Working speeds
	Main boom		Slewing
	Folding swing-away jib		Max. line pull
	Runner		Rope diameter
	Max. axle loads		Rope length
	Mechanism		Hook block
	Tires		Number of lines
	Hook block		Possible load of hook block
	Hoist		Weight of hook block
	Travel speed		Distance head sheave axle – hook ground
	Gradeability %		Number of sheaves in hook block
	Off road / On road		Max. outrigger load
			Length of stroke (support cylinders)

GENERAL TECHNICAL DATA

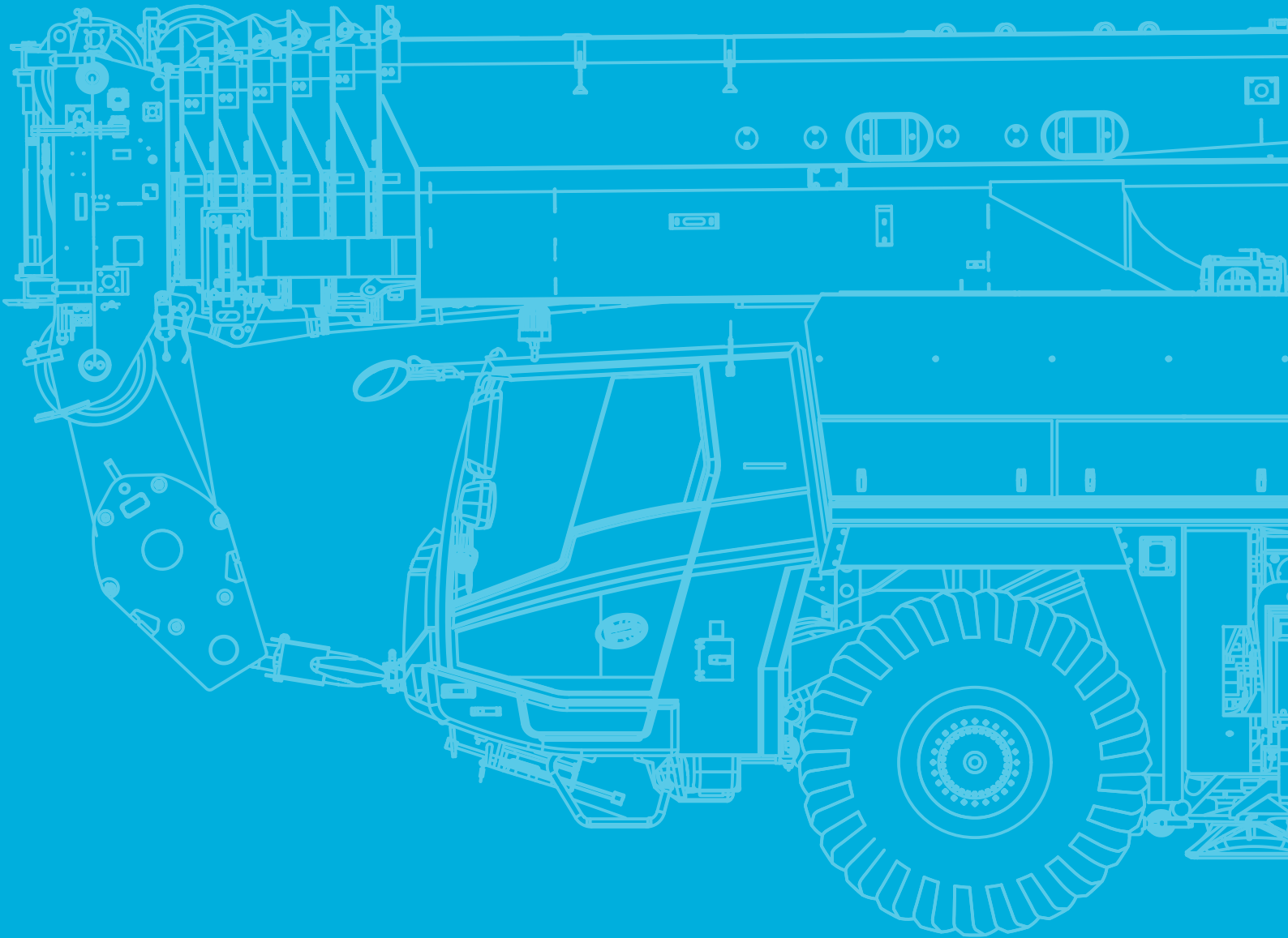

General

Vehicle dimensions

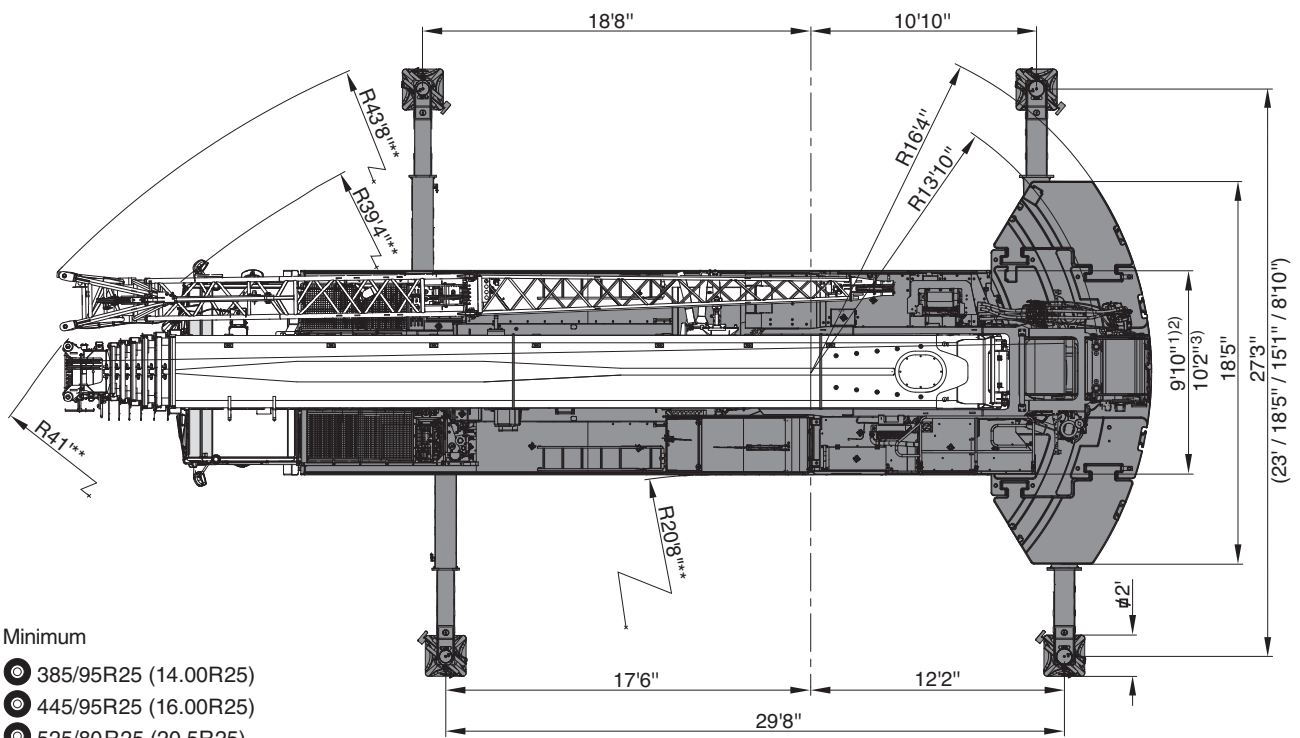
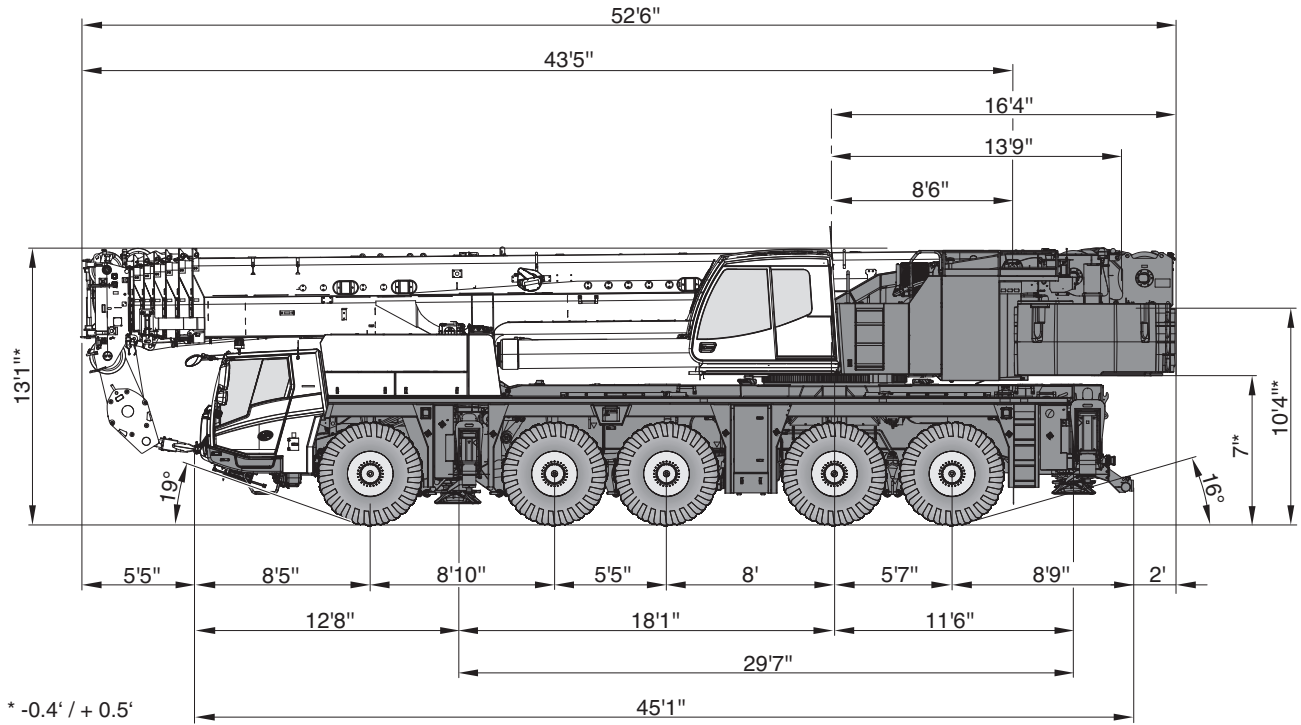

** Minimum

- 1) 385/95R25 (14.00R25)
- 2) 445/95R25 (16.00R25)
- 3) 525/80R25 (20.5R25)

General



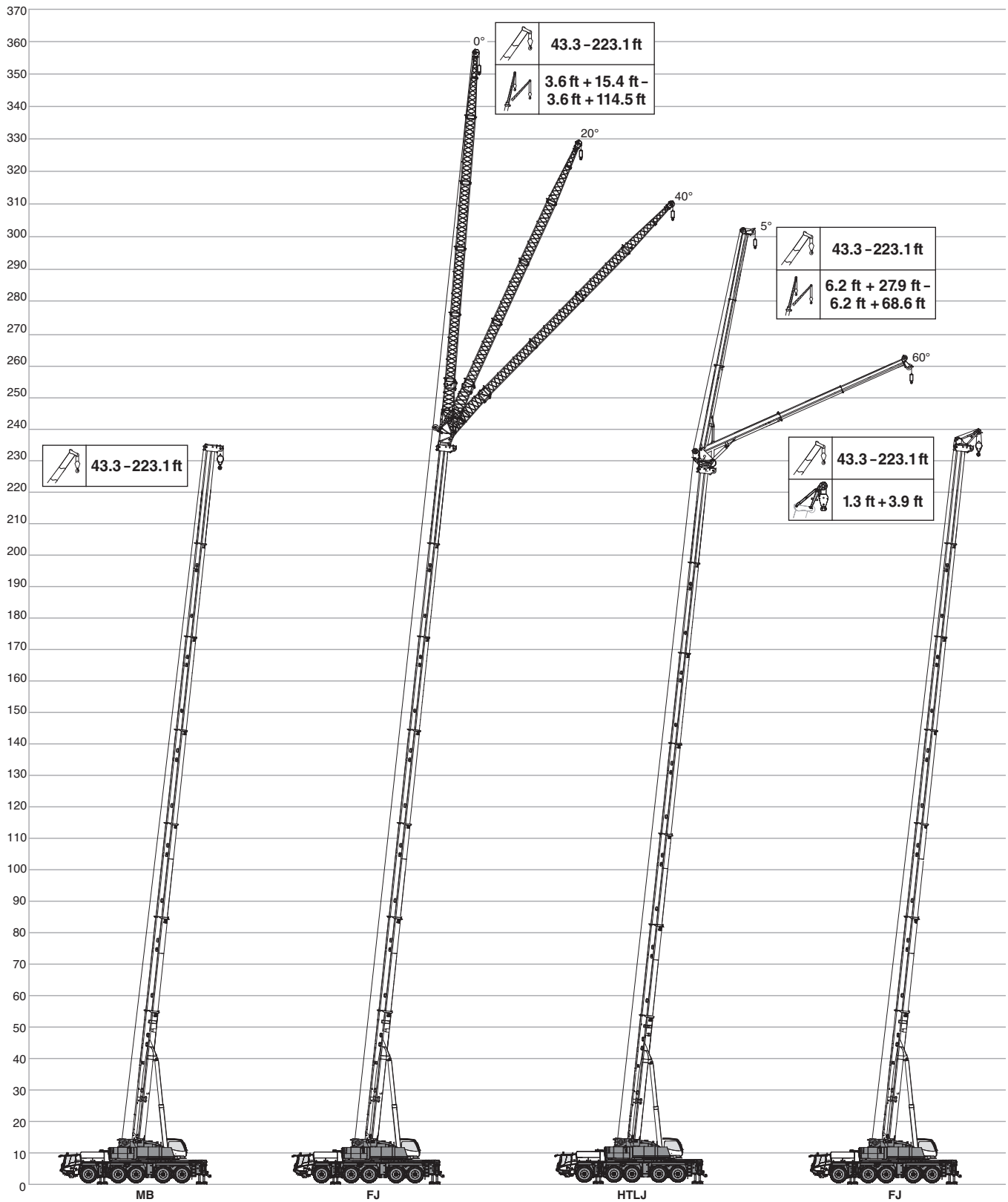

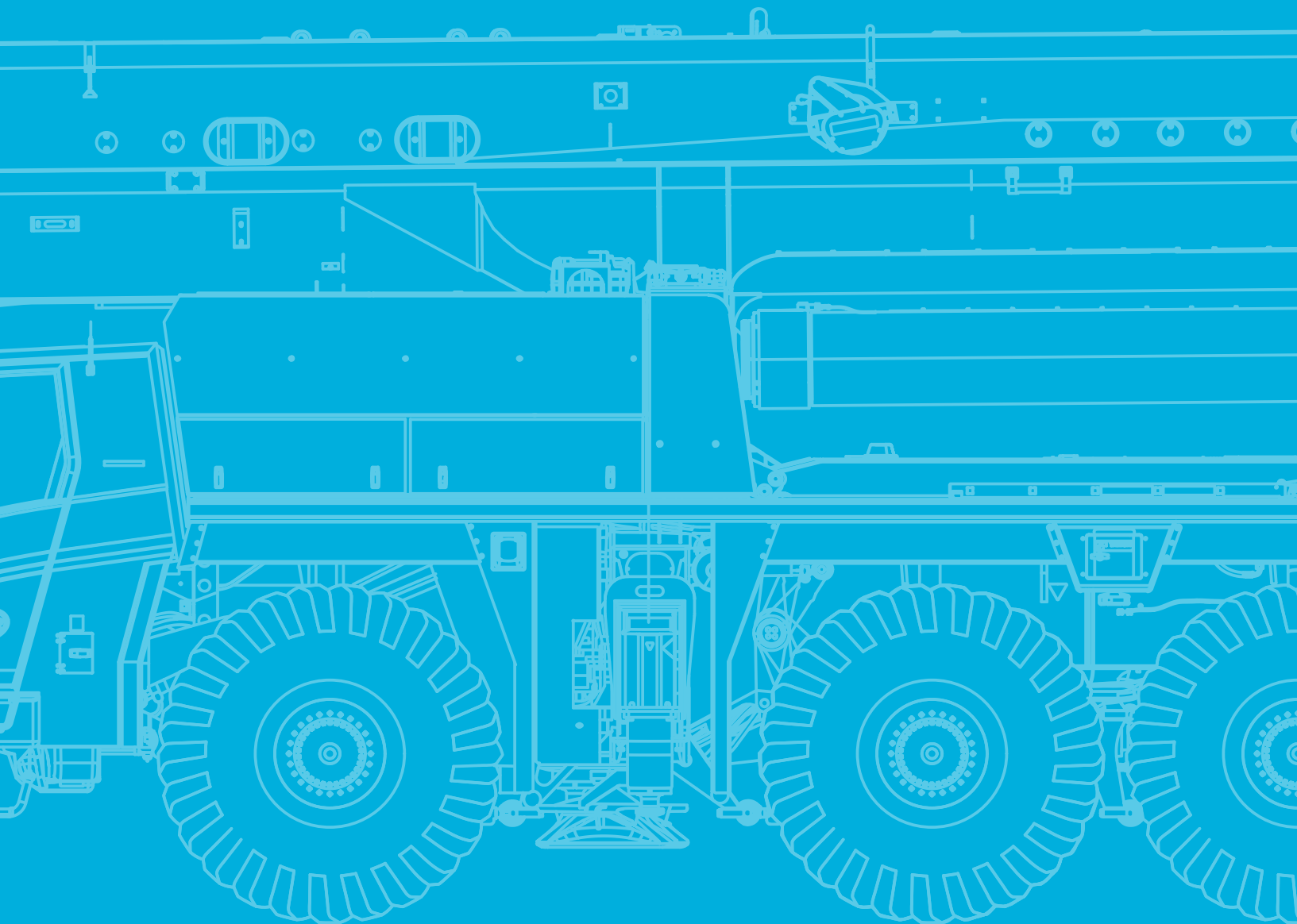

Boom combinations











TECHNICAL DATA FOR ON-ROAD AND OFF-ROAD DRIVING









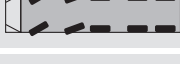

On-road and off-road driving

Axle loads						
	Total					
< 26,500 lbs	< 132,300 lbs	10 x 8	445/95R25	176,400 lbs	–	0 lbs
< 36,400 lbs	< 178,600 lbs	10 x 8	445/95R25	176,400 lbs / 22,050 lbs	3.6 ft + 35.8 ft	40,300 lbs

Speeds and gradeability				
	385/95 R 25 14.00 R 25	445/95 R 25 16.00 R 25	525/80 R 25 20.50 R 25	
 	64 %	57 %	57 %	
 	72 %	63 %	63 %	
 	49.7 mph ¹⁾	52.8 mph ¹⁾	52.8 mph ¹⁾	
 	23.6 mph ¹⁾	26.1 mph ¹⁾	26.1 mph ¹⁾	

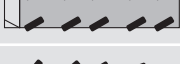
¹⁾ Depending on tire type, size and country specific legislation

Steering	
	 v < 18.6 mph
	 18.6 mph ≤ v ≤ 31.1 mph
	 v > 31.1 mph
	 Manually steered
	 Minimum turning radius
	 Crab steer mode
	 Rear veering suppression

TECHNICAL DATA FOR TRANSPORT

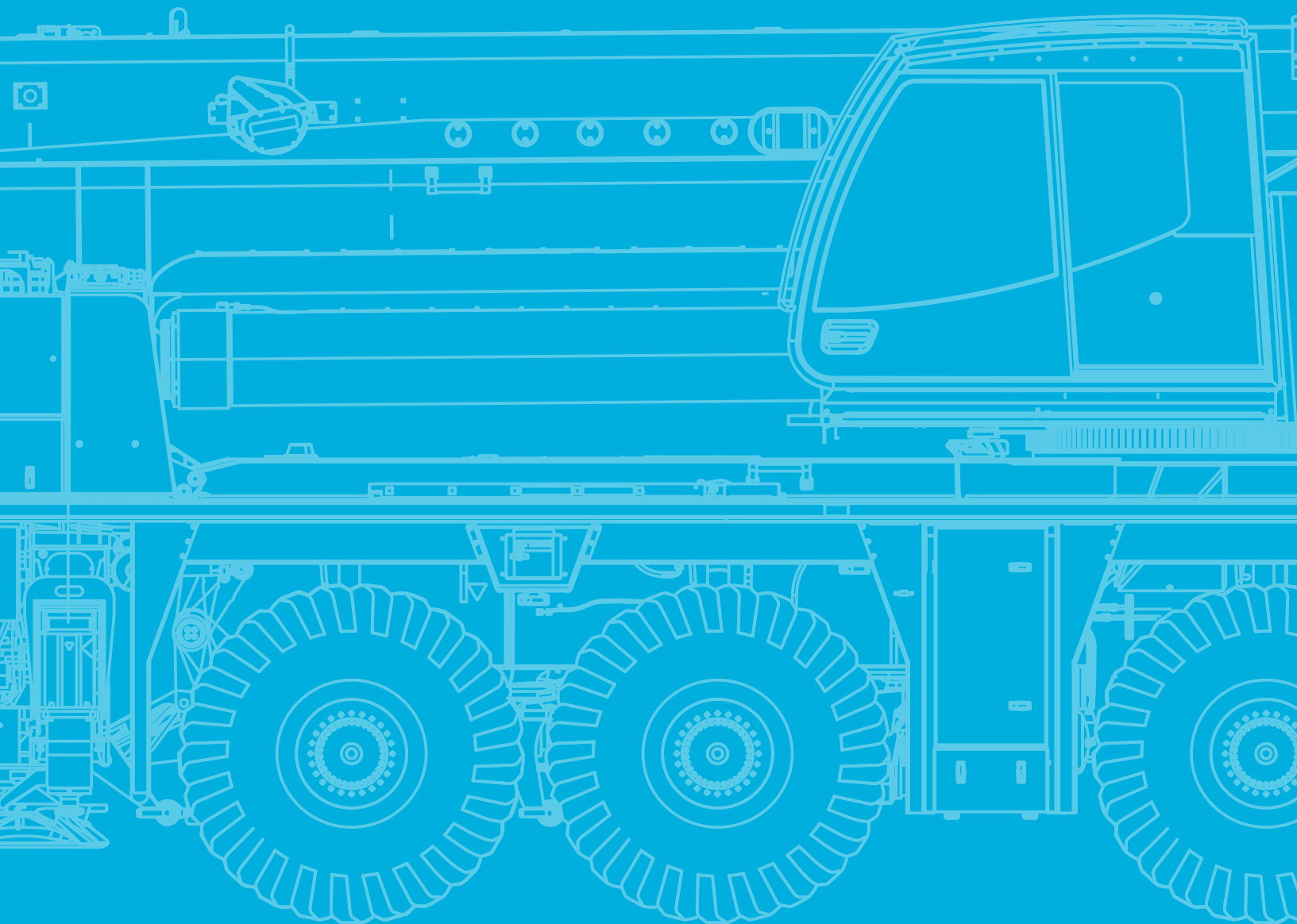

Transportation

Counterweight

STANDARD

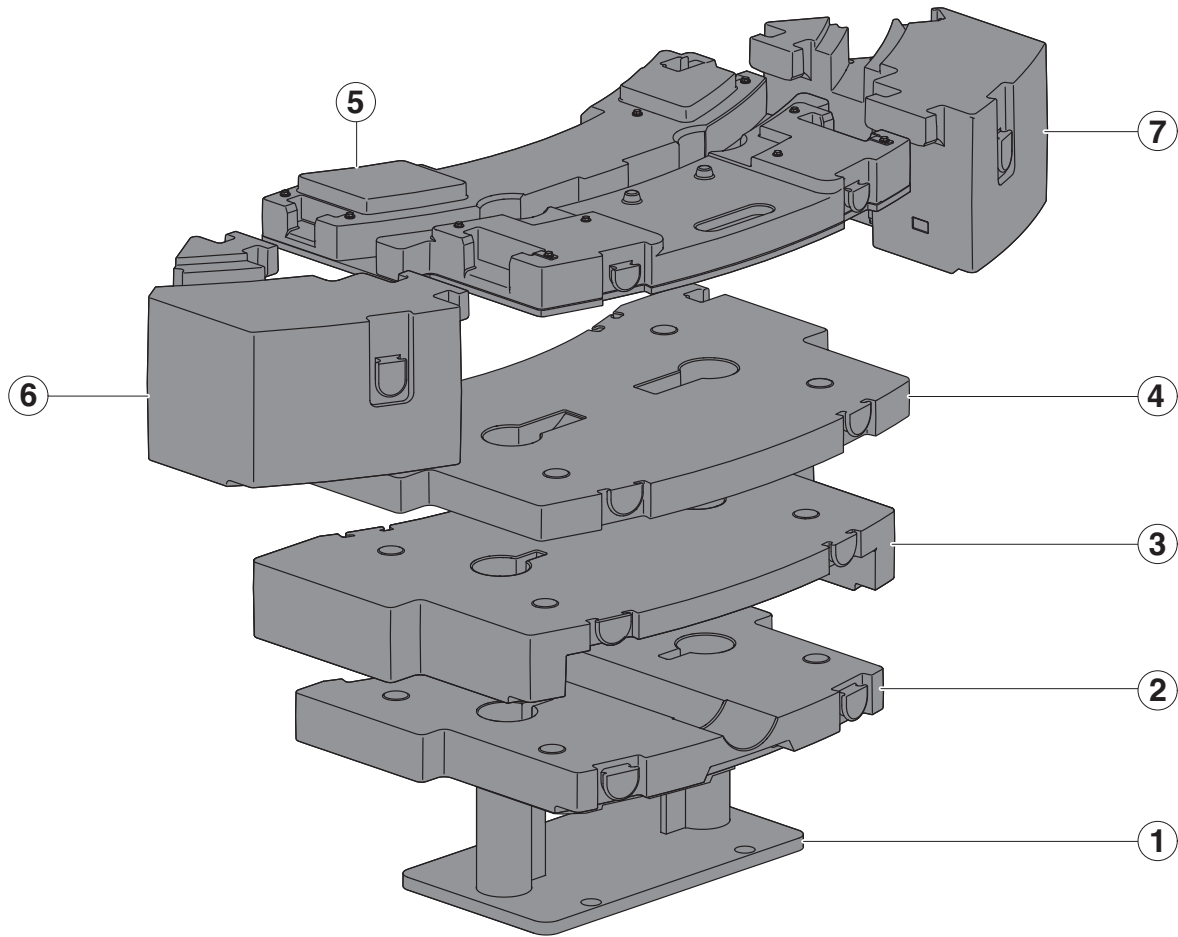

Configurations

	26,500 lbs	51,800 lbs	77,200 lbs	103,600 lbs	156,500 lbs
① 4,400 lbs	1	1	1	1	1
② 22,050 lbs	1	1	1	1	1
③ 25,400 lbs		1	1	1	1
④ 25,400 lbs			1	1	1
⑤ 26,500 lbs				1	1
⑥ 26,500 lbs					1
⑦ 26,500 lbs					1

Transportation

Counterweight

1

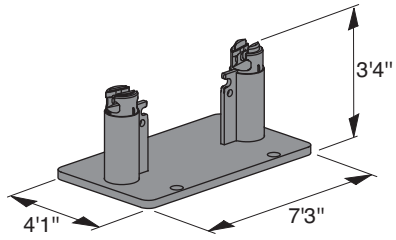

2

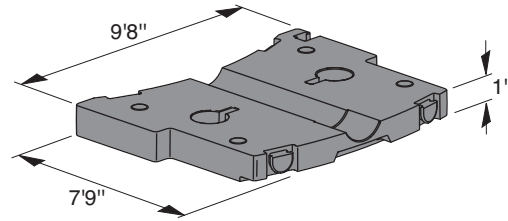

3

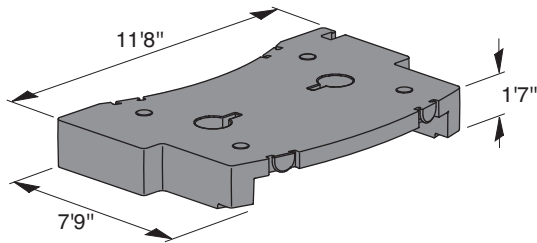

4

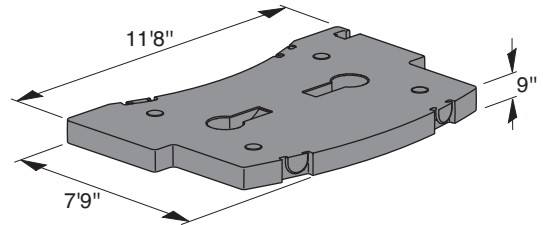

5

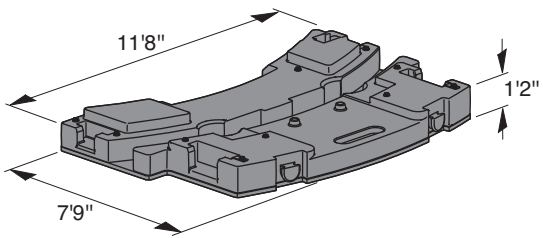

6

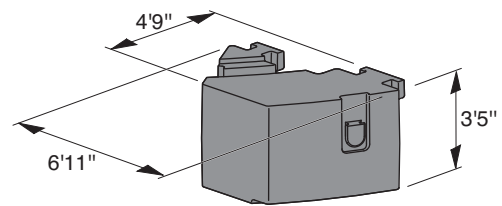

7

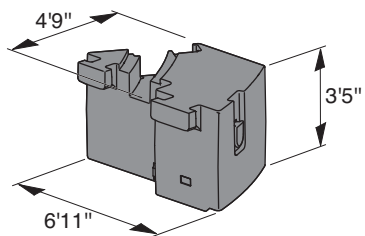

Transportation

Counterweight

SPECIAL

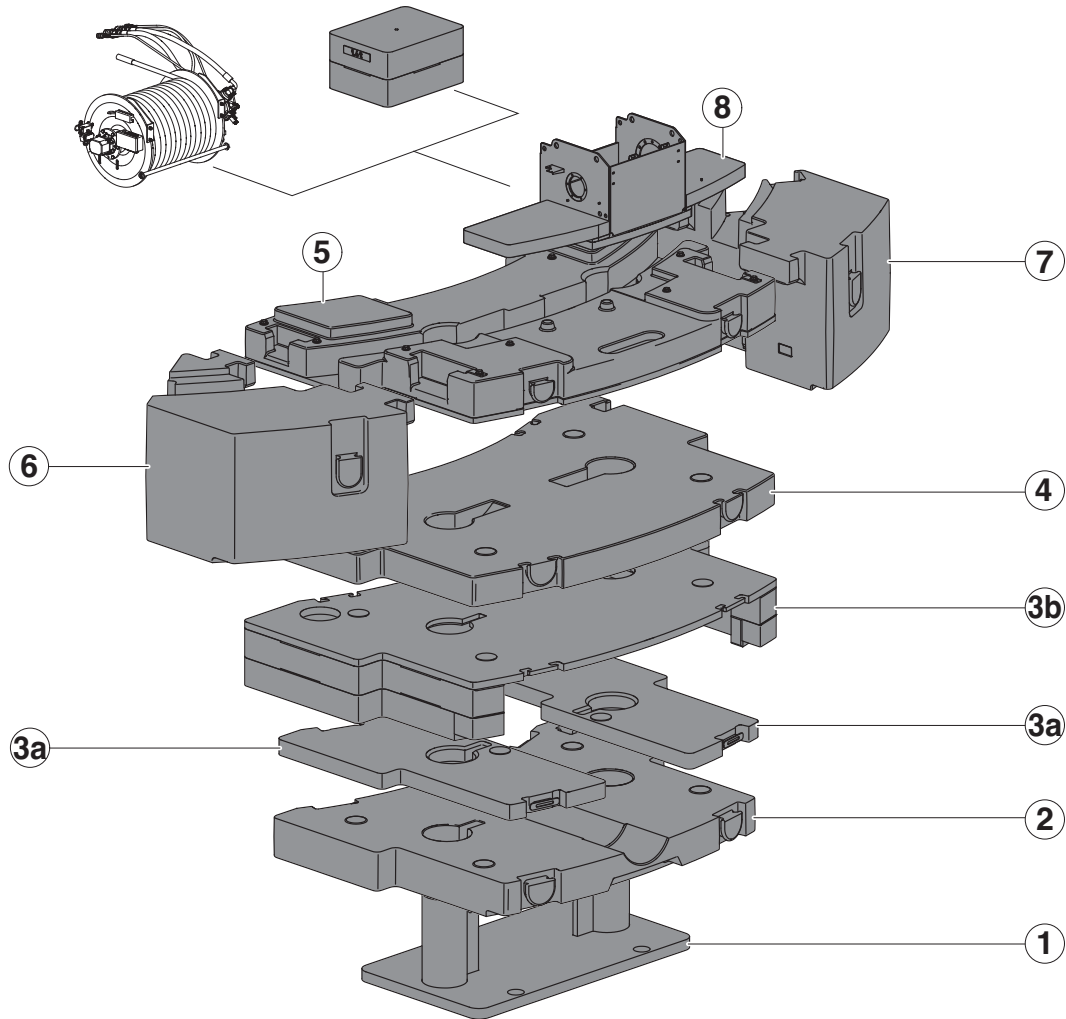

Configurations

	40,300 lbs	51,800 lbs	77,200 lbs	103,600 lbs	156,500 lbs
① 4,400 lbs	1	1	1	1	1
② 22,050 lbs	1	1	1	1	1
③a 3,750 lbs	2	2	2	2	2
③b 11,500 lbs		1	1	1	1
④ 25,400 lbs			1	1	1
⑤ 26,500 lbs				1	1
⑥ 26,500 lbs					1
⑦ 26,500 lbs					1
⑧ 6,400 lbs	1	1	1	1	1

Transportation

Counterweight

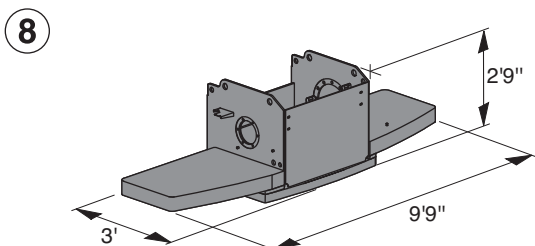
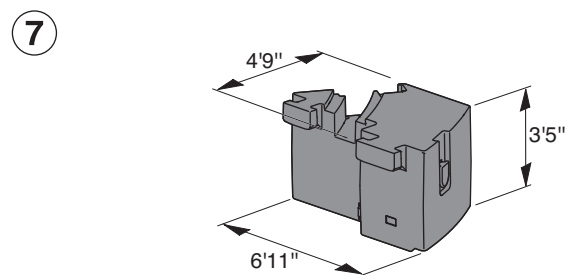
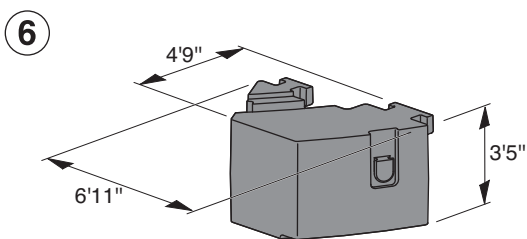
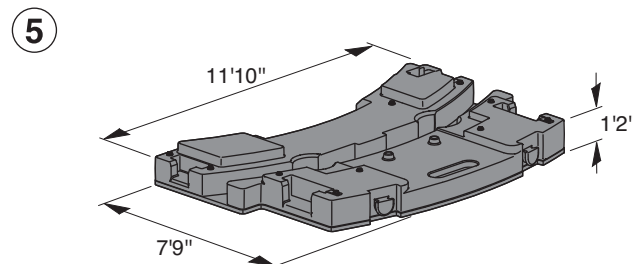
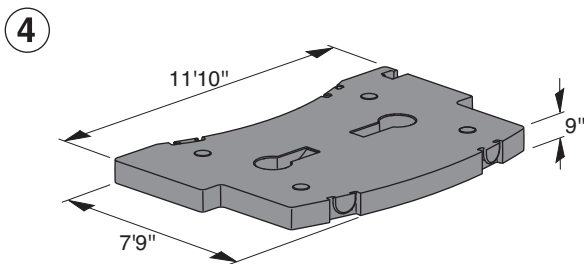
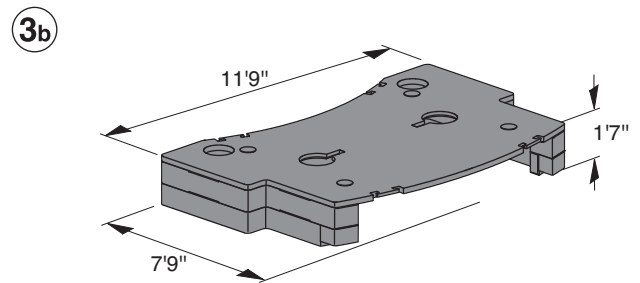
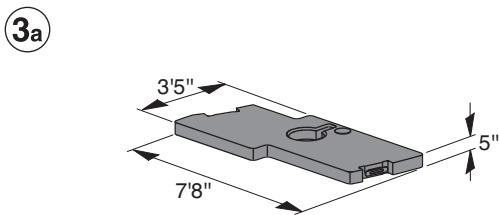
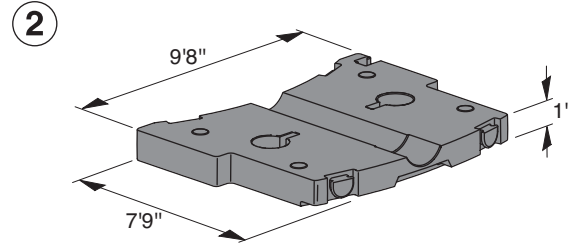
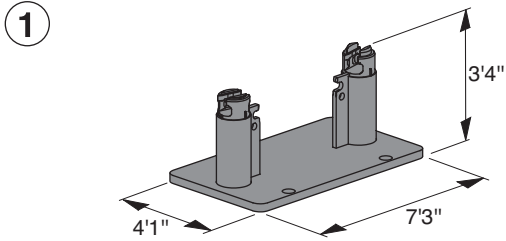

Transportation

Jib

FJ

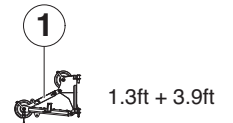
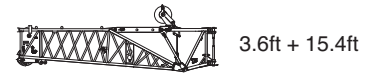
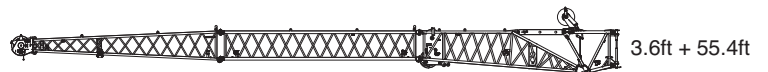
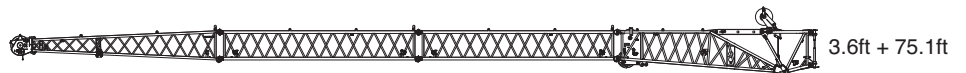
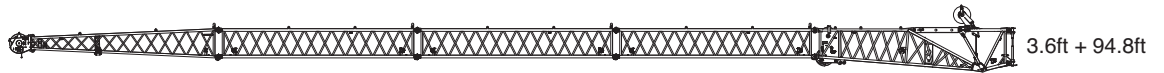
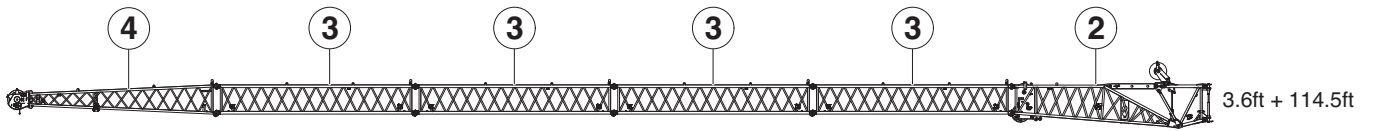

Transportation

Jib

1

lbs
750

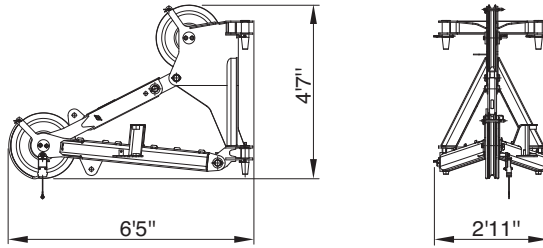

2

lbs
2,200

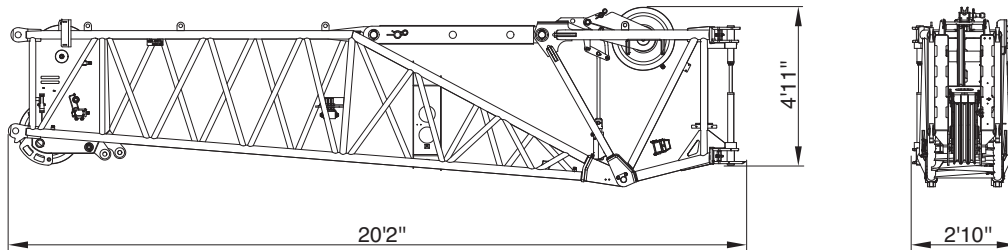

3

lbs
950

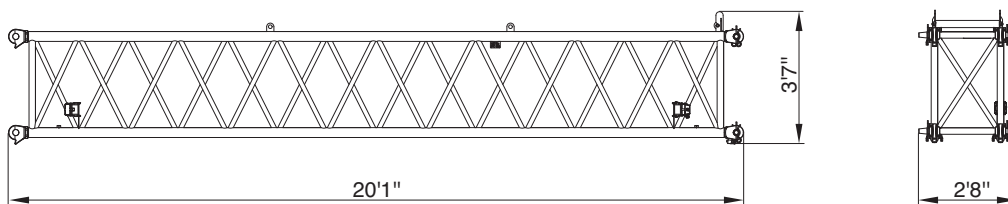

Transportation

Jib

4

lbs
850

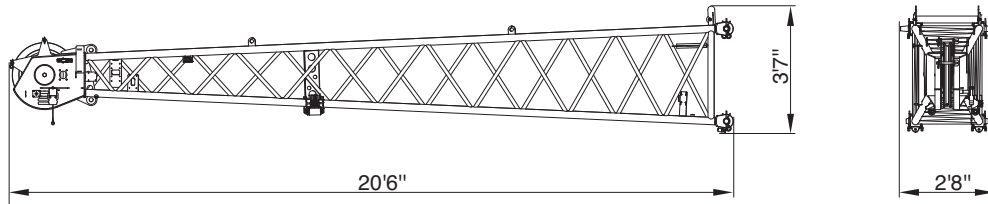

lbs
10,750

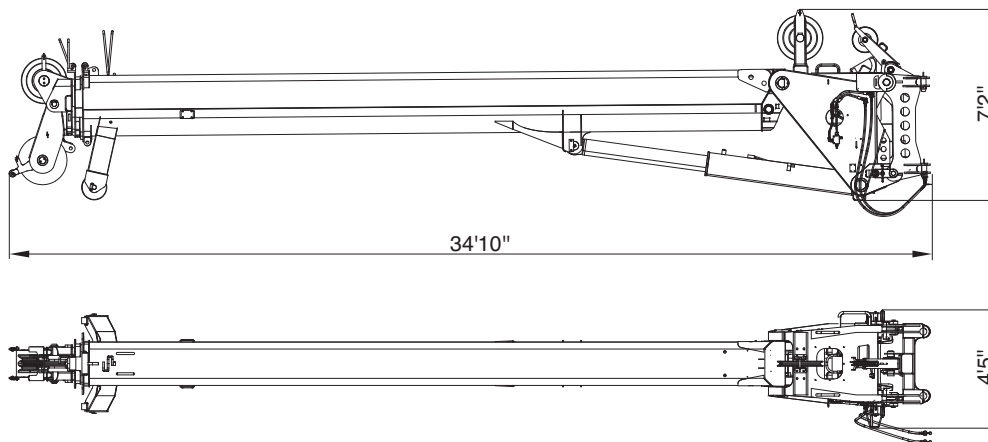

TECHNICAL DATA FOR OPERATION

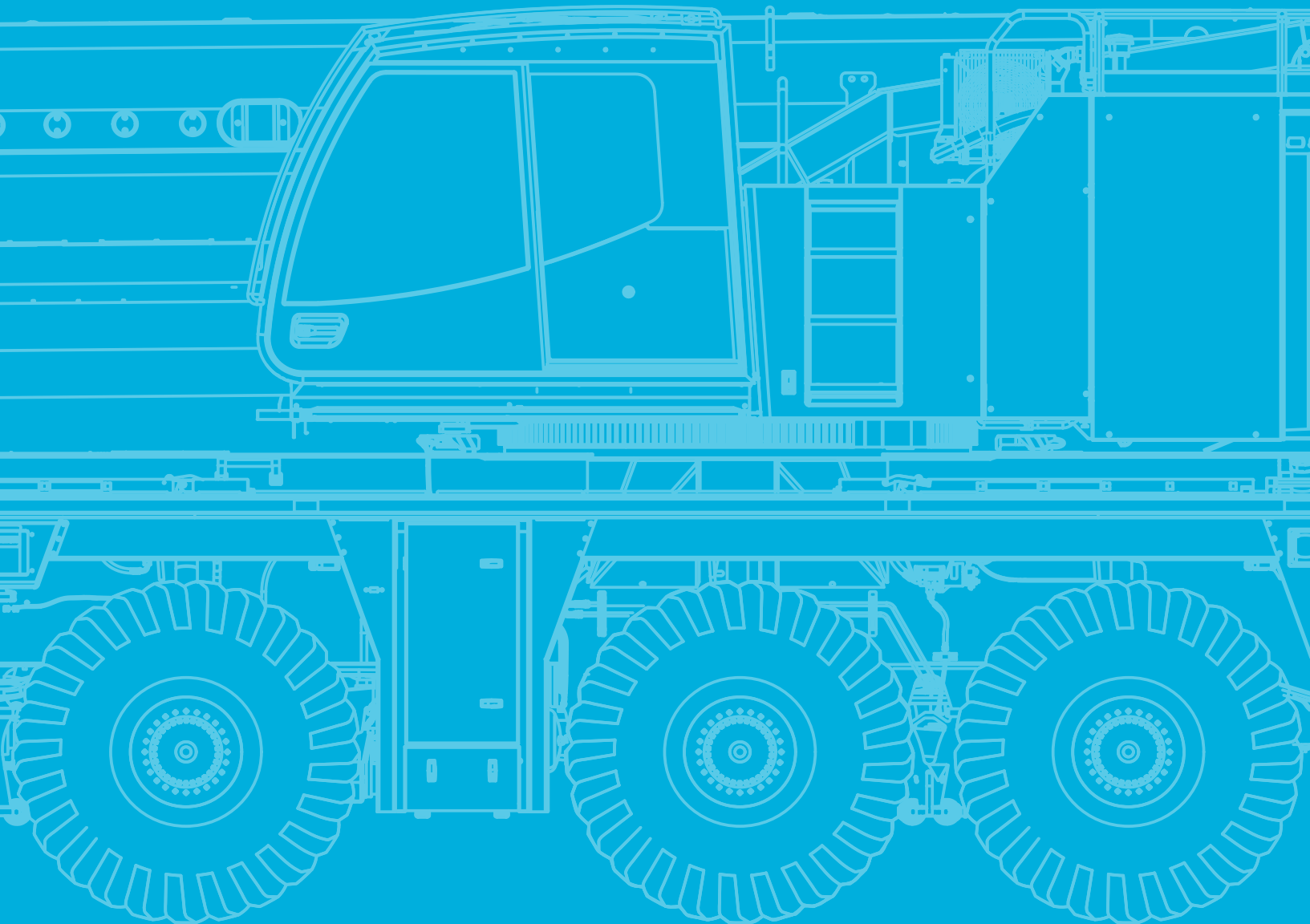

Operation

Main boom



approx. 550 s (43.3 ft - 223.1 ft)



approx. 58 s (-0,8° - 83,5°)

Slewing



0 - 1,2 min⁻¹

Hoist



1

420 ft/min

22,046 lbf

0.83"

1050 ft

2

420 ft/min

22,046 lbf

0.83"

1050 ft

Outrigger cylinders

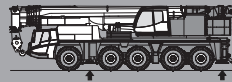

187,400 lbs

271,200 lbs



17.5"

22.0"

Hook Blocks



22,050 lbs

22,050 lbs

–

1

660

70,500 lbs

64,800 lbs

1

3

990

176,400 lbs

149,700 lbs

3

7

1,760

275,600 lbs

232,400 lbs

5

11

2,540

352,800 lbs

313,300 lbs

7

15

2,870

441,000 lbs

392,200 lbs

9

19

3,530

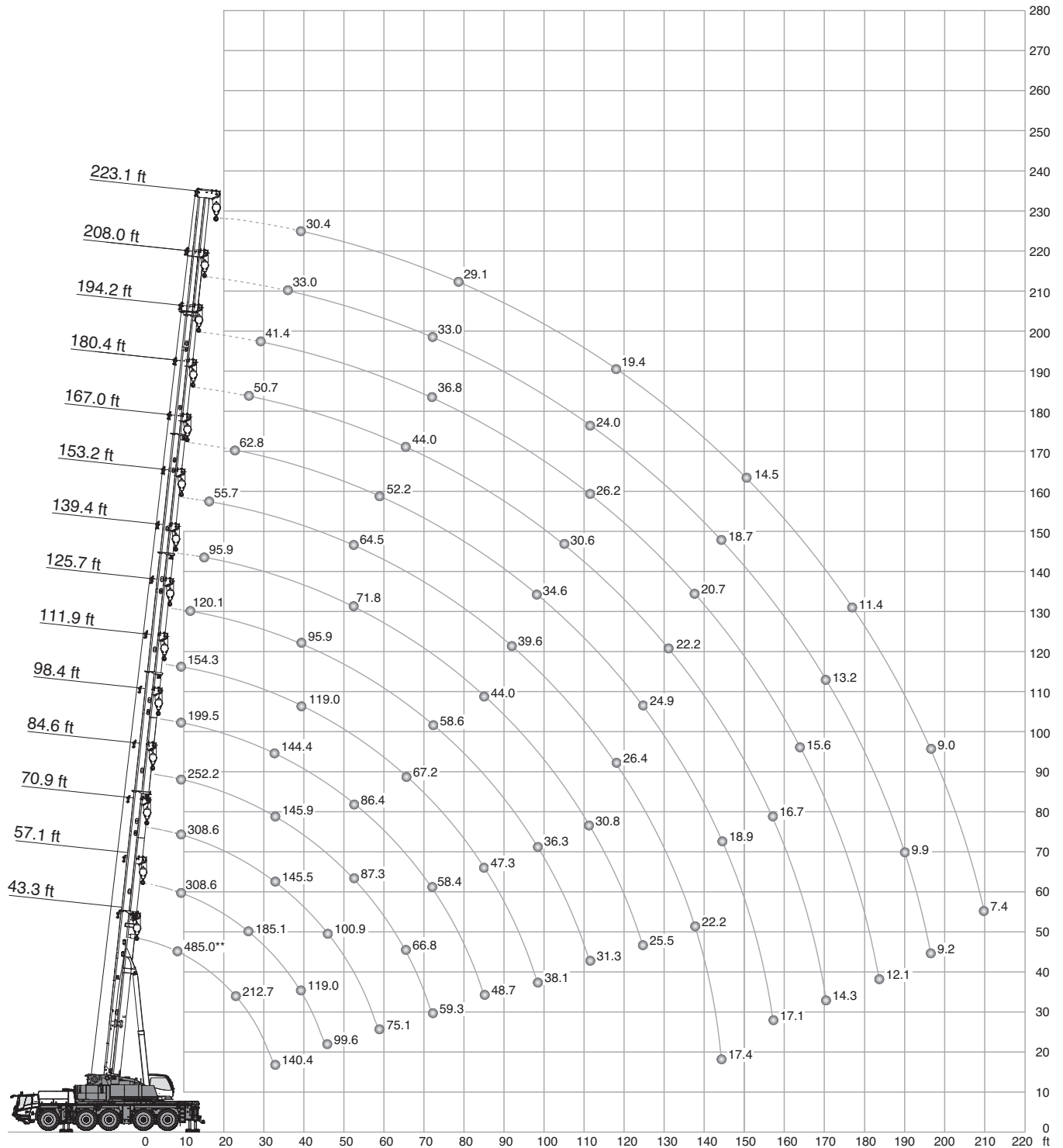

** Max. crane capacity – with additional special equipment

Operation

156,500 lbs		27.2 ft x 29.7 ft														360°		ASME B30.5	
		(ft)																	
		43.3*	43.3	57.1	70.9	84.6	98.4	111.9	125.7	139.4	153.2	167.0	180.4	194.2	208.0	223.1			
ft	1,000 lbs																ft		
8.2	485.0**	-	-	-	-	-	-	-	-	-	-	-	-	-	-	-	-	8.2	
9.8	392.2	392.2	308.6	308.6	252.2	199.5	154.3	-	-	-	-	-	-	-	-	-	-	9.8	
11.5	363.3	363.3	308.6	308.6	252.2	199.5	154.3	120.1	-	-	-	-	-	-	-	-	-	11.5	
13.1	337.0	332.0	308.6	308.6	246.4	199.5	154.3	120.1	-	-	-	-	-	-	-	-	-	13.1	
14.8	314.3	304.4	304.8	295.6	232.3	199.5	154.3	120.1	95.9	-	-	-	-	-	-	-	-	14.8	
16.4	294.0	280.4	280.8	276.6	227.0	196.4	154.3	120.1	95.9	55.7	-	-	-	-	-	-	-	16.4	
19.7	249.3	241.4	241.6	238.3	227.0	177.0	154.3	120.1	95.9	76.0	-	-	-	-	-	-	-	19.7	
23.0	212.7	210.7	210.9	210.5	208.9	170.8	147.9	120.1	95.9	76.0	62.8	-	-	-	-	-	-	23.0	
26.2	184.9	184.9	185.1	186.0	183.2	170.8	135.5	120.1	95.9	76.0	62.8	50.7	-	-	-	-	-	26.2	
29.5	162.4	162.4	162.7	163.5	161.5	162.4	127.8	117.0	95.9	76.0	62.8	50.7	41.4	-	-	-	-	29.5	
32.8	140.4	140.4	146.1	145.5	145.9	144.4	127.8	108.6	94.7	76.0	62.8	50.7	41.4	-	-	-	-	32.8	
36.1	-	-	131.3	131.8	132.0	129.4	125.8	101.4	89.9	76.0	62.8	50.7	41.4	33.0	-	-	-	36.1	
39.4	-	-	119.0	120.3	119.4	117.0	119.0	95.9	85.5	74.5	62.8	50.7	41.4	33.0	30.4	-	-	39.4	
45.9	-	-	99.6	100.9	100.0	100.9	99.6	89.2	80.0	68.1	59.5	50.7	41.4	33.0	30.4	-	-	45.9	
52.5	-	-	-	86.4	87.3	86.4	85.0	82.6	71.8	64.5	56.4	50.2	41.4	33.0	30.4	-	-	52.5	
59.1	-	-	-	75.1	75.8	75.1	73.6	75.1	65.0	59.7	52.2	46.7	41.4	33.0	30.4	-	-	59.1	
65.6	-	-	-	-	66.8	65.9	67.2	66.1	59.3	55.1	48.5	44.0	38.8	33.0	30.4	-	-	65.6	
72.2	-	-	-	-	59.3	58.4	59.9	58.6	54.4	50.7	45.1	41.2	36.8	33.0	30.4	-	-	72.2	
78.7	-	-	-	-	-	54.6	53.5	51.8	50.2	46.9	42.3	38.8	34.6	31.3	29.1	-	-	78.7	
85.3	-	-	-	-	-	48.7	47.3	45.6	44.0	43.6	39.6	36.3	32.6	29.5	27.3	-	-	85.3	
91.9	-	-	-	-	-	-	42.3	40.5	39.0	39.6	37.2	34.1	30.8	27.9	25.3	-	-	91.9	
98.4	-	-	-	-	-	-	38.1	36.3	35.9	36.3	34.6	32.4	29.1	26.6	23.5	-	-	98.4	
105.0	-	-	-	-	-	-	-	32.6	34.1	32.6	30.8	30.6	27.5	25.1	22.0	-	-	105.0	
111.5	-	-	-	-	-	-	-	31.3	30.8	29.3	27.9	28.8	26.2	24.0	20.7	-	-	111.5	
118.1	-	-	-	-	-	-	-	-	28.2	26.4	26.6	27.1	25.1	22.9	19.4	-	-	118.1	
124.7	-	-	-	-	-	-	-	-	25.5	24.4	24.9	24.4	24.0	21.8	18.2	-	-	124.7	
131.2	-	-	-	-	-	-	-	-	-	23.5	22.7	22.2	22.7	20.7	17.4	-	-	131.2	
137.8	-	-	-	-	-	-	-	-	-	22.2	20.7	20.2	20.7	19.8	16.3	-	-	137.8	
144.4	-	-	-	-	-	-	-	-	-	17.4	18.9	19.4	18.9	18.7	15.4	-	-	144.4	
150.9	-	-	-	-	-	-	-	-	-	-	18.0	18.2	17.1	17.1	14.5	-	-	150.9	
157.5	-	-	-	-	-	-	-	-	-	-	17.1	16.7	16.5	15.6	13.6	-	-	157.5	
164.0	-	-	-	-	-	-	-	-	-	-	-	15.4	15.6	14.3	13.0	-	-	164.0	
170.6	-	-	-	-	-	-	-	-	-	-	-	14.3	14.3	13.2	12.1	-	-	170.6	
177.2	-	-	-	-	-	-	-	-	-	-	-	-	13.2	11.9	11.4	-	-	177.2	
183.7	-	-	-	-	-	-	-	-	-	-	-	-	-	12.1	11.0	10.8	-	183.7	
190.3	-	-	-	-	-	-	-	-	-	-	-	-	-	-	9.9	9.9	-	190.3	
196.9	-	-	-	-	-	-	-	-	-	-	-	-	-	-	9.2	9.0	-	196.9	
203.4	-	-	-	-	-	-	-	-	-	-	-	-	-	-	-	8.1	-	203.4	
210.0	-	-	-	-	-	-	-	-	-	-	-	-	-	-	-	7.4	-	210.0	

* over rear

** Max. crane capacity – with additional special equipment

Operation

MB

103,600 lbs		27.2 ft x 29.7 ft															360°		ASME B30.5	
		(ft)																		
		43.3*	43.3	57.1	70.9	84.6	98.4	111.9	125.7	139.4	153.2	167.0	180.4	194.2	208.0	223.1				
ft	1,000 lbs																ft			
8.2	485.0	-	-	-	-	-	-	-	-	-	-	-	-	-	-	-	-	-	8.2	
9.8	392.2	384.7	308.6	308.6	252.2	199.5	154.3	-	-	-	-	-	-	-	-	-	-	-	9.8	
11.5	363.3	347.0	308.6	308.6	252.2	199.5	154.3	120.1	-	-	-	-	-	-	-	-	-	-	11.5	
13.1	337.0	315.0	308.6	308.6	246.4	199.5	154.3	120.1	-	-	-	-	-	-	-	-	-	-	13.1	
14.8	302.9	287.9	288.1	284.8	232.3	199.5	154.3	120.1	95.9	-	-	-	-	-	-	-	-	-	14.8	
16.4	272.4	264.3	264.7	261.4	227.0	196.4	154.3	120.1	95.9	55.7	-	-	-	-	-	-	-	-	16.4	
19.7	226.1	225.9	226.4	225.9	224.4	177.0	154.3	120.1	95.9	76.0	-	-	-	-	-	-	-	-	19.7	
23.0	191.5	191.5	191.8	192.6	189.8	170.8	147.9	120.1	95.9	76.0	62.8	-	-	-	-	-	-	-	23.0	
26.2	165.3	165.3	167.1	166.4	166.8	165.3	135.5	120.1	95.9	76.0	62.8	50.7	-	-	-	-	-	-	26.2	
29.5	144.8	144.8	146.8	147.0	146.3	144.8	127.8	117.0	95.9	76.0	62.8	50.7	41.4	-	-	-	-	-	29.5	
32.8	128.5	128.5	130.2	131.8	130.9	128.5	127.8	108.6	94.7	76.0	62.8	50.7	41.4	-	-	-	-	-	32.8	
36.1	-	-	117.0	118.3	117.5	118.3	113.9	101.4	89.9	76.0	62.8	50.7	41.4	33.0	-	-	-	-	36.1	
39.4	-	-	106.7	106.9	106.4	106.9	101.8	95.9	85.5	74.5	62.8	50.7	41.4	33.0	30.4	-	-	-	39.4	
45.9	-	-	87.3	87.7	88.8	87.7	85.7	83.5	78.9	68.1	59.5	50.7	41.4	33.0	30.4	-	-	-	45.9	
52.5	-	-	-	72.3	72.0	73.4	73.1	70.3	66.5	64.3	56.4	50.2	41.4	33.0	30.4	-	-	-	52.5	
59.1	-	-	-	60.1	61.2	61.9	60.8	59.0	56.8	55.1	52.2	46.7	41.4	33.0	30.4	-	-	-	59.1	
65.6	-	-	-	-	53.3	52.6	51.5	49.8	48.2	49.8	46.7	44.0	38.8	33.0	30.4	-	-	-	65.6	
72.2	-	-	-	-	46.0	45.6	44.3	43.4	44.3	42.7	40.7	41.2	36.8	33.0	30.4	-	-	-	72.2	
78.7	-	-	-	-	-	39.6	38.5	39.6	38.5	37.0	35.7	36.3	34.6	31.3	29.1	-	-	-	78.7	
85.3	-	-	-	-	-	35.0	34.8	35.4	33.7	33.9	33.0	32.8	32.6	29.5	27.3	-	-	-	85.3	
91.9	-	-	-	-	-	-	32.6	31.5	29.7	30.6	29.3	29.3	29.1	27.9	25.3	-	-	-	91.9	
98.4	-	-	-	-	-	-	29.3	28.4	27.5	27.7	27.3	26.6	26.0	25.7	23.5	-	-	-	98.4	
105.0	-	-	-	-	-	-	-	25.5	26.0	24.6	25.1	23.8	24.0	22.7	22.0	-	-	-	105.0	
111.5	-	-	-	-	-	-	-	23.3	23.8	22.2	22.7	22.4	21.3	20.2	20.0	-	-	-	111.5	
118.1	-	-	-	-	-	-	-	-	21.6	21.1	20.5	20.0	19.1	18.0	17.8	-	-	-	118.1	
124.7	-	-	-	-	-	-	-	-	19.6	19.6	19.1	18.2	17.1	16.0	15.8	-	-	-	124.7	
131.2	-	-	-	-	-	-	-	-	-	17.8	17.4	16.5	15.4	14.3	14.1	-	-	-	131.2	
137.8	-	-	-	-	-	-	-	-	-	16.3	15.8	14.7	13.8	12.7	12.5	-	-	-	137.8	
144.4	-	-	-	-	-	-	-	-	-	14.9	14.3	13.4	12.5	11.2	11.2	-	-	-	144.4	
150.9	-	-	-	-	-	-	-	-	-	-	13.2	12.1	11.2	9.9	9.9	-	-	-	150.9	
157.5	-	-	-	-	-	-	-	-	-	-	11.9	11.0	9.9	8.8	8.8	-	-	-	157.5	
164.0	-	-	-	-	-	-	-	-	-	-	-	9.9	9.0	7.7	7.7	-	-	-	164.0	
170.6	-	-	-	-	-	-	-	-	-	-	-	-	9.0	7.9	6.8	6.8	-	-	170.6	
177.2	-	-	-	-	-	-	-	-	-	-	-	-	-	7.0	5.9	5.9	-	-	177.2	
183.7	-	-	-	-	-	-	-	-	-	-	-	-	-	6.3	5.0	5.0	-	-	183.7	
190.3	-	-	-	-	-	-	-	-	-	-	-	-	-	-	4.4	4.4	-	-	190.3	
196.9	-	-	-	-	-	-	-	-	-	-	-	-	-	-	3.7	3.5	-	-	196.9	
203.4	-	-	-	-	-	-	-	-	-	-	-	-	-	-	-	3.0	-	-	203.4	
210.0	-	-	-	-	-	-	-	-	-	-	-	-	-	-	-	2.4	-	-	210.0	

* over rear

Operation

MB

77,200 lbs		27.2 ft x 29.7 ft														360°		ASME B30.5	
		(ft)																	
		43.3*	43.3	57.1	70.9	84.6	98.4	111.9	125.7	139.4	153.2	167.0	180.4	194.2	208.0	223.1			
ft	1,000 lbs																ft		
8.2	485.0	-	-	-	-	-	-	-	-	-	-	-	-	-	-	-	-	8.2	
9.8	392.2	374.7	308.6	308.6	252.2	199.5	154.3	-	-	-	-	-	-	-	-	-	-	9.8	
11.5	363.3	337.3	308.6	308.6	252.2	199.5	154.3	120.1	-	-	-	-	-	-	-	-	-	11.5	
13.1	323.4	305.5	306.0	302.6	246.4	199.5	154.3	120.1	-	-	-	-	-	-	-	-	-	13.1	
14.8	287.7	278.4	278.8	275.5	232.3	199.5	154.3	120.1	95.9	-	-	-	-	-	-	-	-	14.8	
16.4	258.8	255.2	255.7	255.0	227.0	196.4	154.3	120.1	95.9	55.7	-	-	-	-	-	-	-	16.4	
19.7	213.4	213.4	213.6	213.1	211.6	177.0	154.3	120.1	95.9	76.0	-	-	-	-	-	-	-	19.7	
23.0	180.1	180.1	182.3	181.4	181.8	170.8	147.9	120.1	95.9	76.0	62.8	-	-	-	-	-	-	23.0	
26.2	155.4	155.4	157.4	157.6	156.9	147.4	135.5	120.1	95.9	76.0	62.8	50.7	-	-	-	-	-	26.2	
29.5	136.0	136.0	138.0	139.3	136.4	131.6	123.2	115.5	95.9	76.0	62.8	50.7	41.4	-	-	-	-	29.5	
32.8	120.1	120.1	121.9	123.4	119.4	114.8	107.8	101.1	94.7	76.0	62.8	50.7	41.4	-	-	-	-	32.8	
36.1	-	-	108.9	109.3	106.9	101.4	96.5	94.3	85.9	76.0	62.8	50.7	41.4	33.0	-	-	-	36.1	
39.4	-	-	94.1	95.9	95.4	90.3	89.7	84.6	79.5	74.5	62.8	50.7	41.4	33.0	30.4	-	-	39.4	
45.9	-	-	72.7	74.5	74.5	76.7	73.8	69.4	65.2	62.8	59.5	50.7	41.4	33.0	30.4	-	-	45.9	
52.5	-	-	-	61.9	62.6	62.1	60.8	58.8	55.3	54.8	51.3	50.2	41.4	33.0	30.4	-	-	52.5	
59.1	-	-	-	51.3	52.0	51.5	50.4	49.3	50.0	46.9	43.6	44.0	41.4	33.0	30.4	-	-	59.1	
65.6	-	-	-	-	44.0	43.4	42.9	44.0	42.3	42.7	40.1	39.0	37.4	33.0	30.4	-	-	65.6	
72.2	-	-	-	-	37.9	37.2	39.0	38.1	36.1	36.8	35.9	34.8	33.9	33.0	30.4	-	-	72.2	
78.7	-	-	-	-	-	33.9	33.9	33.2	32.8	32.6	32.6	31.5	31.0	29.1	28.4	-	-	78.7	
85.3	-	-	-	-	-	30.4	29.7	29.1	29.9	28.6	28.8	28.4	27.5	25.7	25.1	-	-	85.3	
91.9	-	-	-	-	-	-	26.4	27.1	26.4	26.6	26.0	25.1	24.0	22.7	22.2	-	-	91.9	
98.4	-	-	-	-	-	-	23.5	24.2	24.0	23.5	23.1	22.2	21.1	19.8	19.8	-	-	98.4	
105.0	-	-	-	-	-	-	-	21.6	21.8	20.9	20.5	19.6	18.5	17.4	17.4	-	-	105.0	
111.5	-	-	-	-	-	-	-	19.6	19.6	18.7	18.2	17.4	16.3	15.2	15.2	-	-	111.5	
118.1	-	-	-	-	-	-	-	-	17.6	16.9	16.3	15.4	14.5	13.2	13.2	-	-	118.1	
124.7	-	-	-	-	-	-	-	-	15.8	15.2	14.7	13.6	12.7	11.6	11.4	-	-	124.7	
131.2	-	-	-	-	-	-	-	-	-	13.6	13.2	12.3	11.2	10.1	9.9	-	-	131.2	
137.8	-	-	-	-	-	-	-	-	-	12.3	11.9	10.8	9.9	8.8	8.5	-	-	137.8	
144.4	-	-	-	-	-	-	-	-	-	11.2	10.5	9.7	8.5	7.4	7.4	-	-	144.4	
150.9	-	-	-	-	-	-	-	-	-	-	9.4	8.5	7.4	6.3	6.3	-	-	150.9	
157.5	-	-	-	-	-	-	-	-	-	-	8.5	7.4	6.6	5.5	5.2	-	-	157.5	
164.0	-	-	-	-	-	-	-	-	-	-	-	6.6	5.7	4.4	4.4	-	-	164.0	
170.6	-	-	-	-	-	-	-	-	-	-	-	5.9	4.8	3.7	3.5	-	-	170.6	
177.2	-	-	-	-	-	-	-	-	-	-	-	-	4.1	2.8	2.8	-	-	177.2	
183.7	-	-	-	-	-	-	-	-	-	-	-	-	3.5	2.2	-	-	-	183.7	
190.3	-	-	-	-	-	-	-	-	-	-	-	-	-	1.5	-	-	-	190.3	
196.9	-	-	-	-	-	-	-	-	-	-	-	-	-	-	1.1	-	-	196.9	

* over rear

Operation

MB

51,800 lbs		27.2 ft x 29.7 ft																360°	ASME B30.5
		(ft)																	
		43.3*	43.3	57.1	70.9	84.6	98.4	111.9	125.7	139.4	153.2	167.0	180.4	194.2	208.0	223.1			
ft	1,000 lbs																ft		
8.2	478.8	-	-	-	-	-	-	-	-	-	-	-	-	-	-	-	-	8.2	
9.8	392.2	364.4	308.6	308.6	252.2	199.5	154.3	-	-	-	-	-	-	-	-	-	-	9.8	
11.5	349.6	326.9	308.6	308.6	252.2	199.5	154.3	120.1	-	-	-	-	-	-	-	-	-	11.5	
13.1	306.8	295.4	295.8	292.5	246.4	199.5	154.3	120.1	-	-	-	-	-	-	-	-	-	13.1	
14.8	272.9	268.7	269.1	265.6	232.3	199.5	154.3	120.1	95.9	-	-	-	-	-	-	-	-	14.8	
16.4	244.4	244.4	244.7	244.2	227.0	196.4	154.3	120.1	95.9	55.7	-	-	-	-	-	-	-	16.4	
19.7	200.6	200.6	202.6	201.9	189.5	172.8	154.3	120.1	95.9	76.0	-	-	-	-	-	-	-	19.7	
23.0	169.3	169.3	171.2	169.9	157.6	145.0	133.8	120.1	95.9	76.0	62.8	-	-	-	-	-	-	23.0	
26.2	145.2	145.2	147.4	141.7	135.3	126.5	117.7	109.3	95.9	76.0	62.8	50.7	-	-	-	-	-	26.2	
29.5	122.7	122.7	126.5	119.7	115.3	108.2	105.1	95.9	89.5	76.0	62.8	50.7	41.4	-	-	-	-	29.5	
32.8	100.9	100.9	105.6	104.7	99.8	97.2	92.8	86.8	81.1	76.0	62.8	50.7	41.4	-	-	-	-	32.8	
36.1	-	-	89.2	91.0	88.4	86.8	82.0	77.6	71.8	68.7	62.8	50.7	41.4	33.0	-	-	-	36.1	
39.4	-	-	76.7	78.4	80.9	77.3	73.1	69.4	65.9	61.2	59.7	50.7	41.4	33.0	30.4	-	-	39.4	
45.9	-	-	59.7	62.3	63.0	62.6	59.7	57.3	55.9	53.3	48.7	48.0	41.4	33.0	30.4	-	-	45.9	
52.5	-	-	-	50.0	50.7	50.2	49.8	50.2	46.7	46.0	44.7	42.3	39.9	33.0	30.4	-	-	52.5	
59.1	-	-	-	41.2	41.8	41.8	43.2	42.5	41.8	40.3	39.2	37.2	35.0	33.0	30.4	-	-	59.1	
65.6	-	-	-	-	35.0	37.0	36.3	35.7	36.5	35.7	34.6	33.2	31.3	29.1	28.2	-	-	65.6	
72.2	-	-	-	-	31.5	31.5	31.0	31.9	31.5	31.3	30.6	28.8	27.1	24.9	24.2	-	-	72.2	
78.7	-	-	-	-	-	27.3	28.2	27.5	27.7	27.1	26.6	25.1	23.5	21.6	20.9	-	-	78.7	
85.3	-	-	-	-	-	23.8	24.4	24.2	24.2	23.3	22.9	22.0	20.5	18.5	18.0	-	-	85.3	
91.9	-	-	-	-	-	-	21.6	21.1	21.1	20.2	19.8	18.9	17.8	16.0	15.6	-	-	91.9	
98.4	-	-	-	-	-	-	18.9	18.7	18.5	17.8	17.4	16.3	15.4	13.8	13.4	-	-	98.4	
105.0	-	-	-	-	-	-	-	16.5	16.3	15.6	15.2	14.1	13.2	11.9	11.6	-	-	105.0	
111.5	-	-	-	-	-	-	-	14.7	14.5	13.6	13.2	12.3	11.2	9.9	9.9	-	-	111.5	
118.1	-	-	-	-	-	-	-	-	12.7	12.1	11.6	10.5	9.7	8.3	8.3	-	-	118.1	
124.7	-	-	-	-	-	-	-	-	11.4	10.5	10.1	9.2	8.1	6.8	6.8	-	-	124.7	
131.2	-	-	-	-	-	-	-	-	-	9.4	8.8	7.9	6.8	5.7	5.5	-	-	131.2	
137.8	-	-	-	-	-	-	-	-	-	8.3	7.7	6.8	5.7	4.4	4.4	-	-	137.8	
144.4	-	-	-	-	-	-	-	-	-	7.2	6.6	5.7	4.6	-	-	-	-	144.4	
150.9	-	-	-	-	-	-	-	-	-	-	5.7	4.8	3.7	-	-	-	-	150.9	
157.5	-	-	-	-	-	-	-	-	-	-	4.8	3.9	2.8	-	-	-	-	157.5	
164.0	-	-	-	-	-	-	-	-	-	-	-	3.0	2.2	-	-	-	-	164.0	
170.6	-	-	-	-	-	-	-	-	-	-	-	-	2.6	-	-	-	-	170.6	

* over rear

Operation

26,500 lbs		27.2 ft x 29.7 ft														360°		ASME B30.5	
		(ft)																	
		43.3*	43.3	57.1	70.9	84.6	98.4	111.9	125.7	139.4	153.2	167.0	180.4	194.2	208.0	223.1			
ft	1,000 lbs															ft			
8.2	455.9	-	-	-	-	-	-	-	-	-	-	-	-	-	-	-	-	8.2	
9.8	384.2	353.1	308.6	308.6	252.2	199.5	154.3	-	-	-	-	-	-	-	-	-	-	9.8	
11.5	331.3	315.9	308.6	308.6	252.2	199.5	154.3	120.1	-	-	-	-	-	-	-	-	-	11.5	
13.1	290.5	284.6	285.0	281.5	246.4	199.5	154.3	120.1	-	-	-	-	-	-	-	-	-	13.1	
14.8	256.6	256.6	257.0	256.6	227.0	199.5	154.3	120.1	95.9	-	-	-	-	-	-	-	-	14.8	
16.4	229.0	229.0	229.5	223.1	197.9	176.8	154.3	120.1	95.9	55.7	-	-	-	-	-	-	-	16.4	
19.7	187.8	187.8	186.0	170.8	156.0	141.5	128.9	120.1	95.9	76.0	-	-	-	-	-	-	-	19.7	
23.0	154.5	154.5	144.6	137.1	129.6	120.1	112.4	101.4	95.4	76.0	62.8	-	-	-	-	-	-	23.0	
26.2	121.6	121.6	119.2	113.9	107.1	104.4	97.6	90.3	82.8	76.0	62.8	50.7	-	-	-	-	-	26.2	
29.5	95.9	95.9	99.6	95.9	94.3	89.2	83.7	78.4	71.8	68.1	62.8	50.7	41.4	-	-	-	-	29.5	
32.8	78.0	78.0	82.8	84.8	81.5	77.6	73.6	70.7	66.8	59.7	57.3	50.7	41.4	-	-	-	-	32.8	
36.1	-	-	70.7	73.6	71.6	68.1	64.8	64.3	59.0	55.7	50.0	48.9	41.4	33.0	-	-	-	36.1	
39.4	-	-	60.4	63.0	63.4	60.4	60.1	57.3	55.1	51.5	47.6	44.0	41.4	33.0	30.4	-	-	39.4	
45.9	-	-	45.6	48.2	48.9	50.4	48.5	46.0	45.6	44.5	41.6	38.1	35.7	33.0	30.4	-	-	45.9	
52.5	-	-	-	38.1	40.3	40.5	39.9	39.9	38.8	36.8	35.0	33.0	30.8	28.2	27.3	-	-	52.5	
59.1	-	-	-	30.6	32.6	32.8	33.9	33.7	32.8	31.0	29.5	27.5	25.5	23.3	22.7	-	-	59.1	
65.6	-	-	-	-	26.8	27.5	28.2	27.7	27.7	26.4	25.1	23.3	21.3	19.4	18.7	-	-	65.6	
72.2	-	-	-	-	22.4	22.9	23.5	23.3	23.3	22.4	21.3	19.8	18.0	16.0	15.6	-	-	72.2	
78.7	-	-	-	-	-	19.6	20.0	19.8	19.6	18.9	18.5	16.7	15.2	13.4	13.0	-	-	78.7	
85.3	-	-	-	-	-	16.7	17.1	16.7	16.7	16.0	15.6	14.3	12.7	11.0	10.5	-	-	85.3	
91.9	-	-	-	-	-	-	14.7	14.5	14.3	13.6	13.2	12.1	10.8	9.0	8.5	-	-	91.9	
98.4	-	-	-	-	-	-	12.7	12.3	12.3	11.4	11.0	10.1	9.0	7.2	7.0	-	-	98.4	
105.0	-	-	-	-	-	-	-	10.8	10.5	9.9	9.2	8.3	7.2	-	-	-	-	105.0	
111.5	-	-	-	-	-	-	-	9.2	9.0	8.3	7.7	6.8	5.9	-	-	-	-	111.5	
118.1	-	-	-	-	-	-	-	-	7.7	7.0	6.3	5.5	-	-	-	-	-	118.1	
124.7	-	-	-	-	-	-	-	-	6.6	5.9	5.2	4.4	-	-	-	-	-	124.7	
131.2	-	-	-	-	-	-	-	-	-	4.8	4.4	3.3	-	-	-	-	-	131.2	
137.8	-	-	-	-	-	-	-	-	-	3.9	3.3	-	-	-	-	-	-	137.8	
144.4	-	-	-	-	-	-	-	-	-	3.3	2.6	-	-	-	-	-	-	144.4	
150.9	-	-	-	-	-	-	-	-	-	-	1.9	-	-	-	-	-	-	150.9	
157.5	-	-	-	-	-	-	-	-	-	-	1.3	-	-	-	-	-	-	157.5	

0 lbs		27.2 ft x 29.7 ft														360°		ASME B30.5	
		(ft)																	
		43.3*	43.3	57.1	70.9	84.6	98.4	111.9	125.7	139.4	153.2	167.0	180.4	194.2	208.0	223.1			
ft	1,000 lbs															ft			
8.2	430.5	-	-	-	-	-	-	-	-	-	-	-	-	-	-	-	-	8.2	
9.8	362.8	340.8	308.6	308.6	252.2	199.5	154.3	-	-	-	-	-	-	-	-	-	-	9.8	
11.5	312.6	303.7	304.2	300.9	252.2	199.5	154.3	120.1	-	-	-	-	-	-	-	-	-	11.5	
13.1	271.8	271.8	272.4	250.0	212.5	183.4	154.3	120.1	-	-	-	-	-	-	-	-	-	13.1	
14.8	239.6	239.6	231.0	207.2	182.3	159.8	141.3	120.1	95.9	-	-	-	-	-	-	-	-	14.8	
16.4	213.6	213.6	192.2	172.4	153.8	136.2	127.8	115.5	95.9	55.7	-	-	-	-	-	-	-	16.4	
19.7	149.9	149.9	141.3	131.6	121.2	116.1	106.4	95.9	83.7	76.0	-	-	-	-	-	-	-	19.7	
23.0	113.3	113.3	108.9	104.2	100.3	93.4	87.3	79.1	70.3	65.2	62.1	-	-	-	-	-	-	23.0	
26.2	88.6	88.6	89.2	86.8	82.4	76.7	74.9	69.2	62.8	57.0	51.3	49.6	-	-	-	-	-	26.2	
29.5	68.7	68.7	72.5	71.4	68.3	67.2	63.2	59.3	56.6	51.8	47.1	42.9	41.4	-	-	-	-	29.5	
32.8	55.1	53.7	60.4	59.9	58.8	57.5	54.6	53.3	50.9	47.1	42.1	39.0	36.3	-	-	-	-	32.8	
36.1	-	-	49.1	51.1	51.8	49.8	48.9	46.5	44.5	41.8	39.4	36.8	33.0	30.8	-	-	-	36.1	
39.4	-	-	40.7	44.3	45.1	44.0	42.9	41.0	39.4	37.0	34.8	32.4	29.7	26.8	25.7	-	-	39.4	
45.9	-	-	29.1	32.4	34.6	34.6	34.1	32.6	31.3	29.3	27.5	25.5	23.3	20.9	20.0	-	-	45.9	
52.5	-	-	-	24.4	26.6	27.3	27.5	26.4	25.3	23.8	22.2	20.2	18.2	16.3	15.4	-	-	52.5	
59.1	-	-	-	18.7	20.9	21.6	22.2	21.8	20.9	19.4	18.0	16.3	14.5	12.5	11.9	-	-	59.1	
65.6	-	-	-	-	16.7	17.1	17.8	17.6	17.4	16.0	14.7	13.2	11.4	9.7	9.0	-	-	65.6	
72.2	-	-	-	-	13.4	13.8	14.5	14.3	14.1	13.2	12.1	10.5	9.0	7.2	-	-	-	72.2	
78.7	-	-	-	-	-	11.2	11.9	11.4	11.4	10.8	9.9	8.3	6.8	-	-	-	-	78.7	
85.3	-	-	-	-	-	9.2	9.7	9.4	9.2	8.5	7.9	6.6	-	-	-	-	-	85.3	
91.9	-	-	-	-	-	-	7.9	7.7	7.4	6.8	6.3	5.0	-	-	-	-	-	91.9	
98.4	-	-	-	-	-	-	6.3	6.1	5.9	5.2	4.8	-	-	-	-	-	-	98.4	
105.0	-	-	-	-	-	-	-	4.8	4.6	3.9	3.5	-	-	-	-	-	-	105.0	
111.5	-	-	-	-	-	-	-	3.7	3.5	2.8	-	-	-	-	-	-	-	111.5	
118.1	-	-	-	-	-	-	-	-	2.6	-	-	-	-	-	-	-	-	118.1	
124.7	-	-	-	-	-	-	-	-	1.7	-	-	-	-	-	-	-	-	124.7	

* over rear

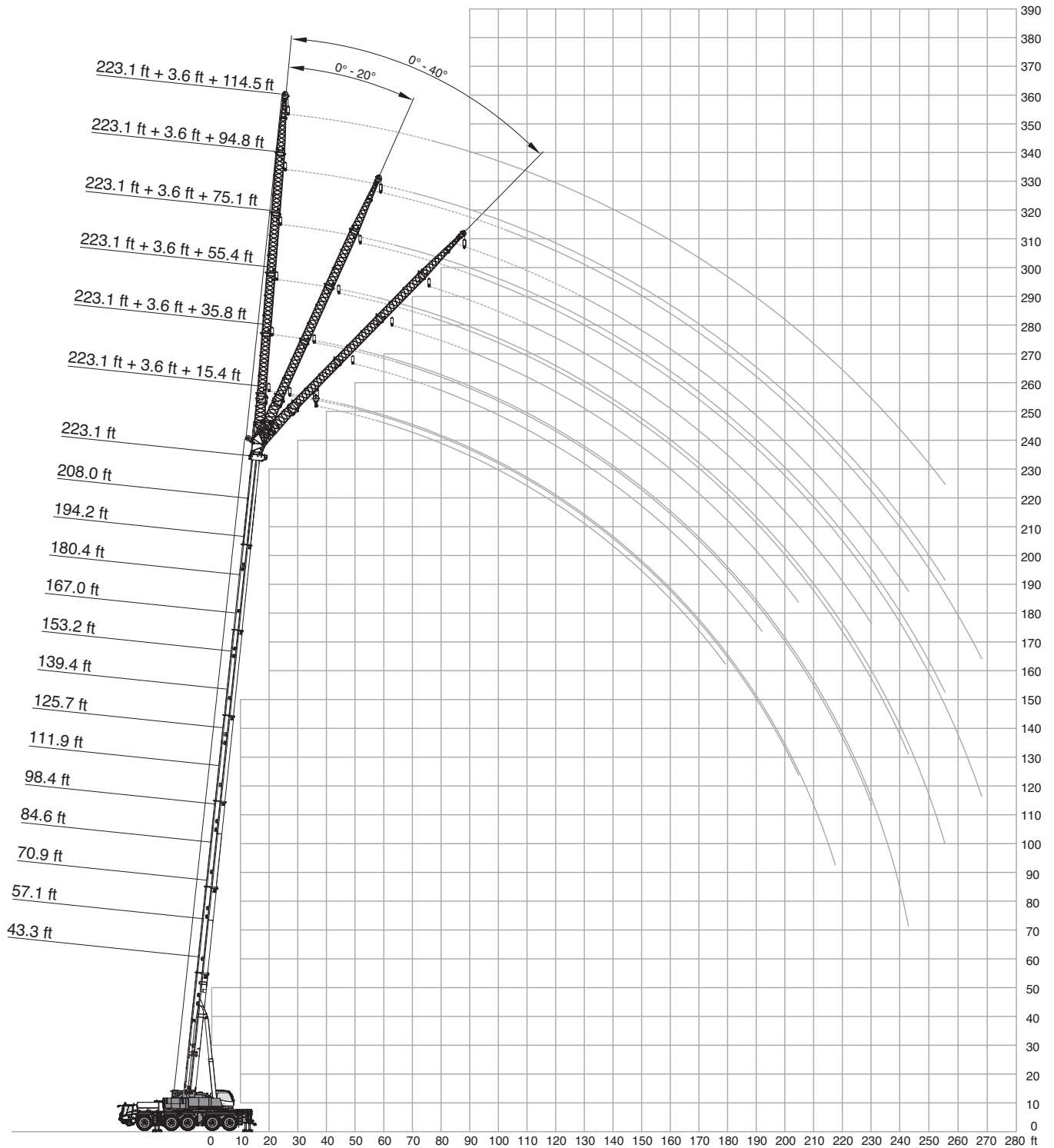

Operation



156,500 lbs			27.2 ft x 29.7 ft			3.6 ft + 15.4 ft			360°			ASME B30.5		
43.3 ft		98.4 ft			139.4 ft			180.4 ft			223.1 ft			
0°	20°	40°	0°	20°	40°	0°	20°	40°	0°	20°	40°	0°	20°	40°
1,000 lbs														
ft														ft
9.8	101.4	-	-	-	-	-	-	-	-	-	-	-	-	9.8
11.5	96.1	68.1	-	-	-	-	-	-	-	-	-	-	-	11.5
13.1	91.4	65.9	-	-	-	-	-	-	-	-	-	-	-	13.1
14.8	87.3	63.7	51.5	74.7	-	-	-	-	-	-	-	-	-	14.8
16.4	83.3	61.9	50.4	94.5	-	-	-	-	-	-	-	-	-	16.4
19.7	76.7	58.4	48.5	94.5	-	-	-	-	-	-	-	-	-	19.7
23.0	70.9	55.3	46.7	94.5	64.3	-	47.6	-	-	-	-	-	-	23.0
26.2	66.1	52.9	45.4	90.3	62.3	49.8	52.9	-	-	-	-	-	-	26.2
29.5	62.1	50.4	44.0	85.9	60.4	48.7	52.9	52.9	-	-	-	-	-	29.5
32.8	58.6	48.7	42.9	82.2	58.6	47.8	52.9	52.9	43.4	29.1	-	-	-	32.8
36.1	55.5	46.9	42.3	78.4	56.8	46.9	52.9	52.9	48.0	34.1	-	-	-	36.1
39.4	52.6	45.4	41.8	75.3	55.5	46.2	52.9	52.9	47.3	34.1	34.1	-	-	39.4
45.9	45.6	41.4	-	69.6	52.6	44.7	52.9	52.9	46.0	34.1	34.1	34.1	22.0	45.9
52.5	40.1	-	-	64.8	50.4	43.6	52.9	52.9	45.1	34.1	34.1	34.1	22.0	52.5
59.1	-	-	-	60.8	48.5	42.7	52.2	50.7	44.3	34.1	34.1	34.1	22.0	59.1
65.6	-	-	-	57.3	46.7	41.8	48.7	48.0	43.4	34.1	34.1	34.1	22.0	65.6
72.2	-	-	-	53.1	45.1	41.4	46.9	45.8	42.7	32.8	32.4	32.4	22.0	72.2
78.7	-	-	-	50.4	44.0	40.7	44.0	43.2	42.1	30.8	30.6	31.5	22.0	78.7
85.3	-	-	-	47.1	42.3	40.3	41.4	40.5	40.3	29.3	29.9	29.9	22.0	85.3
91.9	-	-	-	41.8	40.7	-	37.9	38.3	38.1	28.4	28.2	28.2	21.1	91.9
98.4	-	-	-	37.6	37.9	-	33.5	34.3	34.8	26.8	26.6	26.6	20.2	98.4
105.0	-	-	-	32.8	-	-	30.4	30.4	30.8	25.5	25.3	25.3	19.4	105.0
111.5	-	-	-	-	-	-	28.8	28.4	28.4	24.2	24.0	24.0	18.7	111.5
118.1	-	-	-	-	-	-	26.4	27.1	27.1	22.9	22.9	22.9	17.4	118.1
124.7	-	-	-	-	-	-	24.0	24.4	-	21.8	21.8	21.8	16.3	124.7
131.2	-	-	-	-	-	-	21.8	22.0	-	20.7	20.7	20.7	15.4	131.2
137.8	-	-	-	-	-	-	19.8	20.0	-	18.7	19.1	19.4	14.3	137.8
144.4	-	-	-	-	-	-	18.5	18.2	-	16.9	17.4	17.4	13.6	144.4
150.9	-	-	-	-	-	-	-	-	-	16.0	16.0	-	12.7	150.9
157.5	-	-	-	-	-	-	-	-	-	15.2	15.2	-	12.1	157.5
164.0	-	-	-	-	-	-	-	-	-	14.3	14.5	-	11.4	164.0
170.6	-	-	-	-	-	-	-	-	-	13.0	13.2	-	10.8	170.6
183.7	-	-	-	-	-	-	-	-	-	11.4	-	-	9.4	183.7
196.9	-	-	-	-	-	-	-	-	-	-	-	-	8.3	196.9
210.0	-	-	-	-	-	-	-	-	-	-	-	-	6.8	210.0
223.1	-	-	-	-	-	-	-	-	-	-	-	-	5.5	223.1

Operation



103,600 lbs			27.2 ft x 29.7 ft			3.6 ft + 15.4 ft			360°			ASME B30.5					
43.3 ft			98.4 ft			139.4 ft			180.4 ft			223.1 ft					
0°			20°			40°			0°			20°			40°		
ft	1,000 lbs															ft	
9.8	101.4	-	-	-	-	-	-	-	-	-	-	-	-	-	-	-	9.8
11.5	96.1	68.1	-	-	-	-	-	-	-	-	-	-	-	-	-	-	11.5
13.1	91.4	65.9	-	-	-	-	-	-	-	-	-	-	-	-	-	-	13.1
14.8	87.3	63.7	51.5	74.7	-	-	-	-	-	-	-	-	-	-	-	-	14.8
16.4	83.3	61.9	50.4	94.5	-	-	-	-	-	-	-	-	-	-	-	-	16.4
19.7	76.7	58.4	48.5	94.5	-	-	-	-	-	-	-	-	-	-	-	-	19.7
23.0	70.9	55.3	46.7	94.5	64.3	-	47.6	-	-	-	-	-	-	-	-	-	23.0
26.2	66.1	52.9	45.4	90.3	62.3	49.8	52.9	-	-	-	-	-	-	-	-	-	26.2
29.5	62.1	50.4	44.0	85.9	60.4	48.7	52.9	52.9	-	-	-	-	-	-	-	-	29.5
32.8	58.6	48.7	42.9	82.2	58.6	47.8	52.9	52.9	43.4	29.1	-	-	-	-	-	-	32.8
36.1	55.5	46.9	42.3	78.4	56.8	46.9	52.9	52.9	48.0	34.1	-	-	-	-	-	-	36.1
39.4	52.6	45.4	41.8	75.3	55.5	46.2	52.9	52.9	47.3	34.1	34.1	-	-	-	-	-	39.4
45.9	45.6	41.4	-	69.6	52.6	44.7	52.9	52.9	46.0	34.1	34.1	34.1	22.0	-	-	-	45.9
52.5	40.1	-	-	64.8	50.4	43.6	52.9	52.9	45.1	34.1	34.1	34.1	22.0	22.0	-	-	52.5
59.1	-	-	-	59.9	48.5	42.7	52.2	50.7	44.3	34.1	34.1	34.1	22.0	22.0	22.0	-	59.1
65.6	-	-	-	51.3	46.7	41.8	46.2	47.6	43.4	34.1	34.1	34.1	22.0	22.0	22.0	-	65.6
72.2	-	-	-	44.0	45.1	41.4	41.0	41.2	42.1	32.8	32.4	32.4	22.0	22.0	22.0	-	72.2
78.7	-	-	-	38.3	39.0	39.4	37.0	36.1	35.9	30.8	30.6	31.5	22.0	22.0	22.0	-	78.7
85.3	-	-	-	33.5	34.1	34.3	32.1	33.2	32.6	29.3	29.9	29.9	22.0	21.6	21.1	-	85.3
91.9	-	-	-	31.3	29.9	-	29.1	29.1	29.5	27.1	27.9	28.2	21.1	20.7	20.5	-	91.9
98.4	-	-	-	28.6	28.6	-	25.7	26.4	26.8	23.8	24.4	25.1	20.2	20.0	19.8	-	98.4
105.0	-	-	-	25.7	-	-	23.8	23.5	23.8	22.7	23.1	23.1	19.4	19.1	19.6	-	105.0
111.5	-	-	-	-	-	-	21.6	22.0	22.0	20.0	20.7	21.1	18.7	18.5	18.7	-	111.5
118.1	-	-	-	-	-	-	19.8	19.8	19.8	18.9	18.9	19.1	17.4	17.4	17.4	-	118.1
124.7	-	-	-	-	-	-	18.7	18.7	-	17.6	18.0	18.0	15.6	16.3	16.5	-	124.7
131.2	-	-	-	-	-	-	16.9	17.1	-	15.8	16.3	16.5	13.8	14.3	14.7	-	131.2
137.8	-	-	-	-	-	-	15.2	15.4	-	14.3	14.5	14.7	12.3	12.7	13.0	-	137.8
144.4	-	-	-	-	-	-	14.5	14.5	-	12.7	13.2	13.2	10.8	11.2	11.6	-	144.4
150.9	-	-	-	-	-	-	-	-	-	11.6	11.9	-	9.7	9.9	10.1	-	150.9
157.5	-	-	-	-	-	-	-	-	-	10.3	10.5	-	8.3	8.8	9.0	-	157.5
164.0	-	-	-	-	-	-	-	-	-	9.2	9.4	-	7.2	7.7	7.9	-	164.0
170.6	-	-	-	-	-	-	-	-	-	8.3	8.5	-	6.3	6.6	6.8	-	170.6
183.7	-	-	-	-	-	-	-	-	-	6.6	-	-	4.6	4.8	4.8	-	183.7
196.9	-	-	-	-	-	-	-	-	-	-	-	-	3.0	3.3	-	-	196.9

Operation

156,500 lbs			27.2 ft x 29.7 ft			3.6 ft + 35.8 ft			360°			ASME B30.5		
43.3 ft		98.4 ft			139.4 ft			180.4 ft			223.1 ft			
0°	20°	40°	0°	20°	40°	0°	20°	40°	0°	20°	40°	0°	20°	40°
1,000 lbs														
ft														ft
9.8	43.4	-	-	-	-	-	-	-	-	-	-	-	-	9.8
11.5	43.2	-	-	-	-	-	-	-	-	-	-	-	-	11.5
13.1	42.1	-	-	-	-	-	-	-	-	-	-	-	-	13.1
14.8	41.0	-	-	-	-	-	-	-	-	-	-	-	-	14.8
16.4	39.6	-	-	-	-	-	-	-	-	-	-	-	-	16.4
19.7	37.4	31.0	-	42.1	-	-	-	-	-	-	-	-	-	19.7
23.0	35.2	29.1	-	40.7	-	-	-	-	-	-	-	-	-	23.0
26.2	33.2	27.3	-	39.2	-	-	-	-	-	-	-	-	-	26.2
29.5	31.5	25.5	-	37.9	-	-	35.2	-	-	-	-	-	-	29.5
32.8	29.7	24.2	20.5	36.3	28.8	-	34.6	-	-	-	-	-	-	32.8
36.1	28.4	23.1	19.6	35.2	27.7	-	33.7	-	-	-	-	-	-	36.1
39.4	27.1	22.0	18.9	33.9	26.6	-	32.8	-	-	22.0	-	-	-	39.4
45.9	24.2	20.0	17.8	31.7	24.9	20.0	31.5	25.7	-	22.0	-	-	-	45.9
52.5	21.6	18.5	16.9	29.7	23.3	19.1	29.9	24.6	20.0	22.0	22.0	-	14.5	52.5
59.1	19.4	17.4	16.3	27.9	22.0	18.5	28.6	23.5	19.4	22.0	22.0	-	14.5	59.1
65.6	17.6	16.5	-	26.4	20.9	17.8	27.3	22.4	18.7	22.0	21.3	18.9	14.5	65.6
72.2	16.3	15.8	-	25.1	19.8	17.4	26.2	21.6	18.2	22.0	20.9	18.5	14.5	72.2
78.7	-	-	-	23.5	18.9	16.9	25.3	20.7	17.8	22.0	20.2	18.0	14.5	78.7
85.3	-	-	-	22.0	18.2	16.5	24.2	20.0	17.4	22.0	19.8	17.8	14.5	85.3
91.9	-	-	-	20.7	17.6	16.3	23.3	19.4	17.1	22.0	19.4	17.4	14.5	91.9
98.4	-	-	-	19.6	16.9	16.0	22.7	18.7	16.7	21.6	18.9	17.1	14.5	98.4
105.0	-	-	-	18.5	16.5	15.8	21.8	18.0	16.5	21.1	18.5	16.9	14.5	105.0
111.5	-	-	-	17.6	16.0	-	20.9	17.6	16.3	20.5	18.0	16.7	14.5	111.5
118.1	-	-	-	16.7	15.8	-	20.0	17.1	16.0	20.0	17.6	16.5	14.5	118.1
124.7	-	-	-	16.3	-	-	19.1	16.9	16.0	19.6	17.4	16.3	14.5	124.7
131.2	-	-	-	-	-	-	18.5	16.5	15.8	18.7	16.9	16.0	14.3	131.2
137.8	-	-	-	-	-	-	17.8	16.3	15.8	17.8	16.7	15.8	13.4	137.8
144.4	-	-	-	-	-	-	17.1	16.0	-	17.1	16.3	15.8	12.5	144.4
150.9	-	-	-	-	-	-	16.7	15.8	-	16.3	16.0	15.6	11.9	150.9
157.5	-	-	-	-	-	-	16.3	15.8	-	14.9	15.6	15.6	11.2	157.5
164.0	-	-	-	-	-	-	14.9	-	-	13.6	14.3	14.7	10.5	164.0
170.6	-	-	-	-	-	-	-	-	-	12.7	13.0	-	9.9	170.6
183.7	-	-	-	-	-	-	-	-	-	11.6	11.6	-	8.8	183.7
196.9	-	-	-	-	-	-	-	-	-	9.9	10.3	-	7.9	196.9
210.0	-	-	-	-	-	-	-	-	-	8.8	-	-	7.0	210.0
223.1	-	-	-	-	-	-	-	-	-	-	-	-	5.9	223.1
236.2	-	-	-	-	-	-	-	-	-	-	-	-	4.8	236.2
249.3	-	-	-	-	-	-	-	-	-	-	-	-	3.7	249.3

Operation



103,600 lbs			27.2 ft x 29.7 ft			3.6 ft + 35.8 ft			360°			ASME B30.5					
43.3 ft		98.4 ft			139.4 ft			180.4 ft			223.1 ft						
0°		20°		40°		0°		20°		40°		0°		20°		40°	
ft	1,000 lbs																ft
9.8	43.4	-	-	-	-	-	-	-	-	-	-	-	-	-	-	-	9.8
11.5	43.2	-	-	-	-	-	-	-	-	-	-	-	-	-	-	-	11.5
13.1	42.1	-	-	-	-	-	-	-	-	-	-	-	-	-	-	-	13.1
14.8	41.0	-	-	-	-	-	-	-	-	-	-	-	-	-	-	-	14.8
16.4	39.6	-	-	-	-	-	-	-	-	-	-	-	-	-	-	-	16.4
19.7	37.4	31.0	-	42.1	-	-	-	-	-	-	-	-	-	-	-	-	19.7
23.0	35.2	29.1	-	40.7	-	-	-	-	-	-	-	-	-	-	-	-	23.0
26.2	33.2	27.3	-	39.2	-	-	-	-	-	-	-	-	-	-	-	-	26.2
29.5	31.5	25.5	-	37.9	-	-	35.2	-	-	-	-	-	-	-	-	-	29.5
32.8	29.7	24.2	20.5	36.3	28.8	-	34.6	-	-	-	-	-	-	-	-	-	32.8
36.1	28.4	23.1	19.6	35.2	27.7	-	33.7	-	-	-	-	-	-	-	-	-	36.1
39.4	27.1	22.0	18.9	33.9	26.6	-	32.8	-	-	22.0	-	-	-	-	-	-	39.4
45.9	24.2	20.0	17.8	31.7	24.9	20.0	31.5	25.7	-	22.0	-	-	-	-	-	-	45.9
52.5	21.6	18.5	16.9	29.7	23.3	19.1	29.9	24.6	20.0	22.0	22.0	-	14.5	-	-	-	52.5
59.1	19.4	17.4	16.3	27.9	22.0	18.5	28.6	23.5	19.4	22.0	22.0	-	14.5	-	-	-	59.1
65.6	17.6	16.5	-	26.4	20.9	17.8	27.3	22.4	18.7	22.0	21.3	18.9	14.5	14.5	-	-	65.6
72.2	16.3	15.8	-	25.1	19.8	17.4	26.2	21.6	18.2	22.0	20.9	18.5	14.5	14.5	-	-	72.2
78.7	-	-	-	23.5	18.9	16.9	25.3	20.7	17.8	22.0	20.2	18.0	14.5	14.5	14.5	-	78.7
85.3	-	-	-	22.0	18.2	16.5	24.2	20.0	17.4	22.0	19.8	17.8	14.5	14.5	14.5	-	85.3
91.9	-	-	-	20.7	17.6	16.3	23.3	19.4	17.1	22.0	19.4	17.4	14.5	14.5	14.5	-	91.9
98.4	-	-	-	19.6	16.9	16.0	22.7	18.7	16.7	21.6	18.9	17.1	14.5	14.5	14.5	-	98.4
105.0	-	-	-	18.5	16.5	15.8	21.3	18.0	16.5	21.1	18.5	16.9	14.5	14.5	14.5	-	105.0
111.5	-	-	-	17.6	16.0	-	20.5	17.6	16.3	19.4	18.0	16.7	14.5	14.5	14.5	-	111.5
118.1	-	-	-	16.7	15.8	-	19.4	17.1	16.0	18.0	17.6	16.5	14.5	14.3	14.3	-	118.1
124.7	-	-	-	16.0	-	-	18.5	16.7	16.0	16.9	16.9	16.3	14.5	14.3	13.8	-	124.7
131.2	-	-	-	-	-	-	16.7	16.3	15.8	15.2	16.3	15.8	14.3	13.8	13.4	-	131.2
137.8	-	-	-	-	-	-	15.6	15.8	15.8	14.7	14.5	15.4	12.7	13.2	13.0	-	137.8
144.4	-	-	-	-	-	-	14.7	14.7	-	13.6	13.4	13.6	11.2	12.3	12.3	-	144.4
150.9	-	-	-	-	-	-	13.4	13.8	-	12.3	13.0	12.7	10.1	11.0	11.9	-	150.9
157.5	-	-	-	-	-	-	12.3	12.7	-	11.2	11.9	12.3	8.8	9.9	10.5	-	157.5
164.0	-	-	-	-	-	-	11.9	-	-	10.1	10.8	11.2	7.7	8.5	9.2	-	164.0
170.6	-	-	-	-	-	-	-	-	-	9.2	9.7	-	6.8	7.7	8.1	-	170.6
183.7	-	-	-	-	-	-	-	-	-	7.4	7.9	-	5.0	5.7	6.1	-	183.7
196.9	-	-	-	-	-	-	-	-	-	5.9	6.3	-	3.5	4.1	4.6	-	196.9
210.0	-	-	-	-	-	-	-	-	-	4.8	-	-	-	2.8	-	-	210.0

Operation

156,500 lbs			27.2 ft x 29.7 ft			3.6 ft + 55.4 ft			360°			ASME B30.5					
43.3 ft		98.4 ft			139.4 ft			180.4 ft			223.1 ft						
0°		20°		40°		0°		20°		40°		0°		20°		40°	
1,000 lbs																	
ft																	ft
9.8	38.8	-	-	-	-	-	-	-	-	-	-	-	-	-	-	-	9.8
11.5	38.1	-	-	-	-	-	-	-	-	-	-	-	-	-	-	-	11.5
13.1	37.4	-	-	-	-	-	-	-	-	-	-	-	-	-	-	-	13.1
14.8	36.8	-	-	-	-	-	-	-	-	-	-	-	-	-	-	-	14.8
16.4	35.9	-	-	-	-	-	-	-	-	-	-	-	-	-	-	-	16.4
19.7	34.1	-	-	32.6	-	-	-	-	-	-	-	-	-	-	-	-	19.7
23.0	32.6	-	-	32.6	-	-	-	-	-	-	-	-	-	-	-	-	23.0
26.2	31.0	-	-	32.6	-	-	-	-	-	-	-	-	-	-	-	-	26.2
29.5	29.7	24.9	-	31.9	-	-	26.2	-	-	-	-	-	-	-	-	-	29.5
32.8	28.2	23.3	-	31.0	-	-	26.2	-	-	-	-	-	-	-	-	-	32.8
36.1	27.1	21.8	-	30.2	-	-	26.2	-	-	-	-	-	-	-	-	-	36.1
39.4	25.5	20.5	-	29.3	24.2	-	26.2	-	-	16.3	-	-	-	-	-	-	39.4
45.9	22.0	18.2	15.2	27.5	22.0	-	25.7	-	-	16.3	-	-	-	-	-	-	45.9
52.5	19.1	16.5	14.1	26.2	20.5	-	24.9	21.1	-	16.3	-	-	-	-	-	-	52.5
59.1	16.9	14.9	13.0	24.6	19.1	14.5	24.0	20.2	-	16.3	-	-	11.2	-	-	-	59.1
65.6	15.2	13.6	12.1	23.5	17.8	13.8	23.1	19.4	14.3	16.3	16.3	-	11.2	-	-	-	65.6
72.2	13.8	12.7	11.4	21.6	16.7	13.2	22.2	18.2	13.8	16.3	16.3	-	11.2	-	-	-	72.2
78.7	12.5	11.6	10.8	19.6	15.6	12.7	21.6	17.4	13.4	16.3	16.3	13.4	11.2	11.2	-	-	78.7
85.3	11.6	11.0	-	18.2	14.7	12.3	20.7	16.5	13.0	16.3	16.3	13.0	11.2	11.2	-	-	85.3
91.9	10.8	10.3	-	17.1	13.8	11.9	20.0	15.8	12.5	16.3	15.8	12.7	11.2	11.2	11.2	-	91.9
98.4	-	-	-	16.0	13.2	11.4	18.7	14.9	12.1	16.3	15.4	12.5	11.2	11.2	11.2	-	98.4
105.0	-	-	-	15.2	12.5	11.0	18.0	14.3	11.9	16.3	15.2	12.1	11.2	11.2	11.2	-	105.0
111.5	-	-	-	14.3	12.1	10.8	17.6	13.8	11.4	16.3	14.7	11.9	11.2	11.2	11.2	-	111.5
118.1	-	-	-	13.4	11.6	10.5	16.7	13.2	11.2	16.3	14.3	11.6	11.2	11.2	11.2	-	118.1
124.7	-	-	-	12.5	11.2	10.3	15.8	12.7	11.0	16.3	13.8	11.4	11.2	11.2	11.2	-	124.7
131.2	-	-	-	11.9	10.8	-	15.2	12.3	10.8	15.8	13.4	11.2	11.2	11.0	11.0	-	131.2
137.8	-	-	-	11.2	10.5	-	14.3	11.9	10.5	15.6	13.0	11.0	11.2	10.5	10.5	-	137.8
144.4	-	-	-	10.8	-	-	13.8	11.4	10.3	15.2	12.5	10.8	11.2	10.5	10.3	-	144.4
150.9	-	-	-	-	-	-	13.2	11.2	10.3	14.7	12.3	10.8	10.8	10.3	10.1	-	150.9
157.5	-	-	-	-	-	-	12.5	10.8	10.1	14.3	11.9	10.5	10.1	9.9	9.7	-	157.5
164.0	-	-	-	-	-	-	11.9	10.5	-	13.6	11.6	10.3	9.7	9.4	9.4	-	164.0
170.6	-	-	-	-	-	-	11.4	10.3	-	13.0	11.2	10.3	9.0	9.0	9.0	-	170.6
183.7	-	-	-	-	-	-	10.5	-	-	10.8	10.8	10.1	8.1	8.1	8.3	-	183.7
196.9	-	-	-	-	-	-	-	-	-	9.9	10.1	-	7.2	7.4	7.4	-	196.9
210.0	-	-	-	-	-	-	-	-	-	8.8	9.2	-	6.3	6.6	6.8	-	210.0
223.1	-	-	-	-	-	-	-	-	-	7.4	-	-	5.7	5.9	-	-	223.1
236.2	-	-	-	-	-	-	-	-	-	-	-	-	5.0	5.2	-	-	236.2
249.3	-	-	-	-	-	-	-	-	-	-	-	-	3.9	4.4	-	-	249.3
262.5	-	-	-	-	-	-	-	-	-	-	-	-	2.8	-	-	-	262.5

Operation



103,600 lbs			27.2 ft x 29.7 ft			3.6 ft + 55.4 ft			360°			ASME B30.5					
43.3 ft			98.4 ft			139.4 ft			180.4 ft			223.1 ft					
0°			20°			40°			0°			20°			40°		
ft	1,000 lbs															ft	
9.8	38.8	-	-	-	-	-	-	-	-	-	-	-	-	-	-	9.8	
11.5	38.1	-	-	-	-	-	-	-	-	-	-	-	-	-	-	11.5	
13.1	37.4	-	-	-	-	-	-	-	-	-	-	-	-	-	-	13.1	
14.8	36.8	-	-	-	-	-	-	-	-	-	-	-	-	-	-	14.8	
16.4	35.9	-	-	-	-	-	-	-	-	-	-	-	-	-	-	16.4	
19.7	34.1	-	-	32.6	-	-	-	-	-	-	-	-	-	-	-	19.7	
23.0	32.6	-	-	32.6	-	-	-	-	-	-	-	-	-	-	-	23.0	
26.2	31.0	-	-	32.6	-	-	-	-	-	-	-	-	-	-	-	26.2	
29.5	29.7	24.9	-	31.9	-	-	26.2	-	-	-	-	-	-	-	-	29.5	
32.8	28.2	23.3	-	31.0	-	-	26.2	-	-	-	-	-	-	-	-	32.8	
36.1	27.1	21.8	-	30.2	-	-	26.2	-	-	-	-	-	-	-	-	36.1	
39.4	25.5	20.5	-	29.3	24.2	-	26.2	-	-	16.3	-	-	-	-	-	39.4	
45.9	22.0	18.2	15.2	27.5	22.0	-	25.7	-	-	16.3	-	-	-	-	-	45.9	
52.5	19.1	16.5	14.1	26.2	20.5	-	24.9	21.1	-	16.3	-	-	-	-	-	52.5	
59.1	16.9	14.9	13.0	24.6	19.1	14.5	24.0	20.2	-	16.3	-	-	11.2	-	-	59.1	
65.6	15.2	13.6	12.1	23.5	17.8	13.8	23.1	19.4	14.3	16.3	16.3	-	11.2	-	-	65.6	
72.2	13.8	12.7	11.4	21.6	16.7	13.2	22.2	18.2	13.8	16.3	16.3	-	11.2	-	-	72.2	
78.7	12.5	11.6	10.8	19.6	15.6	12.7	21.6	17.4	13.4	16.3	16.3	13.4	11.2	11.2	-	78.7	
85.3	11.6	11.0	-	18.2	14.7	12.3	20.7	16.5	13.0	16.3	16.3	13.0	11.2	11.2	-	85.3	
91.9	10.8	10.3	-	17.1	13.8	11.9	20.0	15.8	12.5	16.3	15.8	12.7	11.2	11.2	11.2	91.9	
98.4	-	-	-	16.0	13.2	11.4	18.7	14.9	12.1	16.3	15.4	12.5	11.2	11.2	11.2	98.4	
105.0	-	-	-	15.2	12.5	11.0	18.0	14.3	11.9	16.3	15.2	12.1	11.2	11.2	11.2	105.0	
111.5	-	-	-	14.3	12.1	10.8	17.6	13.8	11.4	16.3	14.7	11.9	11.2	11.2	11.2	111.5	
118.1	-	-	-	13.4	11.6	10.5	16.7	13.2	11.2	16.3	14.3	11.6	11.2	11.2	11.2	118.1	
124.7	-	-	-	12.5	11.2	10.3	15.8	12.7	11.0	15.8	13.8	11.4	11.2	11.2	11.2	124.7	
131.2	-	-	-	11.9	10.8	-	15.2	12.3	10.8	14.5	13.4	11.2	11.2	11.0	11.0	131.2	
137.8	-	-	-	11.2	10.5	-	14.3	11.9	10.5	13.8	13.0	11.0	11.2	10.5	10.5	137.8	
144.4	-	-	-	10.8	-	-	13.6	11.4	10.3	12.5	12.5	10.8	11.2	10.5	10.3	144.4	
150.9	-	-	-	-	-	-	13.0	11.2	10.3	11.4	12.1	10.8	10.3	10.3	10.1	150.9	
157.5	-	-	-	-	-	-	12.1	10.8	10.1	11.0	11.4	10.5	9.2	9.9	9.7	157.5	
164.0	-	-	-	-	-	-	11.9	10.5	-	10.5	10.1	10.3	8.1	9.4	9.4	164.0	
170.6	-	-	-	-	-	-	10.8	10.3	-	9.4	9.7	9.9	7.0	8.3	9.0	170.6	
183.7	-	-	-	-	-	-	9.2	-	-	7.7	8.5	9.0	5.2	6.3	7.2	183.7	
196.9	-	-	-	-	-	-	-	-	-	6.3	6.8	-	3.9	4.8	5.5	196.9	
210.0	-	-	-	-	-	-	-	-	-	5.0	5.5	-	-	3.5	3.9	210.0	
223.1	-	-	-	-	-	-	-	-	-	3.9	-	-	-	-	-	223.1	

Operation



156,500 lbs		27.2 ft x 29.7 ft			3.6 ft + 75.1 ft			360°			ASME B30.5					
43.3 ft		98.4 ft			139.4 ft			180.4 ft			223.1 ft					
0° 20° 40°		0° 20° 40°			0° 20° 40°			0° 20° 40°			0° 20° 40°					
ft	1,000 lbs															ft
11.5	24.4	-	-	-	-	-	-	-	-	-	-	-	-	-	-	11.5
13.1	24.4	-	-	-	-	-	-	-	-	-	-	-	-	-	-	13.1
14.8	24.4	-	-	-	-	-	-	-	-	-	-	-	-	-	-	14.8
16.4	24.0	-	-	-	-	-	-	-	-	-	-	-	-	-	-	16.4
19.7	23.1	-	-	-	-	-	-	-	-	-	-	-	-	-	-	19.7
23.0	22.2	-	-	19.4	-	-	-	-	-	-	-	-	-	-	-	23.0
26.2	21.3	-	-	19.4	-	-	-	-	-	-	-	-	-	-	-	26.2
29.5	20.5	-	-	19.4	-	-	-	-	-	-	-	-	-	-	-	29.5
32.8	19.6	-	-	19.4	-	-	16.3	-	-	-	-	-	-	-	-	32.8
36.1	18.9	-	-	19.4	-	-	16.3	-	-	-	-	-	-	-	-	36.1
39.4	18.0	16.7	-	19.4	-	-	16.3	-	-	-	-	-	-	-	-	39.4
45.9	16.7	15.2	-	18.7	-	-	16.3	-	-	-	-	-	-	-	-	45.9
52.5	15.4	13.6	-	17.8	14.9	-	16.3	-	-	12.1	-	-	-	-	-	52.5
59.1	14.1	12.3	-	16.9	14.1	-	16.3	-	-	12.1	-	-	-	-	-	59.1
65.6	12.5	11.2	9.7	16.0	13.4	-	15.6	13.2	-	12.1	-	-	8.8	-	-	65.6
72.2	11.2	10.3	9.0	15.2	12.7	9.9	15.2	12.7	-	12.1	11.9	-	8.8	-	-	72.2
78.7	10.3	9.4	8.3	14.5	11.9	9.4	14.5	12.1	-	12.1	11.4	-	8.8	-	-	78.7
85.3	9.4	8.8	7.9	13.8	11.2	9.0	14.1	11.6	9.2	12.1	11.2	-	8.8	-	-	85.3
91.9	8.5	8.1	7.4	13.2	10.5	8.5	13.6	11.2	9.0	12.1	10.8	-	8.8	8.8	-	91.9
98.4	8.1	7.7	7.2	12.7	10.1	8.3	13.2	11.0	8.8	12.1	10.5	8.8	8.8	8.8	-	98.4
105.0	7.4	7.2	-	12.1	9.4	7.9	12.7	10.5	8.3	11.9	10.1	8.5	8.8	8.8	-	105.0
111.5	7.0	6.8	-	11.2	9.0	7.7	12.3	10.1	8.1	11.6	9.9	8.3	8.8	8.8	8.3	111.5
118.1	-	-	-	10.5	8.5	7.4	11.9	9.7	7.9	11.2	9.7	8.1	8.8	8.8	8.1	118.1
124.7	-	-	-	9.9	8.1	7.2	11.4	9.2	7.7	11.0	9.4	7.9	8.8	8.8	7.9	124.7
131.2	-	-	-	9.2	7.9	7.0	11.2	9.0	7.4	10.8	9.2	7.7	8.8	8.5	7.7	131.2
137.8	-	-	-	8.5	7.4	6.8	10.8	8.5	7.4	10.5	9.0	7.7	8.8	8.3	7.4	137.8
144.4	-	-	-	8.1	7.2	6.8	10.3	8.3	7.2	10.3	8.8	7.4	8.8	8.1	7.4	144.4
150.9	-	-	-	7.7	7.0	-	9.7	8.1	7.0	10.1	8.5	7.2	8.8	8.1	7.2	150.9
157.5	-	-	-	7.2	6.8	-	9.2	7.7	7.0	9.9	8.3	7.2	8.8	7.9	7.0	157.5
164.0	-	-	-	6.8	-	-	8.8	7.4	6.8	9.7	8.1	7.0	8.5	7.7	7.0	164.0
170.6	-	-	-	-	-	-	8.5	7.2	6.8	9.4	7.9	7.0	8.1	7.7	6.8	170.6
183.7	-	-	-	-	-	-	7.7	7.0	-	8.8	7.4	6.8	7.2	7.2	6.6	183.7
196.9	-	-	-	-	-	-	7.0	6.6	-	8.3	7.2	6.6	6.3	6.6	6.3	196.9
210.0	-	-	-	-	-	-	-	-	-	7.7	7.0	-	5.7	5.9	6.1	210.0
223.1	-	-	-	-	-	-	-	-	-	7.2	6.8	-	5.0	5.2	5.5	223.1
236.2	-	-	-	-	-	-	-	-	-	6.3	6.6	-	4.4	4.8	5.0	236.2
249.3	-	-	-	-	-	-	-	-	-	5.7	-	-	3.9	4.1	-	249.3
262.5	-	-	-	-	-	-	-	-	-	-	-	-	3.0	3.5	-	262.5
275.6	-	-	-	-	-	-	-	-	-	-	-	-	-	2.6	-	275.6

Operation



103,600 lbs		27.2 ft x 29.7 ft			3.6 ft + 75.1 ft			360°			ASME B30.5							
43.3 ft		98.4 ft			139.4 ft			180.4 ft			223.1 ft							
0°		20°		40°		0°		20°		40°		0°		20°		40°		
ft	1,000 lbs																ft	
11.5	24.4	-	-	-	-	-	-	-	-	-	-	-	-	-	-	-	-	11.5
13.1	24.4	-	-	-	-	-	-	-	-	-	-	-	-	-	-	-	-	13.1
14.8	24.4	-	-	-	-	-	-	-	-	-	-	-	-	-	-	-	-	14.8
16.4	24.0	-	-	-	-	-	-	-	-	-	-	-	-	-	-	-	-	16.4
19.7	23.1	-	-	-	-	-	-	-	-	-	-	-	-	-	-	-	-	19.7
23.0	22.2	-	-	19.4	-	-	-	-	-	-	-	-	-	-	-	-	-	23.0
26.2	21.3	-	-	19.4	-	-	-	-	-	-	-	-	-	-	-	-	-	26.2
29.5	20.5	-	-	19.4	-	-	-	-	-	-	-	-	-	-	-	-	-	29.5
32.8	19.6	-	-	19.4	-	-	16.3	-	-	-	-	-	-	-	-	-	-	32.8
36.1	18.9	-	-	19.4	-	-	16.3	-	-	-	-	-	-	-	-	-	-	36.1
39.4	18.0	16.7	-	19.4	-	-	16.3	-	-	-	-	-	-	-	-	-	-	39.4
45.9	16.7	15.2	-	18.7	-	-	16.3	-	-	-	-	-	-	-	-	-	-	45.9
52.5	15.4	13.6	-	17.8	14.9	-	16.3	-	-	12.1	-	-	-	-	-	-	-	52.5
59.1	14.1	12.3	-	16.9	14.1	-	16.3	-	-	12.1	-	-	-	-	-	-	-	59.1
65.6	12.5	11.2	9.7	16.0	13.4	-	15.6	13.2	-	12.1	-	-	8.8	-	-	-	-	65.6
72.2	11.2	10.3	9.0	15.2	12.7	9.9	15.2	12.7	-	12.1	11.9	-	8.8	-	-	-	-	72.2
78.7	10.3	9.4	8.3	14.5	11.9	9.4	14.5	12.1	-	12.1	11.4	-	8.8	-	-	-	-	78.7
85.3	9.4	8.8	7.9	13.8	11.2	9.0	14.1	11.6	9.2	12.1	11.2	-	8.8	-	-	-	-	85.3
91.9	8.5	8.1	7.4	13.2	10.5	8.5	13.6	11.2	9.0	12.1	10.8	-	8.8	8.8	-	-	-	91.9
98.4	8.1	7.7	7.2	12.7	10.1	8.3	13.2	11.0	8.8	12.1	10.5	8.8	8.8	8.8	-	-	-	98.4
105.0	7.4	7.2	-	12.1	9.4	7.9	12.7	10.5	8.3	11.9	10.1	8.5	8.8	8.8	-	-	-	105.0
111.5	7.0	6.8	-	11.2	9.0	7.7	12.3	10.1	8.1	11.6	9.9	8.3	8.8	8.8	8.3	-	-	111.5
118.1	-	-	-	10.5	8.5	7.4	11.9	9.7	7.9	11.2	9.7	8.1	8.8	8.8	8.1	-	-	118.1
124.7	-	-	-	9.9	8.1	7.2	11.4	9.2	7.7	11.0	9.4	7.9	8.8	8.8	7.9	-	-	124.7
131.2	-	-	-	9.2	7.9	7.0	11.2	9.0	7.4	10.8	9.2	7.7	8.8	8.5	7.7	-	-	131.2
137.8	-	-	-	8.5	7.4	6.8	10.8	8.5	7.4	10.5	9.0	7.7	8.8	8.3	7.4	-	-	137.8
144.4	-	-	-	8.1	7.2	6.8	10.3	8.3	7.2	10.3	8.8	7.4	8.8	8.1	7.4	-	-	144.4
150.9	-	-	-	7.7	7.0	-	9.7	8.1	7.0	10.1	8.5	7.2	8.8	8.1	7.2	-	-	150.9
157.5	-	-	-	7.2	6.8	-	9.2	7.7	7.0	9.7	8.3	7.2	8.8	7.9	7.0	-	-	157.5
164.0	-	-	-	6.8	-	-	8.8	7.4	6.8	9.4	8.1	7.0	8.3	7.7	7.0	-	-	164.0
170.6	-	-	-	-	-	-	8.3	7.2	6.8	8.5	7.9	7.0	7.2	7.7	6.8	-	-	170.6
183.7	-	-	-	-	-	-	7.7	7.0	-	7.9	7.4	6.8	5.5	7.0	6.6	-	-	183.7
196.9	-	-	-	-	-	-	7.0	6.6	-	6.3	7.0	6.6	3.9	5.5	6.3	-	-	196.9
210.0	-	-	-	-	-	-	-	-	-	5.0	5.9	-	-	3.9	4.8	-	-	210.0
223.1	-	-	-	-	-	-	-	-	-	3.9	4.6	-	-	-	-	-	-	223.1
236.2	-	-	-	-	-	-	-	-	-	3.0	3.5	-	-	-	-	-	-	236.2
249.3	-	-	-	-	-	-	-	-	-	2.2	-	-	-	-	-	-	-	249.3

Operation



156,500 lbs		27.2 ft x 29.7 ft			3.6 ft + 94.8 ft			360°			ASME B30.5						
43.3 ft		98.4 ft			139.4 ft			180.4 ft			223.1 ft						
0°		20°		40°		0°		20°		40°		0°		20°		40°	
ft	1,000 lbs																ft
16.4	14.3	-	-	-	-	-	-	-	-	-	-	-	-	-	-	-	16.4
19.7	14.3	-	-	-	-	-	-	-	-	-	-	-	-	-	-	-	19.7
23.0	14.3	-	-	-	-	-	-	-	-	-	-	-	-	-	-	-	23.0
26.2	14.3	-	-	13.6	-	-	-	-	-	-	-	-	-	-	-	-	26.2
29.5	14.3	-	-	13.6	-	-	-	-	-	-	-	-	-	-	-	-	29.5
32.8	14.3	-	-	13.6	-	-	-	-	-	-	-	-	-	-	-	-	32.8
36.1	14.1	-	-	13.6	-	-	-	-	-	-	-	-	-	-	-	-	36.1
39.4	13.6	-	-	13.6	-	-	11.6	-	-	-	-	-	-	-	-	-	39.4
45.9	12.7	-	-	13.4	-	-	11.6	-	-	-	-	-	-	-	-	-	45.9
52.5	11.9	10.8	-	12.7	-	-	11.6	-	-	-	-	-	-	-	-	-	52.5
59.1	11.0	9.9	-	12.3	-	-	11.4	-	-	9.0	-	-	-	-	-	-	59.1
65.6	10.3	9.2	-	11.6	9.9	-	11.2	-	-	9.0	-	-	-	-	-	-	65.6
72.2	9.7	8.8	-	11.2	9.4	-	10.8	9.2	-	9.0	-	-	6.8	-	-	-	72.2
78.7	9.0	7.9	6.8	10.8	9.0	-	10.5	8.8	-	9.0	-	-	6.8	-	-	-	78.7
85.3	8.3	7.2	6.3	10.1	8.5	-	10.1	8.5	-	9.0	7.9	-	6.8	-	-	-	85.3
91.9	7.7	6.8	5.9	9.7	8.1	6.6	9.9	8.1	-	8.8	7.7	-	6.8	-	-	-	91.9
98.4	7.0	6.3	5.7	9.2	7.9	6.3	9.4	7.9	6.6	8.5	7.4	-	6.8	-	-	-	98.4
105.0	6.3	5.9	5.2	9.0	7.4	6.1	9.2	7.7	6.3	8.3	7.2	-	6.8	6.3	-	-	105.0
111.5	5.9	5.5	5.0	8.5	7.0	5.7	8.8	7.4	6.1	8.1	7.0	-	6.8	6.3	-	-	111.5
118.1	5.5	5.0	4.8	8.1	6.8	5.5	8.5	7.2	5.9	8.1	6.8	5.9	6.8	6.1	-	-	118.1
124.7	5.0	4.8	-	7.9	6.3	5.5	8.3	7.0	5.7	7.9	6.8	5.7	6.6	6.1	-	-	124.7
131.2	4.6	4.6	-	7.4	6.1	5.2	8.1	6.8	5.5	7.7	6.6	5.7	6.6	5.9	5.7	-	131.2
137.8	-	-	-	7.0	5.7	5.0	7.7	6.6	5.2	7.4	6.3	5.5	6.6	5.7	5.5	-	137.8
144.4	-	-	-	6.6	5.5	4.8	7.4	6.3	5.2	7.4	6.1	5.2	6.3	5.7	5.2	-	144.4
150.9	-	-	-	6.1	5.2	4.8	7.2	5.9	5.0	7.2	6.1	5.2	6.3	5.7	5.2	-	150.9
157.5	-	-	-	5.7	5.0	4.6	7.0	5.7	5.0	7.0	5.9	5.0	6.1	5.5	5.0	-	157.5
164.0	-	-	-	5.5	4.8	4.6	6.8	5.7	4.8	6.8	5.9	5.0	6.1	5.5	5.0	-	164.0
170.6	-	-	-	5.2	4.6	-	6.6	5.5	4.8	6.8	5.7	4.8	5.9	5.2	4.8	-	170.6
183.7	-	-	-	4.6	-	-	5.9	5.0	4.6	6.3	5.5	4.8	5.9	5.2	4.6	-	183.7
196.9	-	-	-	-	-	-	5.5	4.8	4.4	6.1	5.2	4.6	5.7	5.0	4.6	-	196.9
210.0	-	-	-	-	-	-	5.0	4.6	-	5.7	5.0	4.6	5.0	4.8	4.4	-	210.0
223.1	-	-	-	-	-	-	4.6	-	-	5.5	4.8	4.4	4.4	4.6	4.1	-	223.1
236.2	-	-	-	-	-	-	-	-	-	5.0	4.6	-	3.9	4.1	4.1	-	236.2
249.3	-	-	-	-	-	-	-	-	-	4.8	4.4	-	3.3	3.7	3.9	-	249.3
262.5	-	-	-	-	-	-	-	-	-	4.4	-	-	2.8	3.3	-	-	262.5
275.6	-	-	-	-	-	-	-	-	-	-	-	-	-	2.8	-	-	275.6

Operation



103,600 lbs		27.2 ft x 29.7 ft			3.6 ft + 94.8 ft						360°			ASME B30.5		
43.3 ft		98.4 ft			139.4 ft			180.4 ft			223.1 ft					
0° 20° 40°		0° 20° 40°			0° 20° 40°			0° 20° 40°			0° 20° 40°					
ft		1,000 lbs											ft			
16.4	14.3	-	-	-	-	-	-	-	-	-	-	-	-	-	-	16.4
19.7	14.3	-	-	-	-	-	-	-	-	-	-	-	-	-	-	19.7
23.0	14.3	-	-	-	-	-	-	-	-	-	-	-	-	-	-	23.0
26.2	14.3	-	-	13.6	-	-	-	-	-	-	-	-	-	-	-	26.2
29.5	14.3	-	-	13.6	-	-	-	-	-	-	-	-	-	-	-	29.5
32.8	14.3	-	-	13.6	-	-	-	-	-	-	-	-	-	-	-	32.8
36.1	14.1	-	-	13.6	-	-	-	-	-	-	-	-	-	-	-	36.1
39.4	13.6	-	-	13.6	-	-	11.6	-	-	-	-	-	-	-	-	39.4
45.9	12.7	-	-	13.4	-	-	11.6	-	-	-	-	-	-	-	-	45.9
52.5	11.9	10.8	-	12.7	-	-	11.6	-	-	-	-	-	-	-	-	52.5
59.1	11.0	9.9	-	12.3	-	-	11.4	-	-	9.0	-	-	-	-	-	59.1
65.6	10.3	9.2	-	11.6	9.9	-	11.2	-	-	9.0	-	-	-	-	-	65.6
72.2	9.7	8.8	-	11.2	9.4	-	10.8	9.2	-	9.0	-	-	6.8	-	-	72.2
78.7	9.0	7.9	6.8	10.8	9.0	-	10.5	8.8	-	9.0	-	-	6.8	-	-	78.7
85.3	8.3	7.2	6.3	10.1	8.5	-	10.1	8.5	-	9.0	7.9	-	6.8	-	-	85.3
91.9	7.7	6.8	5.9	9.7	8.1	6.6	9.9	8.1	-	8.8	7.7	-	6.8	-	-	91.9
98.4	7.0	6.3	5.7	9.2	7.9	6.3	9.4	7.9	6.6	8.5	7.4	-	6.8	-	-	98.4
105.0	6.3	5.9	5.2	9.0	7.4	6.1	9.2	7.7	6.3	8.3	7.2	-	6.8	6.3	-	105.0
111.5	5.9	5.5	5.0	8.5	7.0	5.7	8.8	7.4	6.1	8.1	7.0	-	6.8	6.3	-	111.5
118.1	5.5	5.0	4.8	8.1	6.8	5.5	8.5	7.2	5.9	8.1	6.8	5.9	6.8	6.1	-	118.1
124.7	5.0	4.8	-	7.9	6.3	5.5	8.3	7.0	5.7	7.9	6.8	5.7	6.6	6.1	-	124.7
131.2	4.6	4.6	-	7.4	6.1	5.2	8.1	6.8	5.5	7.7	6.6	5.7	6.6	5.9	5.7	131.2
137.8	-	-	-	7.0	5.7	5.0	7.7	6.6	5.2	7.4	6.3	5.5	6.6	5.7	5.5	137.8
144.4	-	-	-	6.6	5.5	4.8	7.4	6.3	5.2	7.4	6.1	5.2	6.3	5.7	5.2	144.4
150.9	-	-	-	6.1	5.2	4.8	7.2	5.9	5.0	7.2	6.1	5.2	6.3	5.7	5.2	150.9
157.5	-	-	-	5.7	5.0	4.6	7.0	5.7	5.0	7.0	5.9	5.0	6.1	5.5	5.0	157.5
164.0	-	-	-	5.5	4.8	4.6	6.8	5.7	4.8	6.8	5.9	5.0	6.1	5.5	5.0	164.0
170.6	-	-	-	5.2	4.6	-	6.6	5.5	4.8	6.8	5.7	4.8	5.9	5.2	4.8	170.6
183.7	-	-	-	4.6	-	-	5.9	5.0	4.6	6.3	5.5	4.8	5.7	5.2	4.6	183.7
196.9	-	-	-	-	-	-	5.5	4.8	4.4	5.9	5.2	4.6	4.1	5.0	4.6	196.9
210.0	-	-	-	-	-	-	5.0	4.6	-	5.2	5.0	4.6	-	4.4	4.4	210.0
223.1	-	-	-	-	-	-	4.6	-	-	4.1	4.8	4.4	-	-	-	223.1
236.2	-	-	-	-	-	-	-	-	-	3.0	3.9	-	-	-	-	236.2
249.3	-	-	-	-	-	-	-	-	-	2.2	2.8	-	-	-	-	249.3

Operation

156,500 lbs		27.2 ft x 29.7 ft			3.6 ft + 114.5 ft			360°			ASME B30.5					
43.3 ft		98.4 ft			139.4 ft			180.4 ft			223.1 ft					
0° 20° 40°		0° 20° 40°			0° 20° 40°			0° 20° 40°			0° 20° 40°					
ft	1,000 lbs															ft
19.7	10.3	-	-	-	-	-	-	-	-	-	-	-	-	-	-	19.7
23.0	10.3	-	-	-	-	-	-	-	-	-	-	-	-	-	-	23.0
26.2	10.3	-	-	-	-	-	-	-	-	-	-	-	-	-	-	26.2
29.5	10.3	-	-	-	-	-	-	-	-	-	-	-	-	-	-	29.5
32.8	10.3	-	-	9.9	-	-	-	-	-	-	-	-	-	-	-	32.8
36.1	10.3	-	-	9.9	-	-	-	-	-	-	-	-	-	-	-	36.1
39.4	9.9	-	-	9.9	-	-	-	-	-	-	-	-	-	-	-	39.4
45.9	9.4	-	-	9.7	-	-	8.5	-	-	-	-	-	-	-	-	45.9
52.5	8.8	-	-	9.2	-	-	8.3	-	-	-	-	-	-	-	-	52.5
59.1	8.3	-	-	8.8	-	-	8.1	-	-	-	-	-	-	-	-	59.1
65.6	7.9	7.2	-	8.3	-	-	7.9	-	-	6.8	-	-	-	-	-	65.6
72.2	7.4	6.8	-	8.1	7.0	-	7.7	-	-	6.6	-	-	-	-	-	72.2
78.7	7.0	6.3	-	7.7	6.6	-	7.4	-	-	6.6	-	-	5.2	-	-	78.7
85.3	6.6	5.9	-	7.4	6.3	-	7.2	6.1	-	6.3	-	-	5.0	-	-	85.3
91.9	6.1	5.7	-	7.0	5.9	-	7.0	5.9	-	6.1	-	-	5.0	-	-	91.9
98.4	5.9	5.2	4.6	6.8	5.7	-	6.8	5.7	-	5.9	5.2	-	4.8	-	-	98.4
105.0	5.5	4.8	4.4	6.6	5.5	4.6	6.6	5.5	-	5.9	5.0	-	4.8	-	-	105.0
111.5	5.0	4.6	3.9	6.3	5.2	4.4	6.3	5.2	-	5.7	4.8	-	4.8	-	-	111.5
118.1	4.6	4.1	3.7	5.9	5.0	4.1	6.1	5.0	4.4	5.7	4.8	-	4.6	-	-	118.1
124.7	4.1	3.9	3.5	5.7	5.0	3.9	5.9	5.0	4.1	5.5	4.6	-	4.6	-	-	124.7
131.2	3.9	3.5	3.3	5.5	4.8	3.9	5.7	4.8	3.9	5.2	4.6	4.1	4.6	-	-	131.2
137.8	3.5	3.3	3.3	5.2	4.4	3.7	5.5	4.6	3.9	5.2	4.4	3.9	4.4	-	-	137.8
144.4	3.3	3.0	-	5.2	4.1	3.5	5.5	4.6	3.7	5.0	4.4	3.7	4.4	-	-	144.4
150.9	3.0	3.0	-	4.8	3.9	3.5	5.2	4.4	3.7	5.0	4.1	3.7	4.1	-	-	150.9
157.5	-	-	-	4.6	3.7	3.3	5.0	4.4	3.5	4.8	4.1	3.7	4.1	-	-	157.5
164.0	-	-	-	4.4	3.7	3.3	4.8	4.1	3.5	4.8	3.9	3.5	4.1	-	-	164.0
170.6	-	-	-	3.9	3.5	3.0	4.8	3.9	3.3	4.6	3.9	3.5	3.9	-	-	170.6
183.7	-	-	-	3.5	3.3	3.0	4.6	3.7	3.0	4.4	3.7	3.3	3.9	-	-	183.7
196.9	-	-	-	3.0	3.0	-	4.1	3.5	3.0	4.1	3.7	3.0	3.7	-	-	196.9
210.0	-	-	-	-	-	-	3.7	3.3	2.8	3.9	3.5	3.0	3.7	-	-	210.0
223.1	-	-	-	-	-	-	3.3	3.0	-	3.9	3.3	2.8	3.5	-	-	223.1
236.2	-	-	-	-	-	-	3.0	2.8	-	3.7	3.0	2.8	3.3	-	-	236.2
249.3	-	-	-	-	-	-	-	-	-	3.5	3.0	-	2.8	-	-	249.3
262.5	-	-	-	-	-	-	-	-	-	3.3	2.8	-	2.4	-	-	262.5
275.6	-	-	-	-	-	-	-	-	-	3.0	2.8	-	-	-	-	275.6

Operation



103,600 lbs			27.2 ft x 29.7 ft			3.6 ft + 114.5 ft			360°			ASME B30.5					
43.3 ft		98.4 ft			139.4 ft			180.4 ft			223.1 ft						
0°		20°		40°		0°		20°		40°		0°		20°		40°	
1,000 lbs																	
ft																ft	
19.7	10.3	-	-	-	-	-	-	-	-	-	-	-	-	-	-	-	19.7
23.0	10.3	-	-	-	-	-	-	-	-	-	-	-	-	-	-	-	23.0
26.2	10.3	-	-	-	-	-	-	-	-	-	-	-	-	-	-	-	26.2
29.5	10.3	-	-	-	-	-	-	-	-	-	-	-	-	-	-	-	29.5
32.8	10.3	-	-	9.9	-	-	-	-	-	-	-	-	-	-	-	-	32.8
36.1	10.3	-	-	9.9	-	-	-	-	-	-	-	-	-	-	-	-	36.1
39.4	9.9	-	-	9.9	-	-	-	-	-	-	-	-	-	-	-	-	39.4
45.9	9.4	-	-	9.7	-	-	8.5	-	-	-	-	-	-	-	-	-	45.9
52.5	8.8	-	-	9.2	-	-	8.3	-	-	-	-	-	-	-	-	-	52.5
59.1	8.3	-	-	8.8	-	-	8.1	-	-	-	-	-	-	-	-	-	59.1
65.6	7.9	7.2	-	8.3	-	-	7.9	-	-	6.8	-	-	-	-	-	-	65.6
72.2	7.4	6.8	-	8.1	7.0	-	7.7	-	-	6.6	-	-	-	-	-	-	72.2
78.7	7.0	6.3	-	7.7	6.6	-	7.4	-	-	6.6	-	-	5.2	-	-	-	78.7
85.3	6.6	5.9	-	7.4	6.3	-	7.2	6.1	-	6.3	-	-	5.0	-	-	-	85.3
91.9	6.1	5.7	-	7.0	5.9	-	7.0	5.9	-	6.1	-	-	5.0	-	-	-	91.9
98.4	5.9	5.2	4.6	6.8	5.7	-	6.8	5.7	-	5.9	5.2	-	4.8	-	-	-	98.4
105.0	5.5	4.8	4.4	6.6	5.5	4.6	6.6	5.5	-	5.9	5.0	-	4.8	-	-	-	105.0
111.5	5.0	4.6	3.9	6.3	5.2	4.4	6.3	5.2	-	5.7	4.8	-	4.8	-	-	-	111.5
118.1	4.6	4.1	3.7	5.9	5.0	4.1	6.1	5.0	4.4	5.7	4.8	-	4.6	-	-	-	118.1
124.7	4.1	3.9	3.5	5.7	5.0	3.9	5.9	5.0	4.1	5.5	4.6	-	4.6	-	-	-	124.7
131.2	3.9	3.5	3.3	5.5	4.8	3.9	5.7	4.8	3.9	5.2	4.6	4.1	4.6	-	-	-	131.2
137.8	3.5	3.3	3.3	5.2	4.4	3.7	5.5	4.6	3.9	5.2	4.4	3.9	4.4	-	-	-	137.8
144.4	3.3	3.0	-	5.2	4.1	3.5	5.5	4.6	3.7	5.0	4.4	3.7	4.4	-	-	-	144.4
150.9	3.0	3.0	-	4.8	3.9	3.5	5.2	4.4	3.7	5.0	4.1	3.7	4.1	-	-	-	150.9
157.5	-	-	-	4.6	3.7	3.3	5.0	4.4	3.5	4.8	4.1	3.7	4.1	-	-	-	157.5
164.0	-	-	-	4.4	3.7	3.3	4.8	4.1	3.5	4.8	3.9	3.5	4.1	-	-	-	164.0
170.6	-	-	-	3.9	3.5	3.0	4.8	3.9	3.3	4.6	3.9	3.5	3.9	-	-	-	170.6
183.7	-	-	-	3.5	3.3	3.0	4.6	3.7	3.0	4.4	3.7	3.3	3.9	-	-	-	183.7
196.9	-	-	-	3.0	3.0	-	4.1	3.5	3.0	4.1	3.7	3.0	-	-	-	-	196.9
210.0	-	-	-	-	-	-	3.7	3.3	2.8	3.9	3.5	3.0	-	-	-	-	210.0
223.1	-	-	-	-	-	-	3.3	3.0	-	3.7	3.3	2.8	-	-	-	-	223.1
236.2	-	-	-	-	-	-	3.0	2.8	-	3.0	3.0	2.8	-	-	-	-	236.2
249.3	-	-	-	-	-	-	-	-	-	2.2	3.0	-	-	-	-	-	249.3

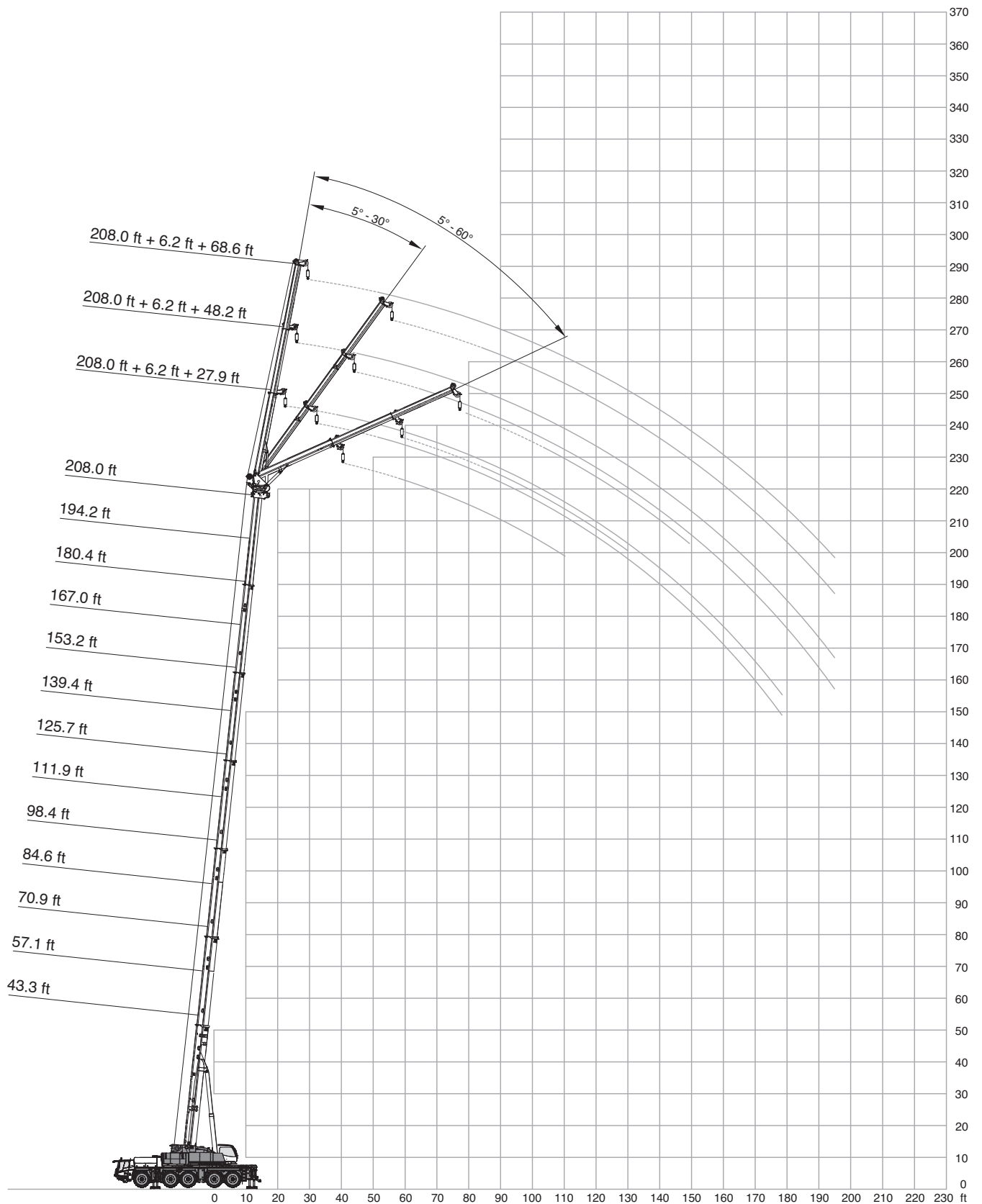

Operation

HTLJ

156,500 lbs		27.2 ft x 29.7 ft			6.2 ft + 27.9 ft			360°			ASME B30.5				
43.3 ft		98.4 ft			139.4 ft			180.4 ft			208.0 ft				
5° 30° 60°		5° 30° 60°			5° 30° 60°			5° 30° 60°			5° 30° 60°				
ft	1,000 lbs												ft		
11.5	58.2	-	-	-	-	-	-	-	-	-	-	-	-	-	11.5
13.1	54.8	-	-	-	-	-	-	-	-	-	-	-	-	-	13.1
14.8	51.8	-	-	-	-	-	-	-	-	-	-	-	-	-	14.8
16.4	49.1	-	-	66.1	-	-	-	-	-	-	-	-	-	-	16.4
19.7	44.3	-	-	61.9	-	-	-	-	-	-	-	-	-	-	19.7
23.0	40.5	33.5	-	57.5	-	-	46.9	-	-	-	-	-	-	-	23.0
26.2	37.2	31.9	-	53.7	-	-	46.9	-	-	-	-	-	-	-	26.2
29.5	34.3	30.6	27.1	50.2	35.0	-	46.9	-	-	22.4	-	-	-	-	29.5
32.8	31.9	29.3	26.6	47.3	33.9	-	46.9	-	-	25.3	-	-	-	-	32.8
36.1	29.7	28.2	26.4	44.7	33.0	27.3	46.9	35.0	-	25.3	-	-	-	-	36.1
39.4	27.9	27.3	26.4	42.3	32.1	27.1	46.2	34.3	-	25.3	-	-	15.4	-	39.4
45.9	24.9	25.5	-	38.1	30.6	26.6	42.9	32.8	27.1	25.3	25.1	-	15.4	-	45.9
52.5	22.2	24.4	-	34.8	29.1	26.4	39.9	31.5	26.6	24.6	23.3	22.9	14.9	13.8	52.5
59.1	20.2	24.0	-	31.9	27.9	26.2	36.8	30.4	26.4	23.1	21.8	21.3	13.8	13.0	59.1
65.6	18.9	-	-	29.5	26.8	26.2	33.9	29.3	26.0	21.6	20.5	20.0	13.2	12.1	65.6
72.2	-	-	-	27.3	26.0	-	31.5	28.4	25.7	20.2	19.1	18.9	12.3	11.2	72.2
78.7	-	-	-	25.5	25.3	-	29.1	27.5	25.7	18.7	18.0	17.8	11.6	10.5	78.7
85.3	-	-	-	24.0	24.6	-	27.1	26.6	25.7	17.4	16.9	16.7	10.8	10.1	85.3
91.9	-	-	-	22.7	24.2	-	25.3	24.9	-	16.0	15.8	15.8	10.1	9.4	91.9
98.4	-	-	-	21.3	23.8	-	23.5	23.3	-	14.9	14.7	14.9	9.4	9.0	98.4
105.0	-	-	-	20.2	23.1	-	22.0	21.8	-	13.8	13.8	-	8.8	8.5	105.0
111.5	-	-	-	19.4	-	-	18.9	20.0	-	13.0	13.0	-	8.3	7.9	111.5
118.1	-	-	-	18.5	-	-	16.0	17.1	-	12.1	12.1	-	7.9	7.4	118.1
124.7	-	-	-	-	-	-	13.6	14.5	-	11.2	11.2	-	7.2	7.0	124.7
131.2	-	-	-	-	-	-	11.4	12.1	-	10.5	10.5	-	6.8	6.6	131.2
137.8	-	-	-	-	-	-	9.7	10.1	-	9.0	9.9	-	6.6	6.1	137.8
144.4	-	-	-	-	-	-	8.3	8.5	-	8.3	8.3	-	6.1	5.9	144.4
150.9	-	-	-	-	-	-	7.4	-	-	7.7	7.7	-	5.2	5.5	150.9
157.5	-	-	-	-	-	-	5.7	-	-	6.6	7.0	-	5.0	4.8	157.5
164.0	-	-	-	-	-	-	5.0	-	-	5.2	5.7	-	4.6	4.6	164.0
180.4	-	-	-	-	-	-	-	-	-	3.0	-	-	3.5	3.7	180.4

Operation

HTLJ

103,600 lbs		27.2 ft x 29.7 ft			6.2 ft + 27.9 ft			360°			ASME B30.5						
43.3 ft		98.4 ft			139.4 ft			180.4 ft			208.0 ft						
5° 30° 60°		5° 30° 60°			5° 30° 60°			5° 30° 60°			5° 30° 60°						
ft	1,000 lbs															ft	
11.5	58.2	-	-	-	-	-	-	-	-	-	-	-	-	-	-	-	11.5
13.1	54.8	-	-	-	-	-	-	-	-	-	-	-	-	-	-	-	13.1
14.8	51.8	-	-	-	-	-	-	-	-	-	-	-	-	-	-	-	14.8
16.4	49.1	-	-	66.1	-	-	-	-	-	-	-	-	-	-	-	-	16.4
19.7	44.3	-	-	61.9	-	-	-	-	-	-	-	-	-	-	-	-	19.7
23.0	40.5	33.5	-	57.5	-	-	46.9	-	-	-	-	-	-	-	-	-	23.0
26.2	37.2	31.9	-	53.7	-	-	46.9	-	-	-	-	-	-	-	-	-	26.2
29.5	34.3	30.6	27.1	50.2	35.0	-	46.9	-	-	22.4	-	-	-	-	-	-	29.5
32.8	31.9	29.3	26.6	47.3	33.9	-	46.9	-	-	25.3	-	-	-	-	-	-	32.8
36.1	29.7	28.2	26.4	44.7	33.0	27.3	46.9	35.0	-	25.3	-	-	-	-	-	-	36.1
39.4	27.9	27.3	26.4	42.3	32.1	27.1	46.2	34.3	-	25.3	-	-	15.4	-	-	-	39.4
45.9	24.9	25.5	-	38.1	30.6	26.6	42.9	32.8	27.1	25.3	25.1	-	15.4	-	-	-	45.9
52.5	22.2	24.4	-	34.8	29.1	26.4	39.9	31.5	26.6	24.6	23.3	22.9	14.9	13.8	-	-	52.5
59.1	20.2	24.0	-	31.9	27.9	26.2	36.8	30.4	26.4	23.1	21.8	21.3	13.8	13.0	12.3	-	59.1
65.6	18.9	-	-	29.5	26.8	26.2	33.9	29.3	26.0	21.6	20.5	20.0	13.2	12.1	11.6	-	65.6
72.2	-	-	-	27.3	26.0	-	31.5	28.4	25.7	20.2	19.1	18.9	12.3	11.2	11.0	-	72.2
78.7	-	-	-	25.3	25.3	-	26.0	27.5	25.7	18.7	18.0	17.8	11.6	10.5	10.3	-	78.7
85.3	-	-	-	23.8	24.6	-	21.3	23.5	24.9	17.4	16.9	16.7	10.8	10.1	9.7	-	85.3
91.9	-	-	-	22.2	22.2	-	19.4	19.4	-	16.0	15.8	15.8	10.1	9.4	9.2	-	91.9
98.4	-	-	-	19.1	20.0	-	17.6	17.6	-	14.9	14.7	14.9	9.4	9.0	8.8	-	98.4
105.0	-	-	-	16.3	16.9	-	14.9	16.0	-	13.2	13.8	-	8.8	8.5	8.3	-	105.0
111.5	-	-	-	13.8	-	-	12.5	13.4	-	12.1	12.1	-	8.3	7.9	7.9	-	111.5
118.1	-	-	-	11.9	-	-	10.3	11.2	-	10.5	10.8	-	7.9	7.4	-	-	118.1
124.7	-	-	-	-	-	-	9.2	9.4	-	8.5	9.7	-	7.2	7.0	-	-	124.7
131.2	-	-	-	-	-	-	8.3	8.5	-	7.7	7.9	-	6.6	6.6	-	-	131.2
137.8	-	-	-	-	-	-	7.4	7.7	-	6.8	7.0	-	-	6.1	-	-	137.8
144.4	-	-	-	-	-	-	6.8	4.1	-	5.5	6.1	-	-	-	-	-	144.4
150.9	-	-	-	-	-	-	5.5	-	-	4.4	5.2	-	-	-	-	-	150.9
157.5	-	-	-	-	-	-	4.8	-	-	3.3	3.9	-	-	-	-	-	157.5
164.0	-	-	-	-	-	-	4.6	-	-	-	2.8	-	-	-	-	-	164.0

Operation

HTLJ

156,500 lbs			27.2 ft x 29.7 ft			6.2 ft + 48.2 ft			360°			ASME B30.5					
43.3 ft		98.4 ft			139.4 ft			180.4 ft			208.0 ft						
5°		30°		60°		5°		30°		60°		5°		30°		60°	
1,000 lbs																	
ft																	ft
16.4	30.6	-	-	-	-	-	-	-	-	-	-	-	-	-	-	-	16.4
19.7	30.6	-	-	-	-	-	-	-	-	-	-	-	-	-	-	-	19.7
23.0	30.6	-	-	30.6	-	-	-	-	-	-	-	-	-	-	-	-	23.0
26.2	27.9	-	-	30.6	-	-	-	-	-	-	-	-	-	-	-	-	26.2
29.5	25.7	-	-	30.6	-	-	30.6	-	-	-	-	-	-	-	-	-	29.5
32.8	23.5	-	-	30.6	-	-	30.6	-	-	-	-	-	-	-	-	-	32.8
36.1	21.8	19.1	-	30.6	-	-	30.6	-	-	15.2	-	-	-	-	-	-	36.1
39.4	20.2	18.2	-	29.5	20.5	-	30.4	-	-	15.2	-	-	-	-	-	-	39.4
45.9	17.8	16.7	-	26.4	19.4	-	28.8	-	-	15.2	-	-	11.9	-	-	-	45.9
52.5	15.6	15.4	14.1	23.8	18.2	-	27.3	19.4	-	15.2	-	-	11.9	-	-	-	52.5
59.1	14.1	14.3	13.8	21.6	17.1	14.3	26.2	18.5	-	15.2	15.2	-	11.9	-	-	-	59.1
65.6	12.7	13.6	-	19.6	16.5	14.1	24.0	17.6	14.3	15.2	15.2	-	11.4	10.1	-	-	65.6
72.2	11.4	13.0	-	18.0	15.6	13.8	22.2	16.9	14.1	15.2	15.2	-	10.5	9.4	-	-	72.2
78.7	10.5	12.5	-	16.7	14.9	13.8	20.5	16.3	14.1	15.2	15.2	14.1	9.9	9.0	-	-	78.7
85.3	9.9	-	-	15.4	14.5	13.8	19.1	15.8	13.8	15.2	14.7	13.8	9.4	8.5	8.1	-	85.3
91.9	-	-	-	14.3	13.8	-	17.8	15.2	13.8	14.7	13.8	13.6	8.8	7.9	7.7	-	91.9
98.4	-	-	-	13.4	13.4	-	16.7	14.7	13.6	13.8	13.2	13.0	8.3	7.7	7.2	-	98.4
105.0	-	-	-	12.5	13.2	-	15.8	14.3	13.6	13.2	12.5	12.3	7.9	7.2	7.0	-	105.0
111.5	-	-	-	11.9	12.7	-	14.9	13.8	-	12.3	11.9	11.9	7.4	6.8	6.6	-	111.5
118.1	-	-	-	11.2	12.5	-	14.1	13.6	-	11.4	11.2	11.2	7.0	6.3	6.1	-	118.1
124.7	-	-	-	10.5	12.5	-	13.4	13.2	-	10.8	10.8	-	6.6	6.1	5.9	-	124.7
131.2	-	-	-	10.1	-	-	12.7	13.0	-	10.1	10.1	-	6.1	5.7	5.7	-	131.2
137.8	-	-	-	9.7	-	-	12.1	12.5	-	9.4	9.4	-	5.9	5.5	-	-	137.8
144.4	-	-	-	-	-	-	10.8	12.1	-	8.8	8.8	-	5.5	5.2	-	-	144.4
150.9	-	-	-	-	-	-	9.2	10.1	-	7.7	8.3	-	5.2	5.0	-	-	150.9
157.5	-	-	-	-	-	-	7.7	8.5	-	7.2	7.9	-	4.8	4.6	-	-	157.5
164.0	-	-	-	-	-	-	6.8	7.0	-	6.6	6.8	-	4.6	4.4	-	-	164.0
180.4	-	-	-	-	-	-	4.4	-	-	4.6	5.5	-	3.5	3.5	-	-	180.4
196.9	-	-	-	-	-	-	-	-	-	2.6	2.8	-	3.0	2.8	-	-	196.9

Operation

HTLJ

103,600 lbs			27.2 ft x 29.7 ft			6.2 ft + 48.2 ft			360°			ASME B30.5					
43.3 ft		98.4 ft			139.4 ft			180.4 ft			208.0 ft						
5°		30°		60°		5°		30°		60°		5°		30°		60°	
1,000 lbs																	
ft																ft	
16.4	30.6	-	-	-	-	-	-	-	-	-	-	-	-	-	-	-	16.4
19.7	30.6	-	-	-	-	-	-	-	-	-	-	-	-	-	-	-	19.7
23.0	30.6	-	-	30.6	-	-	-	-	-	-	-	-	-	-	-	-	23.0
26.2	27.9	-	-	30.6	-	-	-	-	-	-	-	-	-	-	-	-	26.2
29.5	25.7	-	-	30.6	-	-	30.6	-	-	-	-	-	-	-	-	-	29.5
32.8	23.5	-	-	30.6	-	-	30.6	-	-	-	-	-	-	-	-	-	32.8
36.1	21.8	19.1	-	30.6	-	-	30.6	-	-	15.2	-	-	-	-	-	-	36.1
39.4	20.2	18.2	-	29.5	20.5	-	30.4	-	-	15.2	-	-	-	-	-	-	39.4
45.9	17.8	16.7	-	26.4	19.4	-	28.8	-	-	15.2	-	-	11.9	-	-	-	45.9
52.5	15.6	15.4	14.1	23.8	18.2	-	27.3	19.4	-	15.2	-	-	11.9	-	-	-	52.5
59.1	14.1	14.3	13.8	21.6	17.1	14.3	26.2	18.5	-	15.2	15.2	-	11.9	-	-	-	59.1
65.6	12.7	13.6	-	19.6	16.5	14.1	24.0	17.6	14.3	15.2	15.2	-	11.4	10.1	-	-	65.6
72.2	11.4	13.0	-	18.0	15.6	13.8	22.2	16.9	14.1	15.2	15.2	-	10.5	9.4	-	-	72.2
78.7	10.5	12.5	-	16.7	14.9	13.8	20.5	16.3	14.1	15.2	15.2	14.1	9.9	9.0	-	-	78.7
85.3	9.9	-	-	15.4	14.5	13.8	19.1	15.8	13.8	15.2	14.7	13.8	9.4	8.5	8.1	-	85.3
91.9	-	-	-	14.3	13.8	-	17.8	15.2	13.8	14.7	13.8	13.6	8.8	7.9	7.7	-	91.9
98.4	-	-	-	13.4	13.4	-	16.7	14.7	13.6	13.8	13.2	13.0	8.3	7.7	7.2	-	98.4
105.0	-	-	-	12.5	13.2	-	15.8	14.3	13.6	13.2	12.5	12.3	7.9	7.2	7.0	-	105.0
111.5	-	-	-	11.9	12.7	-	14.7	13.8	-	12.3	11.9	11.9	7.4	6.8	6.6	-	111.5
118.1	-	-	-	11.2	12.5	-	13.0	13.6	-	11.4	11.2	11.2	7.0	6.3	6.1	-	118.1
124.7	-	-	-	10.5	12.5	-	11.0	12.5	-	9.4	10.8	-	6.6	6.1	5.9	-	124.7
131.2	-	-	-	10.1	-	-	9.2	10.8	-	8.8	9.7	-	6.1	5.7	5.7	-	131.2
137.8	-	-	-	9.7	-	-	8.1	9.0	-	7.7	7.9	-	5.9	5.5	-	-	137.8
144.4	-	-	-	-	-	-	7.2	7.4	-	6.3	7.7	-	5.5	5.2	-	-	144.4
150.9	-	-	-	-	-	-	6.6	6.8	-	5.9	6.3	-	-	5.0	-	-	150.9
157.5	-	-	-	-	-	-	5.9	6.1	-	5.2	5.2	-	-	-	-	-	157.5
164.0	-	-	-	-	-	-	5.2	3.3	-	4.1	4.8	-	-	-	-	-	164.0
180.4	-	-	-	-	-	-	3.5	-	-	-	-	-	-	-	-	-	180.4

Operation

HTLJ

156,500 lbs			27.2 ft x 29.7 ft			6.2 ft + 68.6 ft			360°			ASME B30.5		
43.3 ft		98.4 ft			139.4 ft			180.4 ft			208.0 ft			
5°	30°	60°	5°	30°	60°	5°	30°	60°	5°	30°	60°	5°	30°	60°
1,000 lbs														
ft														ft
23.0	12.3	-	-	-	-	-	-	-	-	-	-	-	-	23.0
26.2	12.3	-	-	12.3	-	-	-	-	-	-	-	-	-	26.2
29.5	12.3	-	-	12.3	-	-	-	-	-	-	-	-	-	29.5
32.8	12.3	-	-	12.3	-	-	12.3	-	-	-	-	-	-	32.8
36.1	12.3	-	-	12.3	-	-	12.3	-	-	-	-	-	-	36.1
39.4	12.3	-	-	12.3	-	-	12.3	-	-	-	-	-	-	39.4
45.9	12.3	-	-	12.3	-	-	12.3	-	-	12.3	-	-	-	45.9
52.5	12.3	12.3	-	12.3	-	-	12.3	-	-	12.3	-	-	9.2	52.5
59.1	11.6	11.4	-	12.3	12.3	-	12.3	-	-	12.3	-	-	9.2	59.1
65.6	10.5	10.5	-	12.3	12.3	-	12.3	12.3	-	12.3	-	-	9.2	65.6
72.2	9.4	9.9	8.3	12.3	11.6	-	12.3	12.1	-	12.3	-	-	9.2	72.2
78.7	8.5	9.2	8.1	12.3	11.0	8.8	12.3	11.6	-	12.3	11.0	-	8.8	78.7
85.3	7.7	8.5	-	11.9	10.5	8.5	12.3	11.2	8.5	12.3	10.5	-	8.3	85.3
91.9	7.0	8.1	-	11.0	10.1	8.5	12.3	10.8	8.5	12.3	10.3	-	7.9	91.9
98.4	6.6	7.9	-	10.3	9.7	8.3	12.3	10.5	8.3	12.1	10.1	8.5	7.2	98.4
105.0	5.9	-	-	9.4	9.2	8.3	11.9	10.1	8.3	11.6	9.7	8.3	7.0	105.0
111.5	-	-	-	9.0	9.0	-	11.2	9.9	8.1	11.4	9.4	8.3	6.6	111.5
118.1	-	-	-	8.3	8.5	-	10.5	9.4	8.1	10.8	9.2	8.1	6.1	118.1
124.7	-	-	-	7.9	8.3	-	9.9	9.2	8.1	10.3	9.0	8.1	5.9	124.7
131.2	-	-	-	7.4	8.1	-	9.4	9.0	-	9.7	8.8	8.1	5.5	131.2
137.8	-	-	-	7.0	7.9	-	8.8	8.8	-	9.2	8.5	8.1	5.2	137.8
144.4	-	-	-	6.6	7.9	-	8.3	8.5	-	8.5	8.3	-	5.0	144.4
150.9	-	-	-	6.1	7.9	-	7.9	8.3	-	8.1	8.1	-	4.8	150.9
157.5	-	-	-	5.9	-	-	7.7	8.1	-	7.7	7.7	-	4.4	157.5
164.0	-	-	-	5.7	-	-	7.2	7.9	-	7.2	7.2	-	4.1	164.0
180.4	-	-	-	-	-	-	5.9	6.8	-	5.7	6.3	-	3.5	180.4
196.9	-	-	-	-	-	-	4.4	-	-	4.1	5.0	-	2.8	196.9

103,600 lbs			27.2 ft x 29.7 ft			6.2 ft + 68.6 ft			360°			ASME B30.5		
43.3 ft		98.4 ft			139.4 ft			180.4 ft			208.0 ft			
5°	30°	60°	5°	30°	60°	5°	30°	60°	5°	30°	60°	5°	30°	60°
1,000 lbs														
ft														ft
23.0	12.3	-	-	-	-	-	-	-	-	-	-	-	-	23.0
26.2	12.3	-	-	12.3	-	-	-	-	-	-	-	-	-	26.2
29.5	12.3	-	-	12.3	-	-	-	-	-	-	-	-	-	29.5
32.8	12.3	-	-	12.3	-	-	12.3	-	-	-	-	-	-	32.8
36.1	12.3	-	-	12.3	-	-	12.3	-	-	-	-	-	-	36.1
39.4	12.3	-	-	12.3	-	-	12.3	-	-	-	-	-	-	39.4
45.9	12.3	-	-	12.3	-	-	12.3	-	-	12.3	-	-	-	45.9
52.5	12.3	12.3	-	12.3	-	-	12.3	-	-	12.3	-	-	9.2	52.5
59.1	11.6	11.4	-	12.3	12.3	-	12.3	-	-	12.3	-	-	9.2	59.1
65.6	10.5	10.5	-	12.3	12.3	-	12.3	12.3	-	12.3	-	-	9.2	65.6
72.2	9.4	9.9	8.3	12.3	11.6	-	12.3	12.1	-	12.3	-	-	9.2	72.2
78.7	8.5	9.2	8.1	12.3	11.0	8.8	12.3	11.6	-	12.3	11.0	-	8.8	78.7
85.3	7.7	8.5	-	11.9	10.5	8.5	12.3	11.2	8.5	12.3	10.5	-	8.3	85.3
91.9	7.0	8.1	-	11.0	10.1	8.5	12.3	10.8	8.5	12.3	10.3	-	7.9	91.9
98.4	6.6	7.9	-	10.3	9.7	8.3	12.3	10.5	8.3	12.1	10.1	8.5	7.2	98.4
105.0	5.9	-	-	9.4	9.2	8.3	11.9	10.1	8.3	11.6	9.7	8.3	7.0	105.0
111.5	-	-	-	9.0	9.0	-	11.2	9.9	8.1	11.4	9.4	8.3	6.6	111.5
118.1	-	-	-	8.3	8.5	-	10.5	9.4	8.1	10.8	9.2	8.1	6.1	118.1
124.7	-	-	-	7.9	8.3	-	9.9	9.2	8.1	10.3	9.0	8.1	5.9	124.7
131.2	-	-	-	7.4	8.1	-	9.4	9.0	-	9.4	8.8	8.1	5.5	131.2
137.8	-	-	-	7.0	7.9	-	8.8	8.8	-	7.9	8.5	8.1	5.2	137.8
144.4	-	-	-	6.6	7.9	-	8.3	8.5	-	7.0	8.3	-	5.0	144.4
150.9	-	-	-	6.1	5.9	-	7.2	8.3	-	6.8	7.7	-	4.8	150.9
157.5	-	-	-	5.9	-	-	6.3	7.7	-	5.7	6.1	-	3.9	157.5
164.0	-	-	-	5.7	-	-	5.9	6.3	-	4.8	5.7	-	3.9	164.0
180.4	-	-	-	-	-	-	4.6	4.8	-	3.5	3.7	-	-	180.4
196.9	-	-	-	-	-	-	3.0	-	-	-	-	-	-	196.9

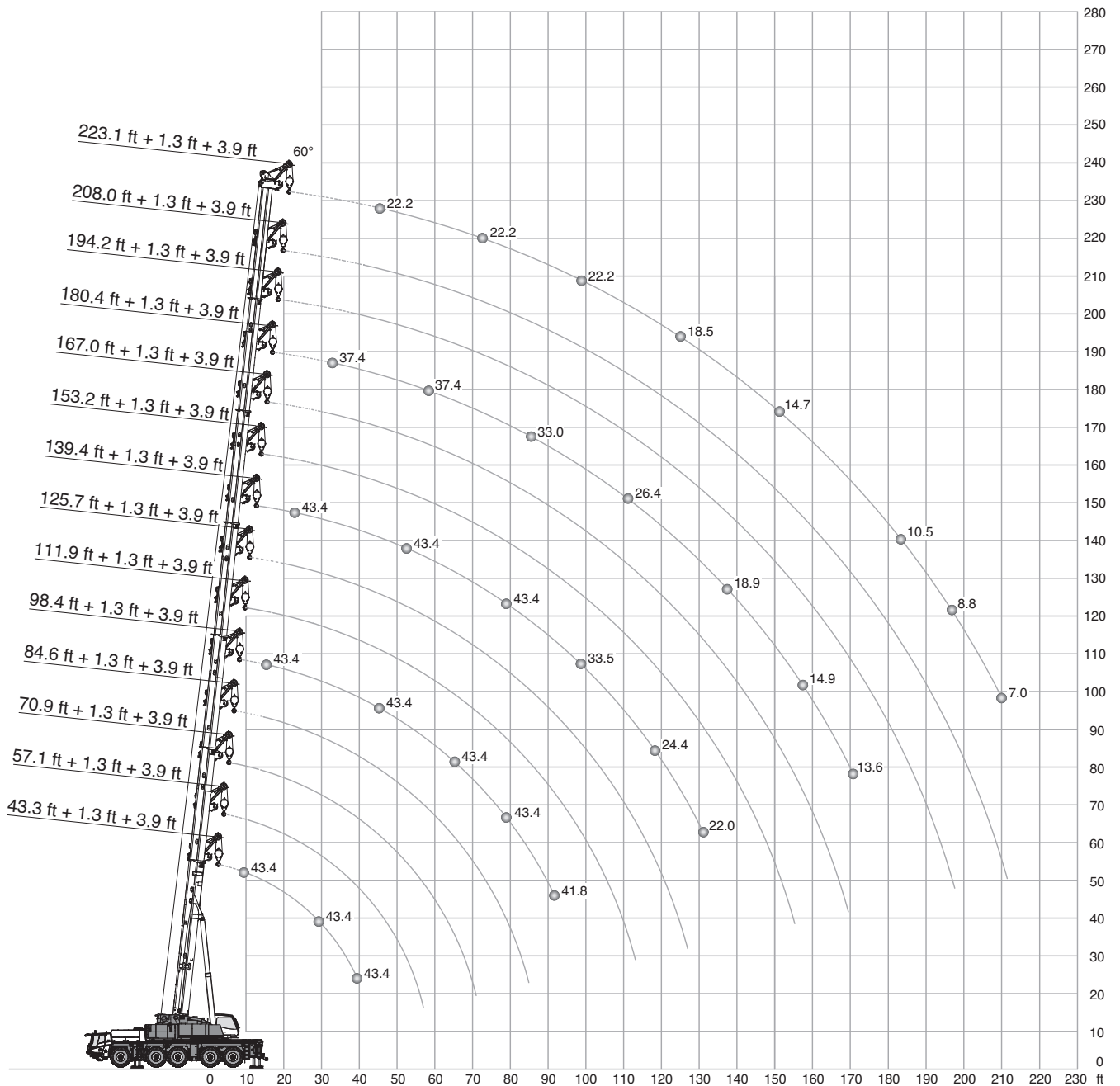

Operation

156,500 lbs		27.2 ft x 29.7 ft		1.3 ft + 3.9 ft		360°		ASME B30.5	
43.3 ft 60°		98.4 ft 60°		139.4 ft 60°		180.4 ft 60°		223.1 ft 60°	
ft	1,000 lbs								ft
9.8	43.4	-	-	-	-	-	-	-	9.8
11.5	43.4	-	-	-	-	-	-	-	11.5
13.1	43.4	-	-	-	-	-	-	-	13.1
14.8	43.4	43.4	-	-	-	-	-	-	14.8
16.4	43.4	43.4	-	-	-	-	-	-	16.4
19.7	43.4	43.4	-	-	-	-	-	-	19.7
23.0	43.4	43.4	43.4	-	-	-	-	-	23.0
26.2	43.4	43.4	43.4	-	-	-	-	-	26.2
29.5	43.4	43.4	43.4	-	-	-	-	-	29.5
32.8	43.4	43.4	43.4	43.4	37.4	-	-	-	32.8
36.1	43.4	43.4	43.4	43.4	37.4	-	-	-	36.1
39.4	43.4	43.4	43.4	43.4	37.4	-	-	-	39.4
45.9	-	43.4	43.4	43.4	37.4	22.2	-	-	45.9
52.5	-	43.4	43.4	43.4	37.4	22.2	-	-	52.5
59.1	-	43.4	43.4	43.4	37.4	22.2	-	-	59.1
65.6	-	43.4	43.4	43.4	37.4	22.2	-	-	65.6
72.2	-	43.4	43.4	43.4	37.2	22.2	-	-	72.2
78.7	-	43.4	43.4	43.4	35.0	22.2	-	-	78.7
85.3	-	43.4	42.9	42.9	33.0	22.2	-	-	85.3
91.9	-	41.8	37.6	37.6	31.0	22.2	-	-	91.9
98.4	-	-	33.5	33.5	29.5	22.2	-	-	98.4
105.0	-	-	29.7	29.7	27.9	22.2	-	-	105.0
111.5	-	-	26.4	26.4	26.4	20.9	-	-	111.5
118.1	-	-	24.4	24.4	25.1	19.6	-	-	118.1
124.7	-	-	23.1	23.1	23.1	18.5	-	-	124.7
131.2	-	-	22.0	22.0	20.9	17.4	-	-	131.2
137.8	-	-	-	-	18.9	16.3	-	-	137.8
144.4	-	-	-	-	17.1	15.4	-	-	144.4
150.9	-	-	-	-	15.6	14.7	-	-	150.9
157.5	-	-	-	-	14.9	13.8	-	-	157.5
164.0	-	-	-	-	14.3	13.0	-	-	164.0
170.6	-	-	-	-	13.6	12.3	-	-	170.6
183.7	-	-	-	-	-	10.5	-	-	183.7
196.9	-	-	-	-	-	8.8	-	-	196.9
210.0	-	-	-	-	-	7.0	-	-	210.0

Operation



103,600 lbs		27.2 ft x 29.7 ft		1.3 ft + 3.9 ft		360°		ASME B30.5	
43.3 ft 60°		98.4 ft 60°		139.4 ft 60°		180.4 ft 60°		223.1 ft 60°	
ft	1,000 lbs								ft
9.8	43.4	-	-	-	-	-	-	-	9.8
11.5	43.4	-	-	-	-	-	-	-	11.5
13.1	43.4	-	-	-	-	-	-	-	13.1
14.8	43.4	43.4	-	-	-	-	-	-	14.8
16.4	43.4	43.4	-	-	-	-	-	-	16.4
19.7	43.4	43.4	-	-	-	-	-	-	19.7
23.0	43.4	43.4	43.4	-	-	-	-	-	23.0
26.2	43.4	43.4	43.4	43.4	-	-	-	-	26.2
29.5	43.4	43.4	43.4	43.4	-	-	-	-	29.5
32.8	43.4	43.4	43.4	43.4	37.4	-	-	-	32.8
36.1	43.4	43.4	43.4	43.4	37.4	-	-	-	36.1
39.4	43.4	43.4	43.4	43.4	37.4	-	-	-	39.4
45.9	-	43.4	43.4	43.4	37.4	22.2	-	-	45.9
52.5	-	43.4	43.4	43.4	37.4	22.2	-	-	52.5
59.1	-	43.4	43.4	43.4	37.4	22.2	-	-	59.1
65.6	-	43.4	43.4	43.4	37.4	22.2	-	-	65.6
72.2	-	43.4	39.9	37.2	22.2	-	-	-	72.2
78.7	-	40.5	36.3	35.0	22.2	-	-	-	78.7
85.3	-	35.7	33.5	31.5	22.2	-	-	-	85.3
91.9	-	31.5	29.3	27.5	22.2	-	-	-	91.9
98.4	-	-	25.7	24.0	22.2	-	-	-	98.4
105.0	-	-	24.0	22.9	22.2	-	-	-	105.0
111.5	-	-	22.7	21.8	20.0	-	-	-	111.5
118.1	-	-	20.7	20.0	17.8	-	-	-	118.1
124.7	-	-	18.7	18.0	15.8	-	-	-	124.7
131.2	-	-	17.6	16.3	14.1	-	-	-	131.2
137.8	-	-	-	14.7	12.5	-	-	-	137.8
144.4	-	-	-	13.2	11.0	-	-	-	144.4
150.9	-	-	-	11.9	9.7	-	-	-	150.9
157.5	-	-	-	10.8	8.5	-	-	-	157.5
164.0	-	-	-	9.7	7.4	-	-	-	164.0
170.6	-	-	-	8.8	6.6	-	-	-	170.6
183.7	-	-	-	-	4.8	-	-	-	183.7
196.9	-	-	-	-	3.3	-	-	-	196.9

Notes to Lifting Capacity

Ratings are in compliance with ASME B30.5.
Lifting capacities do not exceed 85 % of tipping load.

Weight of hook blocks and slings is part of the load, and is to be deducted from the capacity ratings.
Consult operation manual for further details.

Note: Data published herein is intended as a guide only and shall not be construed to warrant applicability for lifting purposes.
Crane operation is subject to the computer charts and operation manual both supplied with the crane.

TECHNICAL DESCRIPTION

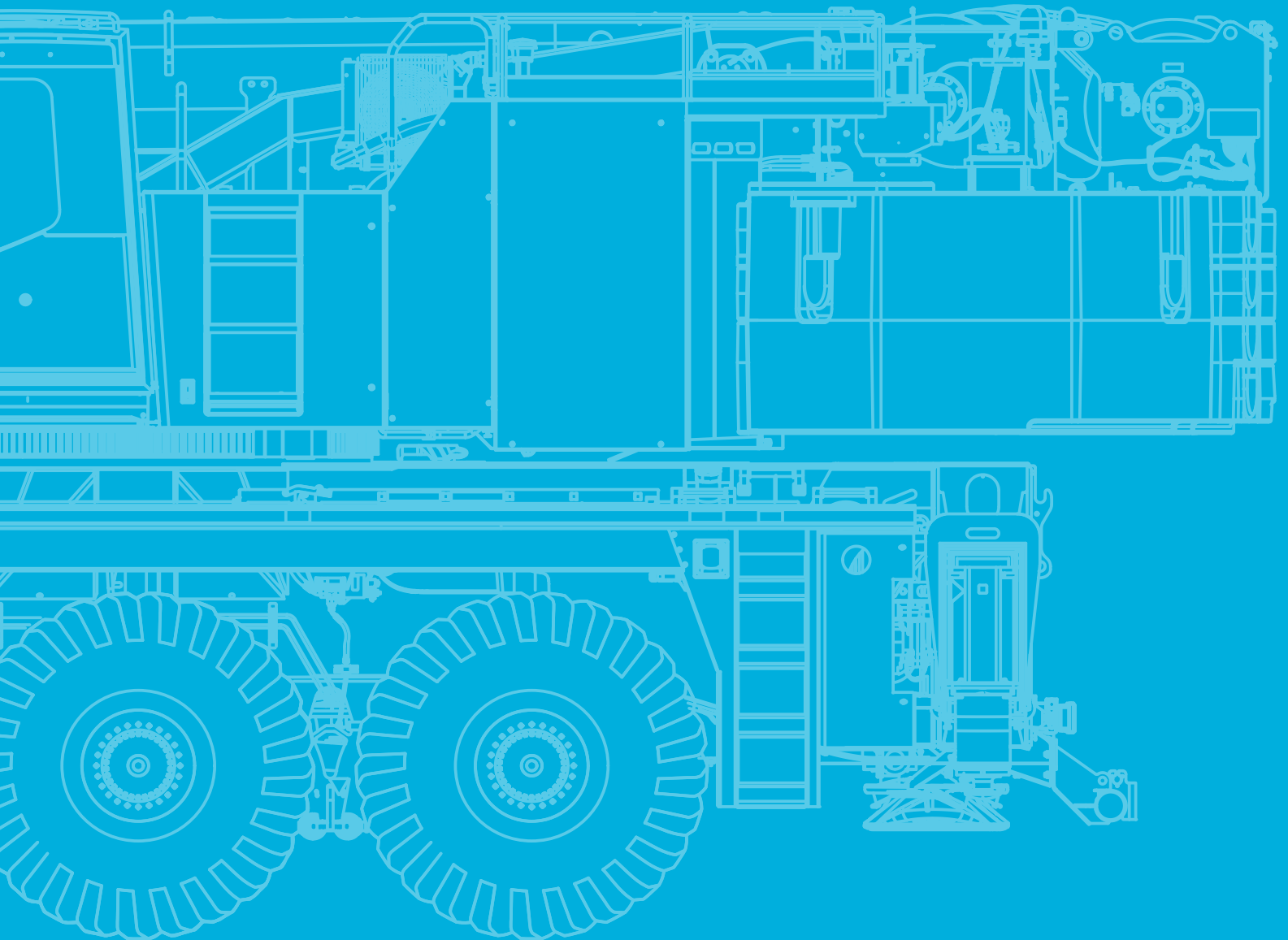

Technical Description

Basic machine

Equipment carrier

Engine 390-5	Mercedes-Benz OM471LA; Diesel engine; Output 390 kW/1600 1/min (530 HP), torque 2600 Nm /1300 1/min; The engine complies with EU Stage V/Tier 4F; Exhaust system complete stainless steel with SCR catalyzer.
Fuel tank	159 gallons Diesel (no RME / biodiesel); 11 gallons Ad-Blue tank.
Transmission ZF TraXon	Automated gearbox with 12 forward speeds and 2 reverse; 2-stage transfer case with switchable longitudinal lock.
Axles 10 x 8 x 10	All 5 axles steered, axles 1, 2, 4, 5 driven and equipped with selectable transverse lock.
Suspension	Hydropneumatic suspension with axle load compensation; Hydraulically lockable; Manual or automatic levelling alternatively.
Steering	Dual circuit hydro servocom steering with emergency steering pump; Active rear axle steering.
Brakes	Pneumatic dual circuit service brake with antilock system, acting on all wheels; Disc brakes; Additional, double-speed decompression brake; Spring-loaded parking brake.
Tires	Tires size 385/95 R25 (14.00R25); Steel rim 9,5-25/1,7"
Cab 2690	Type 8.8 ft; Adjustable driver seat, armrests and pneumatic suspension; Height and tilt-adjustable steering wheel; Auxiliary/passenger seat; Powered door windows; Tinted glass; Radio; Seat heating; Heating engine-dependent; Aircondition.
Rear view camera	Display in carrier cab; Cameras installed on rear of vehicle.
Drive lights	Including low beam, upper beam, daytime running lights, fog lights and cornering lights.
Central lubrication	Automatic central lubrication system for the lubricating points at the carrier.
Outriggers	H-4-Point design; Vertical and horizontal movement fully hydraulic; Manual or automatic levelling alternatively; 5 outrigger bases: 8.9 ft, 15.1 ft, 18.4 ft, 23.0 ft and 27.2 ft. 4 square outrigger pads with transport position at vertical cylinder.
Outrigger basis monitoring	Individual monitoring of horizontal stroke; Deviation warning in crane cab.
Outrigger load indicator	The outrigger load is indicated in the operator cab and the outrigger control box.
Electronic immobiliser system	Prevents uncontrolled carrier mobilisation; Incl. 4 ignition keys.
Pneumatic tire filling plug	For self-filling of the wheels.

Equipment superstructure

Engine 150-5	Mercedes-Benz OM934LA; Diesel engine; Output 150 kW / 1800 1/min (204 HP), torque 850 Nm / 1200-1600 1/min; The engine complies with EU Stage V/Tier 4F; Exhaust system complete stainless steel with SCR catalyzer.
Telescopic boom HA68	43.3 ft - 223.1 ft; Single cylinder telescoping system, automatic telescoping; Attachments for all equipment and extensions; 7 sheaves integrated in boom head for max. capacity of 293,300 lbs.
Boom luffing	1 luffing cylinder with automatic lowering brake valve.
Rotary drive	Single slewing gear unit with spring-loaded multi-disc brake.
H1	Hoist with spring-loaded multi-disc brake; Resolver (hoist rotation indicator).
Counterweight 156,500 lbs	7 pieces (① – ⑦).
Control system	Enabling 4 simultaneous working movements; Electric pilot controls via 2 two-axis joysticks; Different control modes selectable for hydraulic circuits.
Operator aids	AML-F, with integrated electronic load moment indicator in accordance with EN13000; Color display; Displaying of current operating conditions, load charts, fault indicator; Signal lights indicating LMI-load; Crane data logger.
SmartChart	Smart crane control system for main boom and rooster sheave operation enabling higher lifting capacities especially over outriggers. Enables safe use of the full capacity of the crane even in asymmetric outrigger configurations. Visualization of full working area in operator cabin. In-cab lift simulation.
Hello-Net	Tadano telematic system.
Working range limiter	Displaying and programmability of the work range limits by AML-F.
Lift adjuster	Safety device which prevents the load from swinging out when the load is picked up and the released hook block from swinging when the load is set down; Activated by switch in operator cabin.
Cab 872	Type 2.86 ft; 12° tiltable seat incl. control panel; Fold-out front window; Extendable side pedestal, front pedestal; Handrails; Tinted safety glass; Pull-down sun visor; Radio; Seat heating; Heating engine-dependent and engine-independent; Aircondition.
Central lubrication	Automatic central lubrication system for the lubricating points at the superstructure.

Technical Description

Additional equipment

Carrier

Axles 10 x 6 x 10	All 5 axles steered, axles 1, 2, 4, 5 driven and equipped with selectable transverse lock.
Wear-free auxiliary brake	Wear-free auxiliary eddy-current brake at 4th axle.
Tires	10 tires; Tire size 445/95R25 (16.00R25) or 525/80 (20.5R25).

Superstructure

Heavy lift attachment	2 additional sheaves; Dis-/connectable; For total 6 sheaves at boom head; Max. capacity 392,200 lbs.
2. hoist (H2)	Spring-loaded multi-disc brake; Integrated resolver (hoist rotation indicator); Quick couplings; Incl. hoist monitoring.
Load supervision camera	Camera mounted on main boom head to supervise the hook block and load from above; Incl. boom head light on boom head.

Handling

Remote control	Control of superstructure movements via wireless remote control.
-----------------------	--

Extensions

FJ 3.6 ft + 15.4 ft	Folding swing-away jib, manual offset 20°/40°; 3-sheaves head; Incl. transport storage.
FJ 3.6 ft + 35.8 ft	Folding swing-away jib, manual offset 20°/40°; 1-sheave head; Incl. transport storage.
FJ 19.7 ft inserts	Up to 4 x 19.7 ft intermediate section for usage with FJ.
FJ hydraulic	Hydraulic, stepless offset 0°-40°, instead of the manual offset; Available for FJ 3.6 ft + 15.4 ft – FJ 3.6 ft + 114.5 ft.
HTLJ 6.2 ft + 68.6 ft	Hydraulically telescopable and offsetable main boom extension; Length 6.2 ft + 27.9 ft – 6.2 ft + 68.6 ft; Hydraulic offset 5°-60°.
FJ (runner)	1.3 ft + 3.9 ft; Variable assembly jib with manual offset; 1-sheave, for max. 43,400 lbs lifting capacity.

Hook Blocks

Hook block 441,000 lbs 9-sheaves	Max. capacity 392,200 lbs; 3,530 lbs; Double hook, red with white signal stripes.
Hook block 352,800 lbs 7-sheaves	Max. capacity 313,300 lbs; 2,870 lbs; Double hook, red with white signal stripes.
Hook block 275,600 lbs, 5-sheaves	Max. capacity 232,400 lbs; 2,540 lbs; Double hook, red with white signal stripes.
Hook block 176,400 lbs, 3-sheaves	Max. capacity 149,700 lbs; 1,760 lbs; Double hook, red with white signal stripes.
Hook block 70,500 lbs, 1-sheave	Max. capacity 64,800 lbs; 990 lbs; Single hook, red with white signal stripes.
Hook 22,050 lbs	Max. capacity 22,050 lbs; 660 lbs; Single hook, red.

Further additional equipment on request!

Weight data may deviate from posted values based on road / travel configuration, equipment configuration, and component weight tolerances.

fac.sales@tadano.com
www.tadanoamericas.com

Tadano Europe Holdings GmbH

Dinglerstraße 24, 66482 Zweibrücken, Germany
Phone +49 6332 830

Tadano America Corporation

4242 West Greens Road, Houston, TX 77066
Phone: +1 (281) 869-00300 · Fax: +1 (281) 869-0040



Lifting your dreams



TADANO
MAXIM
Crane Works, L.P.
1-877-MAX-LIFT