



1-877-MAX-LIFT

GR-550XL-2

55 Ton Capacity (50.0 Metric Tons)

HYDRAULIC ROUGH TERRAIN CRANE

DIMENSIONS

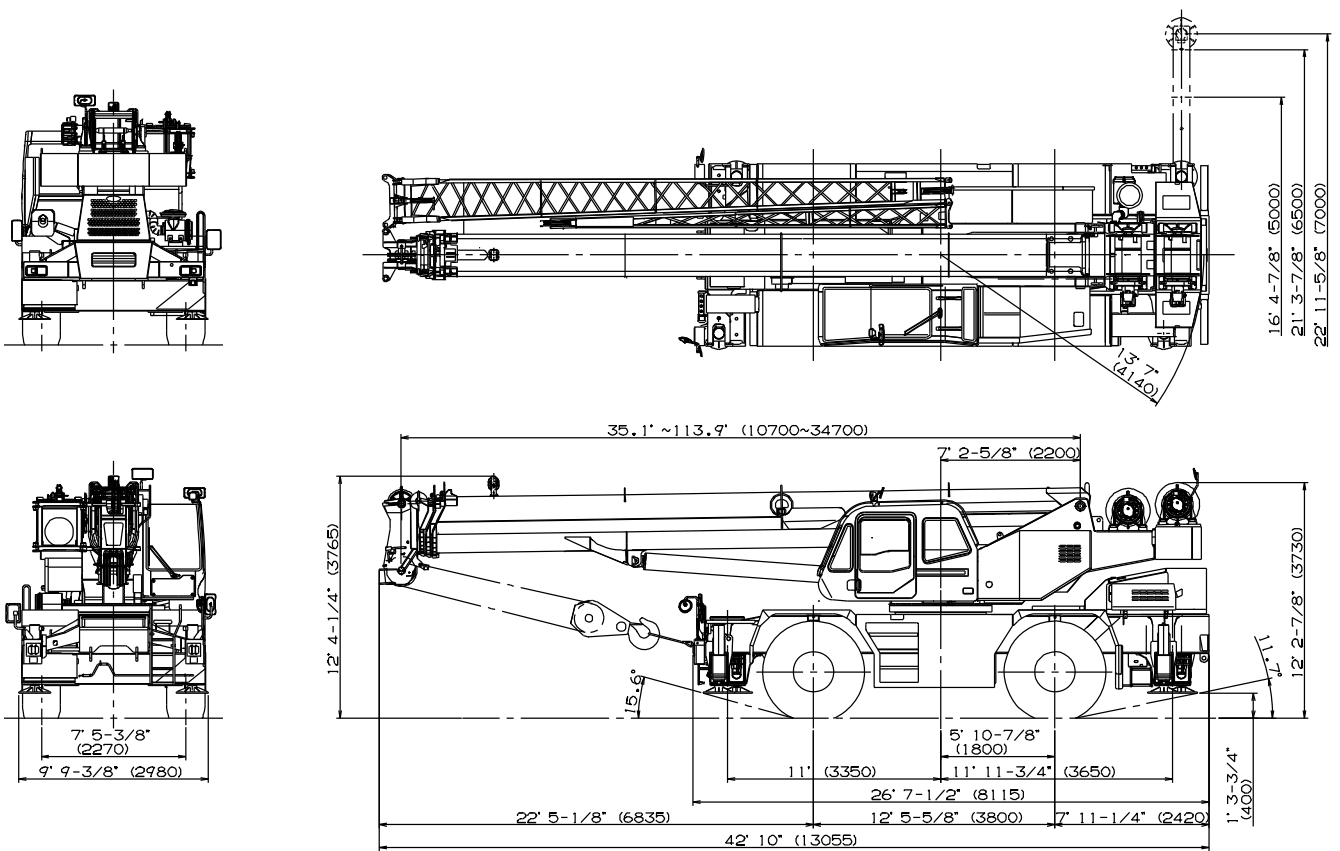

Note : Dimension is with boom angle at -0.8 degree.

() Reference dimensions in mm.

GENERAL DIMENSIONS (23.5 - 25 Tires)

	Feet	Meters
Turning radius		
4 wheel steer	22'	6.7
2 wheel steer	38' 5"	11.7

Specifications are subject to change without notice.

CRANE SPECIFICATIONS

BOOM

Four section full power synchronized telescoping boom, 35.1'~113.9' (10.7m~34.7m), of round box construction with four sheaves, 17-5/16" (0.44m) root diameter, at boom head. The synchronization system consists of telescope cylinder, two extension cables and retraction cables. Hydraulic cylinder fitted with holding valve. Two easily removable wire rope guards, rope dead end provided on both sides of boom head. Boom telescope sections are supported by wear pads both vertically and horizontally. Extension speed 78.8' in 72 seconds.

BOOM ELEVATION - By a double acting hydraulic cylinder with holding valve. Elevation -0.8°~81°, combination controls for hand or foot operation. Boom angle indicator. Automatic speed reduction and slow stop function. Elevating speed 20°~60° in 27 seconds.

JIB - Two stage bi-fold lattice type, 5°, 25° or 45° offset (tilt type). Single sheave, 15-5/8" (0.396m) root diameter, at the head of both jib sections. Stored alongside base boom section. Jib length is 28.9' (8.8m) or 50' (15.2m). Assistant cylinders for mounting and stowing, controlled at right side of superstructure. Self stowing jib mounting pins.

AUXILIARY LIFTING SHEAVE (SINGLE TOP)
Single sheave, 15-5/8" (0.396m) root diameter. Mounted to main boom head for single line work (stowable).

ANTI-TWO BLOCK - Pendant type over-winding cut out device with audio-visual (FAILURE lamp/BUZZER) warning system.

SWING
Hydraulic axial piston motor through planetary swing speed reducer. Continuous 360° full circle swing on ball bearing turn table at 2.7min⁻¹{rpm}. Equipped with manually locked/released swing brake. A 360° positive swing lock for pick and carry and travel modes, manually engaged in cab. Twin swing system: Free swing or lock swing controlled by selector switch on front console.

HOIST

MAIN HOIST - Variable speed type with grooved drum driven by hydraulic axial piston motor through speed reducer. Power load lowering and raising. Equipped with automatic brake (neutral brake) and counterbalance valve. Controlled independently of auxiliary hoist. Equipped with cable follower and drum rotation indicator.

DRUM - Grooved 15-3/4" (0.40m) root diameter x 23-9/16" (0.599m) wide. Wire rope: 633' of 3/4" diameter rope (193m of 19mm). Drum capacity: 1,074' (327.5m) 7 layers. Maximum single line pull: 1st layer 15,200 lbs (6,880kg). Maximum permissible line pull wire strength: 15,600 lbs (7,085kg).

AUXILIARY HOIST - Variable speed type with grooved drum driven by hydraulic axial piston motor through speed reducer. Power load lowering and raising. Equipped with automatic brake (neutral brake) and counterbalance valve. Controlled independently of main hoist. Equipped with cable follower and drum rotation indicator.

DRUM - Grooved 15-3/4" (0.40m) root diameter x 23-9/16" (0.599m) wide. Wire rope: 361' of 3/4" diameter rope (110m of 19mm). Drum capacity: 1,074' (327.5m) 7 layers. Maximum single line pull: 1st layer 15,200 lbs (6,880kg). Maximum permissible line pull wire strength: 15,600 lbs (7,085kg).

WIRE ROPE - Warrington seal wire, extra improved plow steel, preformed, independent wire rope core, right regular lay. 3/4" (19 mm) 6X31 class

HOOK BLOCKS

55 ton (50.0 metric ton) - 5 sheaves with swivel hook and safety latch, for 3/4" (19mm) wire rope. (OPTIONAL)
6.2 ton (5.6 metric ton) - Weighted hook with swivel and Automatic Speed Reduction and Slow Stop function

HYDRAULIC SYSTEM

PUMPS - Two variable piston pumps for crane functions. Tandem gear pump for steering, swing and optional equipment. Powered by carrier engine. Pump disconnect for crane is engaged/ disengaged by rotary switch from operator's cab.

CONTROL VALVES - Multiple valves actuated by pilot pressure with integral pressure relief valves.

RESERVOIR - 148 gallon (560 lit.) capacity. External sight level gauge.

FILTRATION - BETA10=10 return filter, full flow with bypass protection, located inside of hydraulic reservoir. Accessible for easy replacement.

OIL COOLER - Air cooled fan type.

CAB AND CONTROLS

Both crane and drive operations can be performed from one cab mounted on rotating superstructure.

Left side, 1 man type, steel construction with sliding door access and safety glass windows opening at side. Door window is powered control. Windshield glass window and roof glass window are shatter-resistant. Tilt-telescoping steering wheel. Adjustable control lever stands for swing, boom elevating, boom telescoping, auxiliary hoist and main hoist. Control lever stands can change neutral positions and tilt for easy access to cab. 3 way adjustable operator's seat with high back, headrest and armrest. Engine throttle knob. Foot operated controls: boom elevating, boom telescoping, service brake and engine throttle. Hot water cab heater and air conditioning.

Dash-mounted engine start/stop, monitor lamps, cigarette lighter, drive selector switch, parking brake switch, steering mode select switch, power window switch, pump engaged/ disengaged switch, swing brake switch, telescoping / auxiliary hoist select switch, outrigger controls, free swing / lock swing selector switch, eco mode switch, and ashtray.

Instruments - Torque converter oil temperature, engine water temperature, air pressure, fuel, speedometer, tachometer, hour meter and odometer / tripmeter. Hydraulic oil pressure is monitored and displayed on the AML-C display panel.

Tadano electronic LOAD MOMENT INDICATOR system (AML-C) including:

- Control lever lockout function with audible and visual pre-warning
- Boom position indicator
- Outrigger state indicator
- Boom angle / boom length / jib offset angle / jib length / load radius / rated lifting capacities / actual loads read out
- Ratio of actual load moment to rated load moment indication
- Automatic Speed Reduction and Slow Stop function on boom elevation and swing
- Working condition register switch
- Load radius / boom angle / tip height / swing range preset function
- External warning lamp
- Tare function
- Fuel consumption monitor
- Main hoist / auxiliary hoist select
- Drum rotation indicator (audible and visible type) main and auxiliary hoist

TADANO AML-C monitors outrigger extended length and automatically programs the corresponding "RATED LIFTING CAPACITIES" table

Operator's right hand console includes transmission gear selector and sight level bubble. Upper console includes working light switch, roof washer and wiper switch emergency outrigger set up key switch, jib equipped/removed select switch, eco mode switch, and air conditioning control switch. Swing lock lever.

NOTE: Each crane motion speed is based on unladen conditions.

CARRIER SPECIFICATIONS

TYPE - Rear engine, left hand steering, driving axle 2-way selected type by manual switch, 4x2 front drive, 4x4 front and rear drive.

FRAME - High tensile steel, all welded mono-box construction.

TRANSMISSION - Electronically controlled full automatic transmission. Torque converter driving full powershift with driving axle selector. 6 forward and 2 reverse speeds, constant mesh.

SUSPENSION - Front: Semi-elliptic leaf springs with hydraulic lockout device. Rear: Semi-elliptic leaf springs with hydraulic lockout device.

BRAKE SYSTEMS - Service: Air over hydraulic disc brakes on all 4 wheels. Parking/Emergency: Spring applied-air released brake acting on input shaft of front axle. Auxiliary: Electro-pneumatic operated exhaust brake.

TIRES - 23.5-25(OR)

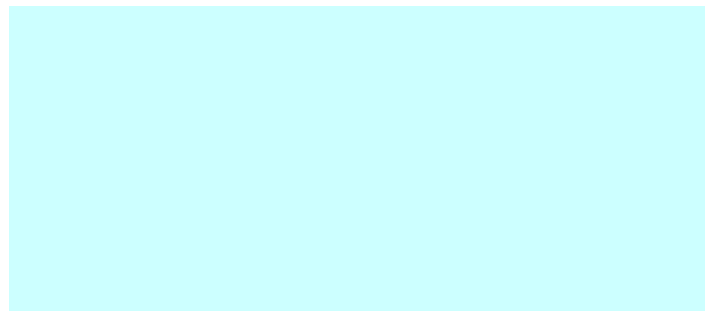
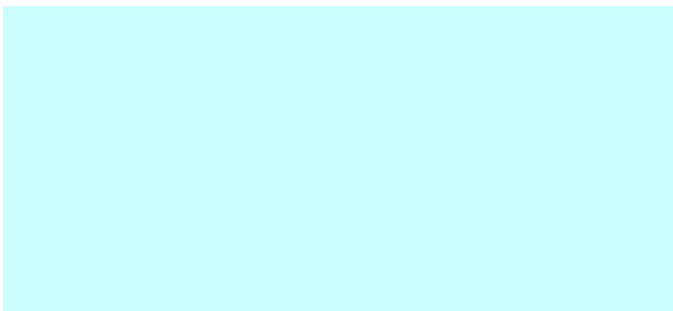

STANDARD EQUIPMENT

- Four section full power synchronized boom
35.1'~113.9' (10.7 m~34.7 m)
 - 28.9' or 50' (8.8 m or 15.2 m) bi-fold lattice jib (tilt type)
with 5°, 25° or 45° pinned offsets and self storing pins.
 - Quick reeving type bi-fold jib
 - Anti-Two block device (overwind cutout)
 - Mirror for main and auxiliary hoists
 - Work lights
 - Variable speed main hoist with grooved drum, cable follower
and 633' of 3/4" cable.
 - Variable speed auxiliary hoist with grooved drum, cable
follower and 361' of 3/4" cable.
 - Drum rotation indicator (audible, visible and thumper type) main
and auxiliary hoist
 - Auxiliary lifting sheave (single top) stowable
 - 6.2 ton (5.6 metric ton) hook with swivel
 - Tadano twin swing system and 360° positive swing lock
 - Positive control
 - Hydraulic oil cooler
 - 3 way adjustable cloth seat with armrests, high back
and seat belt
 - Tilt-telescoping steering wheel
 - Tinted safety glass and sun visor
 - Front windshield wiper and washer
 - Roof window wiper and washer
 - Power window (cab door)
 - Cigarette lighter and ashtray
 - Cab floor mat
 - Pump disconnect in operator's cab
 - Air conditioner (hot water heater and cooler)
 - Full instrumentation package
 - Self centering finger control levers with pilot control
 - Control pedals for boom elevating and boom telescoping
 - Low oil pressure/high water temp. warning device (visual)
 - Rear steer centering light
 - Air cleaner dust indicator
- Tadano electronic load moment indicator system (AML-C)
 - Boom angle indicator
 - Outrigger extension length detector
 - Electronic crane monitoring system
 - Rear view mirrors (right and left side)
 - Fenders
 - Air dryer
 - Complete highway light package
 - Towing hooks-Front and rear
 - Hook block tie down (front bumper)
 - Weighted hook storage compartment
 - Halogen head lamp
 - Independently controlled outriggers
 - Four outrigger extension positions
 - Self-storing outrigger pads
 - Electronic controlled automatic transmission driven
by torque converter
 - 4 X 4 X 4 drive/steer
 - Non-spin rear differential
 - Semi-elliptic leaf springs suspension with hydraulic lockout
device (front and rear)
 - 23.5-25 (OR) tires
 - Disc brakes
 - Water separator with filter(high filtration)
 - Back-up alarm
 - 24 volt electric system
 - Tool storage compartment
 - Tire inflation kit
 - Mitsubishi 6M60-TLA3B turbo charged after cooled engine
(267HP) with exhaust brake
 - Engine over-run alarm
 - Lifting eyes
 - Telematics(machine data logging and monitoring system)
with HELLO-NET via internet
(availability depends on countries)
 - Fuel consumption monitor
 - Eco mode system
- 55 ton (50.0 metric ton) - 5 sheave with swivel hook and
safety latch for 3/4"(19mm) wire rope

LINE SPEEDS AND PULLS

Layer	Line speeds ¹		Line pulls Available ²	
	F.P.M	m/min	Lbs.	kgf
2nd	358	109	15,200	6,880
	387	118	13,900	6,310
	417	127	12,800	5,820
	446	136	11,900	5,410
	475	144	11,100	5,050
6th	504	153	10,400	4,730
7th ³	533	162	9,800	4,460

- Maximum permissible line pull wire strength
15,600lbs(7,085kg) with 6X31 class rope.

¹ Line speeds based only on hook block, not loaded.

² Developed by machinery with each layer of wire rope, but not based
on rope strength or other limitation in machinery or equipment.

³ Seventh layer of wire rope are not recommended
for hoisting operations.

DRUM WIRE ROPE CAPACITIES

	Feet		Meters	
	Feet	Meters	Feet	Meters
1	123.3	37.6	123.3	37.6
	133.5	40.7	256.8	78.3
	143.3	43.7	400.2	122.0
	153.5	46.8	553.8	168.8
	163.3	49.8	717.1	218.6
7	173.8	53.0	891.0	271.6
	183.3	55.9	1074.4	327.5

DRUM DIMENSIONS

	Inch	mm
	15-3/4"	400
	23-9/16"	599
	27-3/8"	695

GR-550XL WORKING RANGE CHART

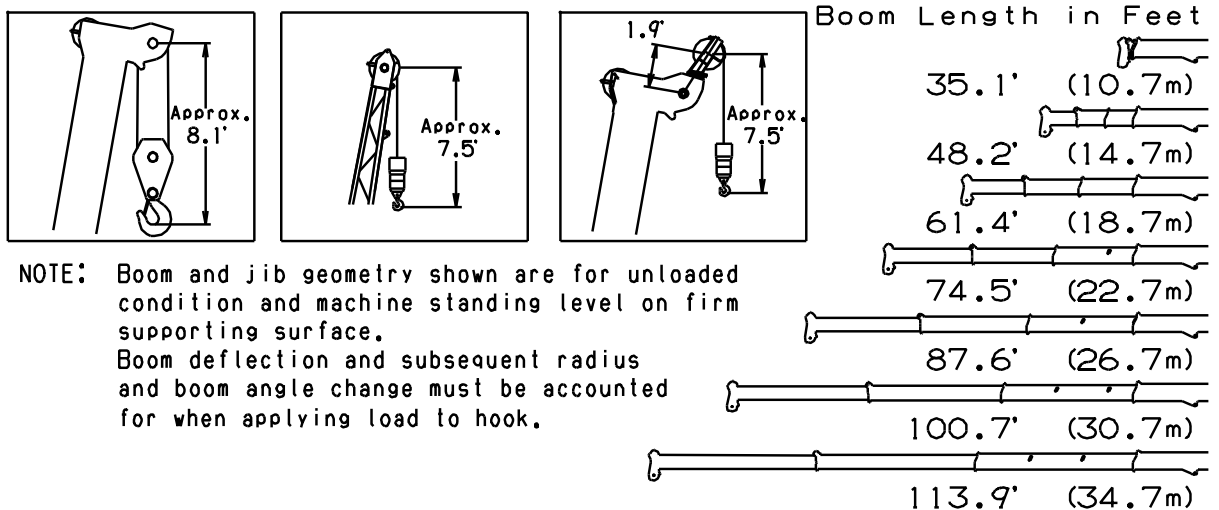
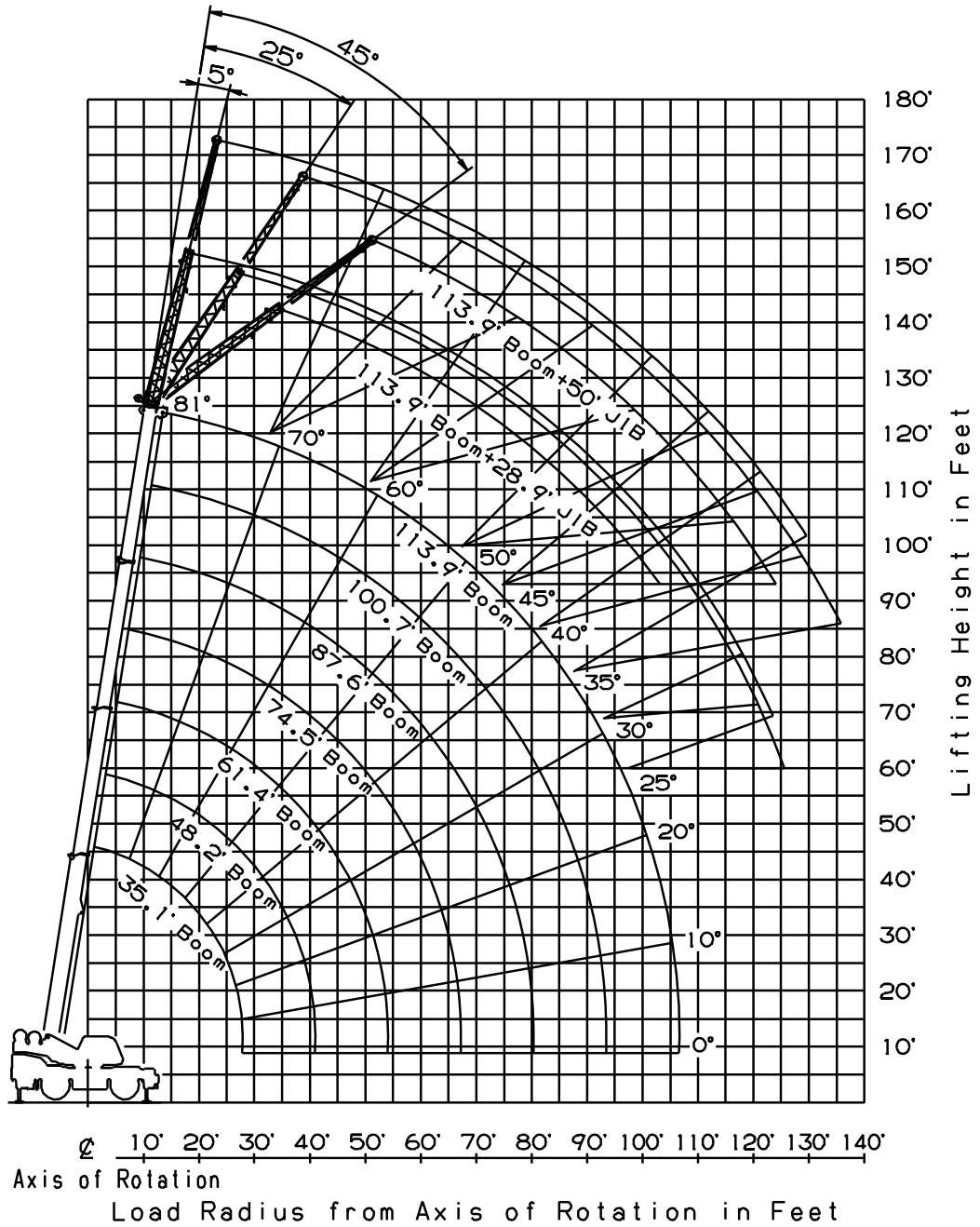

GR-550XL RATED LIFTING CAPACITIES (IN POUNDS)

ON OUTRIGGERS FULLY EXTENDED 22' 11-5/8"(7.0m) SPREAD														
360° ROTATION														
B \ A	35.1		48.2		61.4		74.5		87.6		100.7		113.9	
	C	(10.7m)	C	(14.7m)	C	(18.7m)	C	(22.7m)	C	(26.7m)	C	(30.7m)	C	(34.7m)
8	70	110,000												
10	66	100,600	73	46,700	77	46,700	80	44,300						
12	63	87,900	70	46,700	75	46,700	78	44,300	81	41,200				
15	56	73,400	67	46,700	72	46,700	76	44,300	79	40,300	81	33,000		
20	44	54,400	60	46,700	67	46,700	72	42,100	76	35,800	78	30,500	80	25,100
25	27	38,500	52	43,000	62	43,000	68	39,500	72	31,700	75	27,300	78	23,900
30			44	33,800	56	35,000	64	35,500	69	28,700	72	25,000	75	21,600
35			33	25,600	50	26,600	59	27,000	65	25,300	69	23,000	72	19,900
40			16	20,400	44	21,100	54	21,500	61	21,200	66	20,500	70	19,000
45					36	17,100	49	17,300	57	17,500	63	17,400	67	17,100
50					25	14,100	43	14,300	53	14,500	59	14,400	64	14,500
55							37	12,000	48	12,200	56	12,100	61	12,200
60							29	10,200	43	10,300	52	10,300	58	10,350
65							18	8,700	38	8,750	48	8,850	54	8,850
70									32	7,550	44	7,600	51	7,650
75									24	6,550	39	6,600	47	6,650
80									9	5,700	34	5,700	44	5,750
85											27	4,950	39	5,000
90											19	4,350	35	4,350
95													30	3,750
100													23	3,250
105													13	2,350
D														0

LIFTING CAPACITIES AT ZERO DEGREE BOOM ANGLE ON OUTRIGGERS FULLY EXTENDED														
22' 11-5/8"(7.0m) SPREAD 360° ROTATION														
C \ A	35.1		48.2		61.4		74.5		87.6		100.7		113.9	
	B	(10.7m)	B	(14.7m)	B	(18.7m)	B	(22.7m)	B	(26.7m)	B	(30.7m)	B	(34.7m)
0	27.8	16,500	41.0	10,600	54.1	7,000	67.3	4,800	80.2	3,300	92.7	2,200	105.4	1,400

ON OUTRIGGERS MID EXTENDED 21' 3-7/8"(6.5m) SPREAD														
360° ROTATION														
B \ A	35.1		48.2		61.4		74.5		87.6		100.7		113.9	
	C	(10.7m)	C	(14.7m)	C	(18.7m)	C	(22.7m)	C	(26.7m)	C	(30.7m)	C	(34.7m)
8	70	110,000												
10	66	100,600	73	46,700	77	46,700	80	44,300						
12	63	87,900	70	46,700	75	46,700	78	44,300	81	41,200				
15	56	73,400	67	46,700	72	46,700	76	44,300	79	40,300	81	33,000		
20	44	54,400	60	46,700	67	46,700	72	42,100	76	35,800	78	30,500	80	25,100
25	27	38,500	52	40,600	62	41,300	68	39,500	72	31,700	75	27,300	78	23,900
30			44	28,300	56	29,000	64	29,500	69	28,700	72	25,000	75	21,600
35			33	21,000	50	21,600	59	22,100	65	22,400	69	22,500	72	19,900
40			16	16,300	43	17,000	54	17,300	61	17,500	66	17,600	70	17,700
45					35	13,700	49	14,000	57	14,100	62	14,300	67	14,200
50					25	11,100	43	11,500	53	11,700	59	11,800	64	11,700
55							37	9,500	48	9,700	55	9,900	60	9,800
60							29	8,000	43	8,200	52	8,300	57	8,200
65							18	6,500	38	7,000	48	7,000	54	7,000
70									32	5,900	43	5,900	50	6,000
75									24	5,000	39	5,000	47	5,100
80									9	4,000	33	4,300	43	4,400
85											27	3,700	39	3,700
90											19	2,900	35	3,100
95													29	2,700
100													23	2,200
105													12	1,650
D														0

LIFTING CAPACITIES AT ZERO DEGREE BOOM ANGLE ON OUTRIGGERS MID EXTENDED														
21' 3-7/8"(6.5m) SPREAD 360° ROTATION														
C \ A	35.1		48.2		61.4		74.5		87.6		100.7		113.9	
	B	(10.7m)	B	(14.7m)	B	(18.7m)	B	(22.7m)	B	(26.7m)	B	(30.7m)	B	(34.7m)
0	27.8	16,500	41.0	10,600	54.1	7,000	67.3	4,800	80.2	3,300	92.7	2,200	105.4	1,400

- A : Boom length in feet
- B : Load radius in feet
- C : Loaded boom angle (°)
- D : Minimum boom angle (°) for indicated length (no load)

NOTE: The lifting capacity data stored in the LOAD MOMENT INDICATOR (AML-C) is based on the standard number of parts of line listed in the chart. Standard number of parts of line for each boom length should be according to the following table.

Boom length in feet (meters)	35.1' (10.7m)	35.1' to 61.4' (10.7m to 18.7m)	61.4' to 113.9' (18.7m to 34.7m)	Single top Jib
Number of parts of line	10	6	4	1

GR-550XL RATED LIFTING CAPACITIES (IN POUNDS)

B	A		C	(14.7m)	C	(18.7m)	C	(22.7m)	C	(26.7m)	100.7		C	(34.7m)
	C	(10.7m)									C	(30.7m)		
8	70	110,000												
10	66	100,600	73	46,700	77	46,700	80	44,300						
12	63	87,900	70	46,700	75	46,700	78	44,300	81	41,200				
15	56	72,400	67	46,700	72	46,700	76	44,300	79	40,300	81	33,000		
20	44	38,500	60	39,900	67	40,700	72	41,400	76	35,800	78	30,500	80	25,100
25	27	24,600	52	26,000	62	26,600	68	27,200	72	27,500	75	27,200	78	23,900
30			44	18,600	56	19,000	63	19,500	68	19,800	72	19,900	75	19,600
35			33	13,700	50	14,400	59	14,800	65	15,000	69	15,000	72	15,100
40			16	10,400	43	11,200	54	11,700	61	11,900	65	11,900	69	11,900
45					35	8,800	49	9,300	57	9,500	62	9,500	66	9,600
50					25	7,000	43	7,500	53	7,700	59	7,700	63	7,800
55							37	6,000	48	6,150	55	6,150	60	6,300
60							29	4,850	43	5,000	51	5,000	57	5,100
65							18	3,700	38	4,050	47	4,050	54	4,150
70									32	3,300	43	3,300	50	3,400
75									24	2,650	38	2,700	47	2,800
80									9	2,000	33	2,100	43	2,200
85											27	1,600	39	1,700
90											18	1,050	34	1,300

LIFTING CAPACITIES AT ZERO DEGREE BOOM ANGLE ON OUTRIGGERS MID EXTENDED

16' 4-7/8" (5.0m) SPREAD 360° ROTATION

C	A		B	(14.7m)	B	(18.7m)	B	(22.7m)	B	(26.7m)	B	(30.7m)
	B	(10.7m)										
0	27.8	16,500	41.0	9,900	54.1	5,670	67.3	3,480	80.2	1,980	92.7	900

ON OUTRIGGERS MIN EXTENDED 8' 1-5/8" (2.48m) SPREAD

360° ROTATION

B	A		C	(14.7m)	C	(18.7m)	C	(22.7m)	C	(26.7m)	C	(30.7m)	C	(34.7m)
	C	(10.7m)												
8	70	75,800												
10	66	48,500	73	46,700	77	46,700	80	44,300						
12	62	34,100	70	35,900	75	35,700	78	34,900	80	33,600				
15	56	22,600	67	24,100	72	24,800	76	24,700	78	23,900	80	23,000		
20	45	13,000	60	14,300	67	14,900	72	15,400	75	15,100	77	14,600	79	13,900
25	29	8,050	52	9,200	62	9,700	67	10,200	71	10,400	74	10,000	76	9,500
30			44	6,100	56	6,600	63	7,000	68	7,200	71	7,000	74	6,700
35			33	3,900	50	4,400	59	4,800	64	5,000	68	5,000	71	4,700
40			17	2,500	43	2,900	54	3,300	60	3,500	65	3,500	68	3,300
45					35	1,800	49	2,100	56	2,300	61	2,400	65	2,200
50							43	1,200	52	1,400	58	1,500	62	1,400

LIFTING CAPACITIES AT ZERO DEGREE BOOM ANGLE ON OUTRIGGERS MIN EXTENDED

8' 1-5/8" (2.48m) SPREAD 360° ROTATION

C	A		B	(14.7m)
	B	(10.7m)		
0	27.8	6,040	41.0	2,120

- A : Boom length in feet
- B : Load radius in feet
- C : Loaded boom angle (°)
- D : Minimum boom angle (°) for indicated length (no load)

NOTE: The lifting capacity data stored in the LOAD MOMENT INDICATOR (AML-C) is based on the standard number of parts of line listed in the chart. Standard number of parts of line for each boom length should be according to the following table.

Boom length in feet (meters)	35.1' (10.7m)	35.1' to 61.4' (10.7m to 18.7m)	61.4' to 113.9' (18.7m to 34.7m)	Single top Jib
Number of parts of line	10	6	4	1

GR-550XL RATED LIFTING CAPACITIES (IN POUNDS)

ON OUTRIGGERS FULLY EXTENDED 22' 11-5/8"(7.0m) SPREAD 360° ROTATION													
C	113.9' (34.7m) Boom + 28.9' (8.8m) Jib						C	113.9' (34.7m) Boom + 50' (15.2m) Jib					
	5° Tilt		25° Tilt		45° Tilt			5° Tilt		25° Tilt		45° Tilt	
	R	W	R	W	R	W		R	W	R	W	R	W
80	25.6	12,300	34.8	8,400	41.5	6,050	80	32.6	6,350	47.6	4,050	59.0	2,750
77.5	32.9	12,000	41.3	8,000	47.3	5,900	77.5	40.8	6,200	54.9	3,900	65.3	2,700
75	39.8	11,500	47.5	7,650	53.1	5,700	75	48.6	6,050	61.9	3,700	71.6	2,600
72.5	46.3	10,600	53.6	7,350	58.7	5,550	72.5	56.0	5,600	68.5	3,550	77.5	2,550
70	52.3	9,750	59.5	7,100	64.0	5,400	70	63.0	5,200	75.0	3,350	83.2	2,500
67.5	58.3	9,100	65.1	6,850	69.2	5,300	67.5	69.6	4,900	81.2	3,200	88.7	2,450
65	64.0	8,500	70.5	6,600	74.0	5,200	65	76.1	4,600	87.0	3,100	93.9	2,400
62.5	69.4	7,900	75.6	6,400	78.9	5,100	62.5	82.2	4,350	92.6	3,000	98.9	2,350
60	74.8	7,400	80.5	6,200	83.7	5,050	60	88.4	4,150	98.1	2,900	103.8	2,350
57.5	79.5	6,500	85.5	5,700	88.2	5,000	57.5	94.4	3,950	103.6	2,800	108.4	2,300
55	84.0	5,650	90.0	5,200	92.5	4,950	55	100.0	3,800	108.7	2,700	112.6	2,300
52.5	88.8	5,000	94.1	4,600	96.2	4,450	52.5	105.4	3,500	113.3	2,650	116.7	2,250
50	93.1	4,400	98.2	4,100	99.7	3,950	50	110.2	3,150	117.9	2,600	120.3	2,250
47.5	97.4	3,950	102.1	3,700	103.3	3,550	47.5	114.8	2,750	121.9	2,400	124.0	2,200
45	101.4	3,500	105.6	3,300	106.6	3,150	45	119.3	2,400	125.7	2,150	127.1	2,100
42.5	105.3	3,150	109.1	2,950			42.5	123.3	2,100	129.3	1,900		
40	109.0	2,800	112.3	2,650			40	127.0	1,850	132.7	1,700		
37.5	112.6	2,500	115.5	2,400			37.5	131.1	1,600	135.7	1,500		
35	115.8	2,250	118.2	2,200			35	134.4	1,400	138.5	1,300		
32.5	118.7	2,050	120.9	2,000									
30	121.6	1,850	123.3	1,800									
27.5	124.1	1,700	125.3	1,650									
25	126.3	1,600	127.1	1,550									

C :Loaded boom angle (°)
R :Load radius in feet
W :Rated lifting capacity in pounds

GR-550XL RATED LIFTING CAPACITIES (IN POUNDS)

ON OUTRIGGERS MID EXTENDED 21' 3-7/8"(6.5m) SPREAD

360° ROTATION

C	113.9' (34.7m) Boom + 28.9' (8.8m) Jib						C	113.9' (34.7m) Boom + 50' (15.2m) Jib					
	5° Tilt		25° Tilt		45° Tilt			5° Tilt		25° Tilt		45° Tilt	
	R	W	R	W	R	W		R	W	R	W	R	W
80	25.6	12,300	34.8	8,400	41.5	6,050	80	32.6	6,350	47.6	4,050	59.0	2,750
77.5	32.9	12,000	41.3	8,000	47.3	5,900	77.5	40.8	6,200	54.9	3,900	65.3	2,700
75	39.8	11,500	47.5	7,650	53.1	5,700	75	48.6	6,050	61.9	3,700	71.6	2,600
72.5	46.3	10,600	53.6	7,350	58.7	5,550	72.5	56.0	5,600	68.5	3,550	77.5	2,550
70	52.3	9,750	59.5	7,100	64.0	5,450	70	63.0	5,200	75.0	3,350	83.2	2,500
67.5	58.1	8,800	65.1	6,850	69.2	5,300	67.5	69.6	4,900	81.2	3,200	88.7	2,450
65	63.5	7,900	70.5	6,600	74.0	5,200	65	76.1	4,600	87.0	3,100	93.9	2,400
62.5	68.7	6,800	75.3	5,800	78.9	4,950	62.5	82.2	4,350	92.6	3,000	98.9	2,350
60	73.6	5,800	79.9	5,050	83.5	4,700	60	88.3	4,100	98.1	2,900	103.8	2,350
57.5	78.5	5,100	84.6	4,450	87.8	4,250	57.5	93.8	3,550	103.5	2,700	108.4	2,300
55	83.3	4,500	89.0	3,850	91.8	3,850	55	99.0	3,000	108.4	2,500	112.6	2,300
52.5	87.9	3,900	93.4	3,300	95.7	3,350	52.5	104.0	2,450	112.9	2,150	116.4	2,000
50	92.5	3,300	97.4	2,850	99.3	2,900	50	108.8	2,000	117.1	1,800	119.9	1,750
47.5	96.7	2,800	101.4	2,450	102.9	2,450	47.5	113.6	1,700	121.2	1,500	123.4	1,450
45	100.7	2,350	105.0	2,100	106.2	2,050	45	118.0	1,400	124.9	1,200	126.4	1,150
42.5	104.3	2,000	108.5	1,800									
40	108.3	1,650	111.8	1,550									
37.5	111.7	1,400	115.0	1,300									
35	115.1	1,200	117.9	1,100									

ON OUTRIGGERS MID EXTENDED 16' 4-7/8"(5.0m) SPREAD

360° ROTATION

C	113.9' (34.7m) Boom + 28.9' (8.8m) Jib						C	113.9' (34.7m) Boom + 50' (15.2m) Jib					
	5° Tilt		25° Tilt		45° Tilt			5° Tilt		25° Tilt		45° Tilt	
	R	W	R	W	R	W		R	W	R	W	R	W
80	25.6	12,300	34.8	8,400	41.5	6,050	80	32.6	6,350	47.6	4,050	58.8	2,750
77.5	32.9	12,000	41.3	8,000	47.3	5,900	77.5	40.8	6,200	54.9	3,900	65.3	2,700
75	39.8	11,500	47.5	7,650	53.1	5,700	75	48.6	6,050	61.9	3,700	71.6	2,600
72.5	45.7	9,700	53.4	7,000	58.7	5,550	72.5	56.0	5,600	68.5	3,550	77.5	2,550
70	51.3	7,900	58.9	6,300	64.0	5,400	70	63.0	5,200	75.0	3,350	83.2	2,500
67.5	56.9	6,550	64.4	5,450	68.9	4,850	67.5	69.1	4,500	81.0	3,100	88.7	2,450
65	62.2	5,300	69.2	4,700	73.4	4,350	65	75.1	3,800	86.6	2,850	93.7	2,400
62.5	67.3	4,300	74.0	3,850	78.0	3,650	62.5	80.9	3,050	91.9	2,400	98.6	2,150
60	72.3	3,400	78.8	3,150	82.6	3,000	60	86.1	2,400	97.1	1,950	103.3	1,900
57.5	77.0	2,750	83.4	2,550	86.8	2,450	57.5	91.6	1,800	102.1	1,500	107.5	1,500
55	81.8	2,200	87.9	2,000	90.8	2,000	55	96.7	1,300	106.7	1,100	111.6	1,100
52.5	86.4	1,700	92.3	1,550	94.8	1,550							
50	91.0	1,300	96.4	1,150	98.5	1,200							

C :Loaded boom angle (°)

R :Load radius in feet

W :Rated lifting capacity in pounds

WARNING AND OPERATING INSTRUCTIONS FOR LIFTING CAPACITIES

GENERAL

1. RATED LIFTING CAPACITIES apply only to the machine as originally manufactured and normally equipped by TADANO LTD. Modifications to the machine or use of optional equipment other than that specified can result in a reduction of capacity.
2. Hydraulic cranes can be hazardous if improperly operated or maintained. Operation and maintenance of this machine must be in compliance with information in the **Operation and Maintenance Manual** supplied with the crane. If this manual is missing, order a replacement through the distributor.
3. The operator and other personnel associated with this machine shall fully acquaint themselves with the latest American National Standards Institute (ANSI) safety standards for cranes.

SET UP

1. Rated lifting capacities on the load chart are the maximum allowable crane capacities. They are based on the machine standing level on firm supporting surface under ideal job conditions. Depending on the nature of the supporting surface, it may be necessary to have structural supports under the outrigger floats or tires to spread the loads to a larger surface.
2. For outrigger operation, outriggers shall be properly extended with tires free of supporting surface before operating crane.

OPERATION

1. Rated lifting capacities have been tested to and meet minimum requirements of SAE J1063-Cantilevered Boom Crane Structures Method of Test.
2. Rated lifting capacities do not exceed 85 % of the tipping load on outriggers fully extended as determined by SAE J765-Crane Stability Test Code.
Rated lifting capacities for partially extended outriggers are determined from the formula, Rated Lifting Capacities = (Tipping Load - 0.1 x Tip Reaction)/1.25.
3. Rated lifting capacities above bold lines in the chart are based on crane strength and those below, on its stability. They are based on actual load radius increased by boom deflection.
4. The weight of handling device such as hook blocks, slings, etc., must be considered as part of the load and must be deducted from the lifting capacities.
5. Rated lifting capacities are based on freely suspended loads and make no allowance for such factors as the effect of wind, sudden stopping of loads, supporting surface conditions, inflation of tires, operating speeds, side loads, etc. Side pull on the boom or jib is extremely dangerous.
6. Rated lifting capacities do not account for wind on lifted load or boom. We recommend against working under the condition that the load is out of control due to a strong wind. During boom lift, consider that the rated lifting capacity is reduced by 50% when the wind speed is 20mph(9m/s) to 27mph(12m/s); reduced by 70% when the wind speed is 27mph(12m/s) to 31mph(14m/s). If the wind speed is 31mph(14m/s) or over, stop operation. During jib lift, stop operation if the wind speed is 20mph(9m/s).
7. Rated lifting capacities at load radius shall not be exceeded. Do not tip the crane to determine allowable loads.
8. Do not operate at boom lengths, radii, or boom angle, where no capacities are shown. Crane may overturn without any load on the hook.

9. When boom length is between values listed, refer to the rated lifting capacities of the next longer and next shorter booms for the same radius. The lesser of the two rated lifting capacities shall be used.
10. When making lifts at a load radius not shown, use the next longer radius to determine allowable capacity.
11. Load per line should not exceed 12,300 lbs. (5,600kg) for main hoist and auxiliary hoist.
12. Check the actual number of parts of line with LOAD MOMENT INDICATOR (AML-C) before operation. Maximum lifting capacity is restricted by the number of parts of line of LOAD MOMENT INDICATOR (AML-C). Limited capacity is as determined from the formula, Single line pull for main hoist 12,300 lbs.(5,600kg) x number of parts of line.
13. The boom angle before loading should be greater to account for deflection. For rated lifting capacities, the loaded boom angle and the load radius is for reference only.
14. The 35.1' (10.7m) boom length capacities are based on boom fully retracted. If not fully retracted [less than 48.2'(14.7m) boom length], use the rated lifting capacities for the 48.2' (14.7m) boom length.
15. Extension or retraction of the boom with loads may be attempted within the limits of the RATED LIFTING CAPACITIES. The ability to telescope loads is limited by hydraulic pressure, boom angle, boom length, crane maintenance, etc.
16. For lifting capacity of single top, reduce the rated lifting capacities of relevant boom according to a weight reductions for auxiliary load handling equipment. Capacities of single top shall not exceed 12,300 lbs. (5,600kg) including main hook.
17. When base jib or top jib or both jib removing, jib state switch select removed.
18. When erecting and stowing jib, be sure to retain it by hand or by other means to prevent its free movement.
19. Use "ANTI-TWO BLOCK" disable switch when erecting and stowing jib and when stowing hook block. While the switch is pushed, the hoist does not stop, even when overwind condition occurs.
20. For boom length with 28.9' (8.8m) jib, rated lifting capacities are determined by loaded boom angle only in the column headed "113.9' (34.7m) boom + 28.9' (8.8m) jib".
For boom length with 50' (15.2 m) jib, rated lifting capacities are determined by loaded boom angle only in the column headed "113.9' (34.7m) boom + 50' (15.2m) jib".
For angles not shown, use the next lower loaded boom angle to determine allowable capacity.
21. When lifting a load by using jib (aux. winch) and boom (main winch) simultaneously, do the following:
 - Enter the operation status as jib operation, not as boom operation.
 - Before starting operation, make sure that mass of load is within rated lifting capacity for jib.

DEFINITIONS

1. Load Radius: Horizontal distance from a projection of the axis of rotation to supporting surface before loading to the center of the vertical hoist line or tackle with load applied.
2. Loaded Boom Angle: The angle between the boom base section and the horizontal, after lifting the rated lifting capacity at the load radius.
3. Working Area: Area measured in a circular arc about the centerline of rotation.
4. Freely Suspended Load: Load hanging free with no direct external force applied except by the hoist line.
5. Side Load: Horizontal side force applied to the lifted load either on the ground or in the air.

(IN POUNDS)

ON RUBBER STATIONARY

		Over Front						360					
B	A	C (10.7m)		C (18.7m)		C (26.7m)		C (10.7m)		C (18.7m)		C (26.7m)	
	10	66	48,300						66	27,200			
12	62	41,800						62	22,500				
15	56	34,300	72	30,500				56	16,300	72	16,300		
20	45	26,000	67	23,300				45	9,200	67	10,700		
25	29	18,100	62	18,300	71	13,400	30	5,500	62	6,800	71	7,500	
30			56	13,900	68	11,000			56	4,600	68	5,000	
35			50	10,700	64	9,200			50	2,900	64	3,500	
40			43	8,300	60	7,900			43	1,800	60	2,200	
45			35	6,500	57	6,900			35	1,000	56	1,400	
50			25	5,100	52	5,500							
55					48	4,400							
60					43	3,600							
65					38	2,800							
70					31	2,200							
75					23	1,700							
80					9	1,300							
D													

LIFTING CAPACITIES AT ZERO DEGREE BOOM ANGLE ON RUBBER STATIONARY

		Over Front							
C	A	B (10.7m)		B (18.7m)		B (26.7m)		C (10.7m)	
	0	27.8	15,500	54.1	4,100	80.2	1,190	27.8	4,050

- A** : Boom length in feet
- B** : Load radius in feet
- C** : Loaded boom angle (°)
- D** : Minimum boom angle (°) for indicated length (no load)

B	A	C (10.7m)		C (18.7m)		C (26.7m)	
	10	66	35,600				
12	62	30,500					
15	56	24,700	72	26,000			
20	45	18,300	67	19,400			
25	29	13,900	62	15,200	71	13,400	
30			56	12,100	68	11,000	
35			50	9,600	64	9,200	
40			43	7,700	60	7,900	
45			35	6,200	57	6,900	
50			25	5,100	52	5,500	
55					48	4,400	
60					43	3,600	
65					38	2,800	
70					31	2,200	
75					23	1,700	
80					9	1,300	
D							

C	A	B (10.7m)		B (18.7m)		B (26.7m)	
	0	27.8	12,000	54.1	4,100	80.2	1,190

NOTE: The lifting capacity data stored in the LOAD MOMENT INDICATOR (AML-C) is based on the standard number of parts of line listed in the chart. Standard number of parts of line for on rubber operation should be according to the following table.

WARNING AND OPERATING INSTRUCTIONS FOR ON RUBBER LIFTING CAPACITIES

1. Rated lifting capacities on rubber are in pounds and do not exceed 75 % of tipping loads as determined by SAE J765-Crane Stability Test Code.
2. Rated lifting capacities shown in the chart are based on condition that crane is set on firm level surfaces with axle oscillation lockout applied. Those above bold lines are based on tire capacity and those below, on crane stability. They are based on actual load radius increased by tire deformation and boom deflection.
3. If the suspension lock cylinders contain air, the axle will not be locked completely and rated lifting capacities may not be obtainable. Bleed the cylinders according to the operation safety and maintenance manual.
4. Rated lifting capacities are based on proper tire inflation, capacity and condition. Damaged tires are hazardous to safe operation of
6. Over front operation shall be performed within two degrees in front of chassis.
7. On rubber lifting with "jib" is not permitted. Maximum permissible boom length is 87.6 ft. (26.7m).
8. When making lift on rubber stationary, set parking brake.
9. For creep operation, boom must be centered over front of machine, swing lock engaged, and load restrained from swinging. Travel slowly and keep the lifted load as close to the ground as possible, and especially avoid any abrupt steering, accelerating or braking.
10. Do not operate the crane while carrying the load.
11. Creep is motion for crane not to travel more than 200 ft. (60 m) in any 30 minute period and to travel at the speed of less than 1 mph (1.6km/h).
12. F

