



TEREX STINGER™ 4792/5092 Boom Truck Cranes

maximcrane.com

MAXIM
Crane Works, L.P.
1-877-MAX-LIFT



BT5092



BT4792

FEATURES

- 47,000 lbs. (21 319 kg) or 50,000 lbs. (22 680 kg) maximum lifting capacity
- 101 ft. (30.8 m) maximum sheave height
- 144 ft. (43.9 m) maximum sheave height with 44 ft. (13.4 m) jib
- 92 ft. (28.0 m) fully proportional four-section telescopic “keel” boom
- Exclusive color coded boom and load charts
- Easy-to-install optional 26-44 ft. (7.9-13.4 m) jib, man baskets or work platform increase job capabilities
- Choice of two 4792 configurations – behind cab (with either 180° or 360° work area) or rear mount. Choice of three 5092 configurations – behind cab (with either 180° or 360° work area), rear mount or riding seat
- Electronic Load Moment Indicator and anti-two-block device standard
- 2-speed planetary winch has 11,400 lb. (5171 kg) maximum line pull, 150/220 fpm (46/67 mpm) line speed
- Externally located planetary rotation drive for easy accessibility for maintenance
- Dual control stations with direct mechanically controlled hydraulic system (single station on RS 5092 model)
- Efficient load sensing, pressure-compensating hydraulic system has 90 gal. (340 l) capacity
- Terex Support Plus product service

simple, available and
cost effective™

Machines shown may have optional equipment.

STINGER 4792/5092 LOAD RATINGS

CAUTION: Do not use this specification sheet as a load rating chart. The format of data is not consistent with the machine chart and may be subject to change.

Load Ratings (Pounds) for 360° Full Capacity Work Area with Outriggers Extended and Optional Front Stabilizer

OPER. RADIUS (FT)	BOOM LENGTH											
	29 FT		44 FT		57 FT		71 FT		84 FT		92 FT	
	LOADED BOOM ANGLE (DEG)	LOAD RATING (LB)	LOADED BOOM ANGLE (DEG)	LOAD RATING (LB)	LOADED BOOM ANGLE (DEG)	LOAD RATING (LB)	LOADED BOOM ANGLE (DEG)	LOAD RATING (LB)	LOADED BOOM ANGLE (DEG)	LOAD RATING (LB)	LOADED BOOM ANGLE (DEG)	LOAD RATING (LB)
5	78	47,000*	*50,000 lbs for 5092 @ 29 ft boom length									
8	71	36,800	78	20,300								
10	67	30,900	75	20,300	79	18,400						
12	62	26,100	73	20,300	77	17,400						
14	58	21,900	70	19,400	75	16,800	78	14,600				
16	53	18,800	67	17,300	73	15,900	77	13,800	79	12,300		
20	41	14,200	61	13,900	68	13,400	73	12,300	76	10,900	78	9,825
25	21	10,400	53	10,900	63	10,600	69	10,400	73	9,800	75	9,025
30			45	8,625	57	8,625	65	8,425	69	8,225	71	7,425
35			34	6,925	51	6,925	60	6,925	66	6,725	68	6,325
40			19	5,225	44	5,625	56	5,625	62	5,625	65	5,425
45					36	4,625	50	4,625	58	4,625	61	4,625
50					26	3,725	45	3,725	53	3,725	57	3,725
55	BT & RM Models				1	1,225	38	3,025	49	3,025	53	3,025
60							31	2,425	44	2,425	49	2,425
65	NOTE: RATINGS ABOVE THE HEAVY LINE ARE BASED ON STRUCTURAL COMPETENCE AND NOT ON MACHINE STABILITY.						21	2,025	39	2,025	45	2,025
70									32	1,525	40	1,525
75									25	1,225	35	1,225
80									14	825	28	825

OPER. RADIUS (FT)	BOOM LENGTH											
	29 FT		44 FT		57 FT		71 FT		84 FT		92 FT	
	LOADED BOOM ANGLE (DEG)	LOAD RATING (LB)	LOADED BOOM ANGLE (DEG)	LOAD RATING (LB)	LOADED BOOM ANGLE (DEG)	LOAD RATING (LB)	LOADED BOOM ANGLE (DEG)	LOAD RATING (LB)	LOADED BOOM ANGLE (DEG)	LOAD RATING (LB)	LOADED BOOM ANGLE (DEG)	LOAD RATING (LB)
5	76	50,000										
8	70	34,525	77	20,300								
10	65	28,625	74	20,300	79	18,150						
12	60	23,575	72	20,000	76	17,225						
14	55	19,875	69	18,500	74	16,550	78	14,400				
16	49	17,175	66	16,500	72	15,500	76	13,600	79	12,125		
20	34	12,525	59	13,100	67	12,875	73	12,900	76	10,775	78	9,725
25			51	10,200	62	10,100	68	10,400	72	9,575	75	8,825
30			48	8,500	55	8,175	64	8,075	69	7,975	71	7,225
35			39	6,250	49	6,500	59	6,650	65	6,500	67	6,150
40					41	5,275	55	5,325	61	5,400	64	5,250
45					32	4,275	46	4,345	57	4,400	60	4,425
50					18	2,975	43	3,475	52	3,525	56	3,525
55	RS Model						36	2,800	47	2,825	52	2,825
60							28	2,250	42	2,275	48	2,275
65	NOTE: RATINGS ABOVE THE HEAVY LINE ARE BASED ON STRUCTURAL COMPETENCE AND NOT ON MACHINE STABILITY.								37	1,825	43	1,850
70									29	1,400	39	1,400
75									21	1,050	32	1,050
80											25	625

Stowed Jib Deductions (Pounds)

700	500	350	300	250	200
-----	-----	-----	-----	-----	-----

Range Diagram (29' - 92' boom) BT model shown. Range Diagrams for RM and RS models are similar.

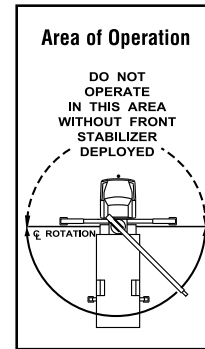
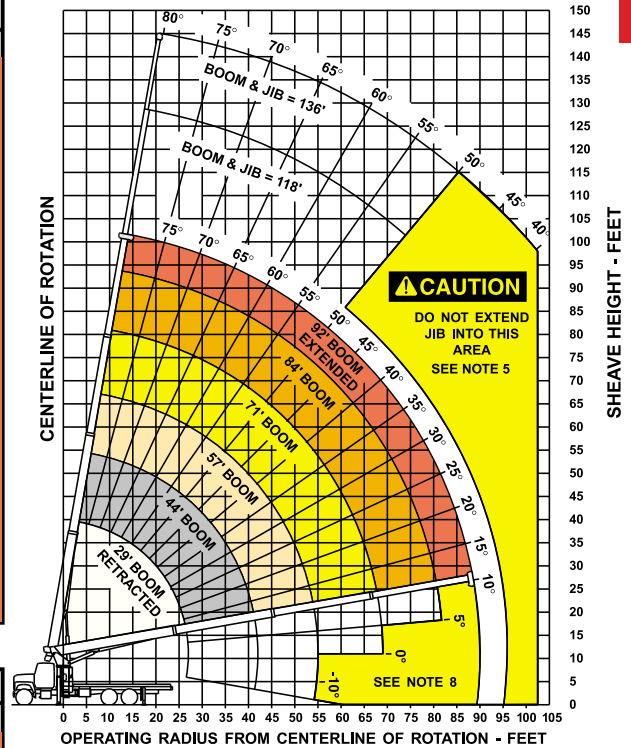

Deductions from Rated Loads for Handling Devices

OVERHAUL BALL:	175 lbs.
1 SHEAVE LOAD BLOCK:	200 lbs.
2 SHEAVE LOAD BLOCK:	250 lbs.
AUX. SHEAVE:	50 lbs.





JIB CAPACITIES FOR ALL BOOM LENGTHS
VERIFY OPERATIONAL MODE SETTING ON MG585 DISPLAY BEFORE LIFTING WITH JIB

Loaded Boom Angle	50°	55°	60°	65°	70°	75°	78°	80°
Retracted 26 ft. Jib	725	1025	1525	2325	3225	4325	4925	5325
Extended 44 ft. Jib	425	725	1125	1525	2025	2525	2825	3125

General Notes

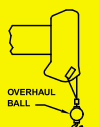
- The operator must read and understand the Owner's Manual before operating this crane.
 - Positioning or operation of crane beyond areas shown on this chart is not intended or approved except where specified in Owner's Manual.
 - Loaded boom angles at specified boom lengths give only an approximation of the operating radius. The boom angle before loading should be greater to account for deflections. Do not exceed the operating radius for rated loads.
 - Use rating of next longer boom for boom lengths not shown. Use rating of next greater radius for load radii not shown.
 - Boom must be fully retracted when jib is erected before lowering below minimum angle. Retracted jib has no lifting capacity below a 50° boom angle.
 - Use rating of next lower boom angle for boom angles not shown on jib load rating chart.
 - Lifting off the main boom point while the swing around jib is erected is not intended or approved.
 - Do not lower boom into this area, as hydraulic pressure will not allow raising the boom without retracting boom first.
 - Crane load ratings on outriggers are based on freely suspended loads with the machine leveled and standing on a firm uniform supporting surface. No attempt shall be made to move a load horizontally on the ground in any direction.
 - Practical working loads depend on supporting surface, wind and other factors affecting stability such as hazardous surroundings, experience of personnel, and proper handling, must all be taken into account by the operator.
 - The maximum load which may be telescoped is limited by hydraulic pressure, boom angle, and boom lubrication. It is safe to attempt to telescope any load within the limits of the load rating chart.
- INFORMATION**
- Deductions must be made from rated loads for stowed jib, optional attachments, hooks and loadblocks (see deduction chart). Weights of slings and other load handling devices shall be considered a part of the load.
 - Crane load ratings with outriggers are based on outriggers and stabilizers extended and set with all load removed from the carrier wheels.
 - Load ratings do not exceed 85% of tipping load.
- DEFINITIONS**
- Operating radius is the horizontal distance from the axis of rotation to the center of the vertical hoist line or load hook with load suspended.
 - Loaded boom angle as shown in the Load Ratings Chart is the included angle between the horizontal and longitudinal axes of the boom base after lifting rated load at rated radius.

WINCH DATA

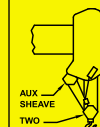
		1 Part Line	2 Part Line	3 Part Line	4 Part Line	5 Part Line
						
Winch	Cable Supplied	Lift and Speed	Lift and Speed	Lift and Speed	Lift and Speed	Lift and Speed
Standard Stationary Winch	9/16" Diam. IWRC XXIP	9,600 lb. 75.6 fpm*	19,200 lb. 37.8 fpm*	28,800 lb. 25.2 fpm*	47,000 lb. 18.9 fpm*	47,000 lb. 15.1 fpm*
	9/16" Diam. Rotation Resistant	6,720 lb. 75.6 fpm*	13,400 lb. 37.8 fpm*	20,160 lb. 25.2 fpm*	26,880 lb. 18.9 fpm*	33,600 lb. 15.1 fpm*

Block Type	Rating
Overhaul Ball	6.5 ton (5.9 mt)
1 Sheave Block	17 ton (15.4 mt)
2 Sheave Block	22.5 ton (20.4 mt)

CAUTION

Overload and anti-two-block systems must be in good operating condition before operating crane. Refer to Owners Manual. Keep at least 3 wraps of loadline on drum at all times. Use only 9/16" diameter cable with 33,600 lb. breaking strength on this machine.

*First layer speed. For fourth layer speed, multiply *value by 1.33, for burst speed, multiply by 1.7.

MOUNTING CONFIGURATIONS

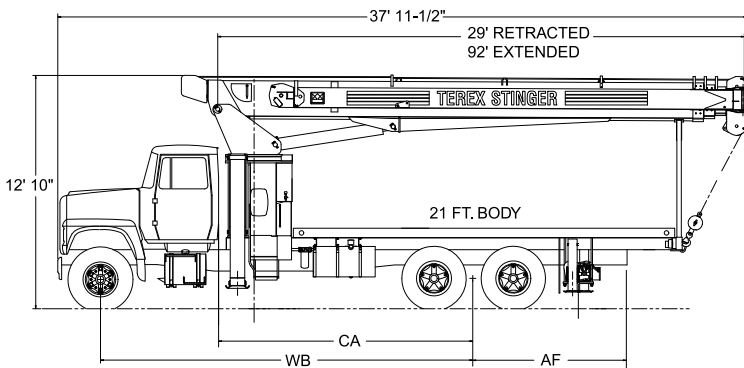

4792/5092 Behind Cab (BT) Mounting Configuration

	4792	5092
Gross Vehicle Weight Rating	52,000 lbs. (23 587 kg)	52,000 lbs. (23 587 kg)
Front Axle Weight Rating	18,000 lbs. (8165 kg)	18,000 lbs. (8165 kg)
Rear Axle Weight Rating	34,000 lbs. (15 422 kg)	34,000 lbs. (15 422 kg)
Wheelbase (WB)	246 in. (6248 mm)	261 in. (6629 mm)
Cab to Axle (CA)	168 in. (4267 mm)	180 in. (4572 mm)
Afterframe (AF)	100 in. (2540 mm)	100 in. (2540 mm)
Transmission (Neutral lock-up required for automatic transmission)		Heavy-Duty
Electrical System		Heavy-Duty
Cooling System		Heavy-Duty
Frame Section Modulus	26.0 in ³ (426 cm ³)	
RBM Per Frame Rail	2,860,000 in. lb. (32 950 m. kg)	

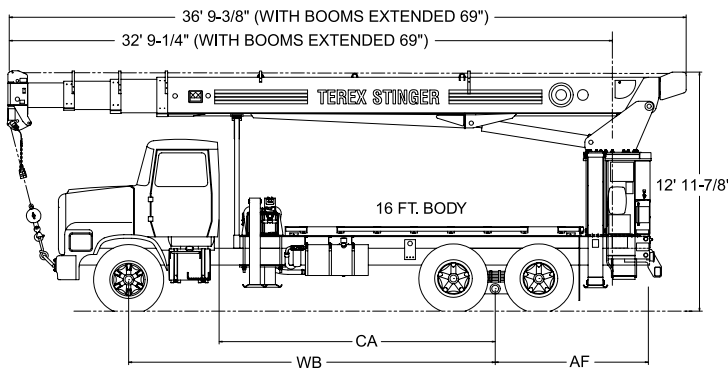

4792/5092 Rear Mount (RM) Mounting Configuration

	4792	5092
Gross Vehicle Weight Rating	52,000 lbs. (23 587 kg)	52,000 lbs. (23 587 kg)
Front Axle Weight Rating	18,000 lbs. (8165 kg)	18,000 lbs. (8165 kg)
Rear Axle Weight Rating	34,000 lbs. (15 422 kg)	34,000 lbs. (15 422 kg)
Wheelbase (WB)	246 in. (6248 mm)	261 in. (6629 mm)
Cab to Axle (CA)	180 in. (4572 mm)	192 in. (4877 mm)
Afterframe (AF)	100 in. (2540 mm)	114 in. (2896 mm)
Transmission (Neutral lock-up required for automatic transmission)		Heavy-Duty
Electrical System		Heavy-Duty
Cooling System		Heavy-Duty
Frame Section Modulus	26.0 in ³ (426 cm ³)	
RBM Per Frame Rail	2,860,000 in. lb. (32 950 m. kg)	

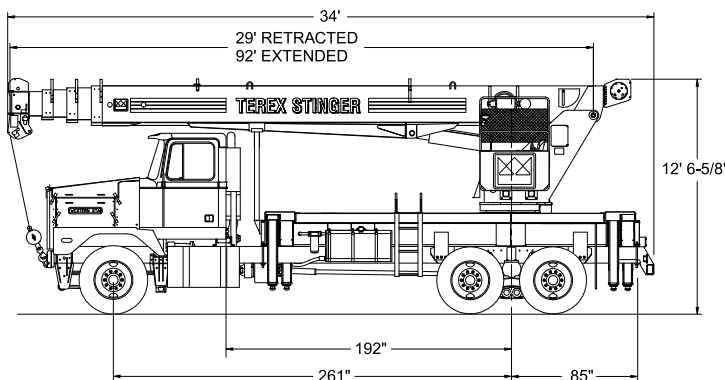

5092 Riding Seat (RS) Mounting Configuration

Gross Vehicle Weight Rating	58,000 lbs. (26 309 kg)
Front Axle Weight Rating	18,000 lbs. (8165 kg)
Rear Axle Weight Rating	40,000 lbs. (18 144 kg)
Wheelbase	261 in. (6629 mm)
Cab to Axle	192 in. (4877 mm)
Afterframe	85 in. (2159 mm)
Transmission (Neutral lock-up required for automatic transmission)	Heavy-Duty
Electrical System	Heavy-Duty
Cooling System	Heavy-Duty
Frame Section Modulus	30.0 in ³ (491 cm ³)
RBM Per Frame Rail	3,300,000 in. lb. (38 020 m. kg)

Notes: Some standard features for the optional mounting configurations will vary. Consult your Terex Cranes dealer or factory for chassis and mounting requirements.

TEREX STINGER 4792/5092

Boom Truck Cranes

SPECIFICATIONS

Boom

92 ft. (28.0 m) four section full power mechanically synchronized boom. Patented keel boom design utilizes a keel-shaped baseplate combined with a deep, four plate boom section to optimize strength / rigidity-to-weight ratio. Exclusive, patented color-coded boom and load charts allow the operator to easily and quickly determine boom extension, boom angle and load capacity. Maximum sheave height with four section 92 ft. (28.0 m) boom is 101 ft. (30.8 m). Maximum sheave height with optional two-stage 44 ft. (13.4 m) jib is 144 ft. (43.9 m).

Winch

Hydraulic winch with gear motor and planetary reduction gearing provides 2-speed "Burst-of Speed" operation. First layer rope pull is 11,400 lbs. (5171 kg). Wire rope size is 9/16" (14 mm) with 33,600 lbs. (15 241 kg) breaking strength.

Operating Speeds

Main frame / turret assembly planetary rotation provides 180° rotation (370° with optional front bumper outrigger). Swing rotation is 40 seconds. Boom up/down is 34/30 seconds and boom extend/retract is 80/36 seconds.

Hydraulics

Three section pump allows the operator to perform simultaneous crane operations (winch, boom and swing). Capacities are 36, 20 and 11 gpm (136.3, 75.7 and 41.6 lpm). Combined system capacity is 67 gpm (253.6 lpm).

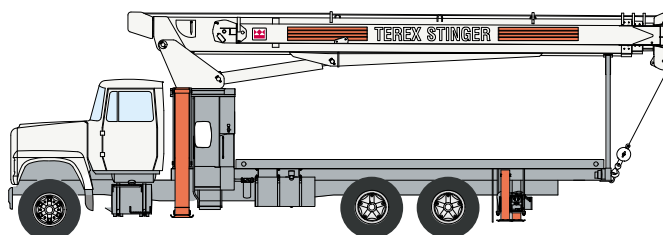

Controls

Fully proportional, excellent metering characteristics for precise boom movements. Independent outrigger controls allows the crane to be stable and level in rigorous working conditions. Load Moment Indicating System has audio alarm and functional shut down when operator encounters an overload situation.

Outriggers

Wide-stance link-type main outriggers on 4792 have a 20 ft. (6.1 m) pin-to-pin spread when fully extended. All 5092 configurations have 21 ft. (6.40 m) out-and-down main outriggers. Out-and-down rear outriggers have 17 ft. 6 in. (5.3 m) tip-to-tip span.

Subframe

Cross-braced, closed-box style subframe yields greater strength and rigidity. Wheel base for standard truck crane mounting configuration is 249 in. (6.27 m) for link-type main outriggers and 261 in. (6.63 m) for out-and down rear outriggers.

OPTIONS AND ACCESSORIES

Terex Stinger offers a wide range of options and accessories to customize your truck crane to your exact needs.

These include:

- Single and two-stage jibs
- Multi-part load blocks
- Auxiliary winch
- Spin-resistant load line
- Wood, steel or extra heavy duty steel flatbeds
- Radio remote controls
- One-man or two-man baskets
- Self-leveling work platform
- Winch drum tensioner
- Continuous rotation (standard on RS model)
- Oil cooler
- Rear bumper
- Single front bumper outrigger (required for 370° or continuous rotation on BT or RM models)
- Hydraulic hose reel
- Hydraulic auxiliary tool circuit
- Removeable cab (RS model only)

For more information, product demonstration, or details on purchase, lease and rental plans, please contact your local Terex Cranes dealer.

We reserve the right to amend these specifications at any time without notice. The only warranty applicable is our standard written warranty applicable to the particular product and sale. We make no other warranty, expressed or implied.

 **TEREX CRANES**

550 Old Highway 56
Olathe, KS 66061-4640 USA
(913) 782-1200 • FAX: (913) 782-1625
E-mail: olathe@terexlifting.com

www.terexlift.com