

Telescopic Truck Crane

LTM 1160/H

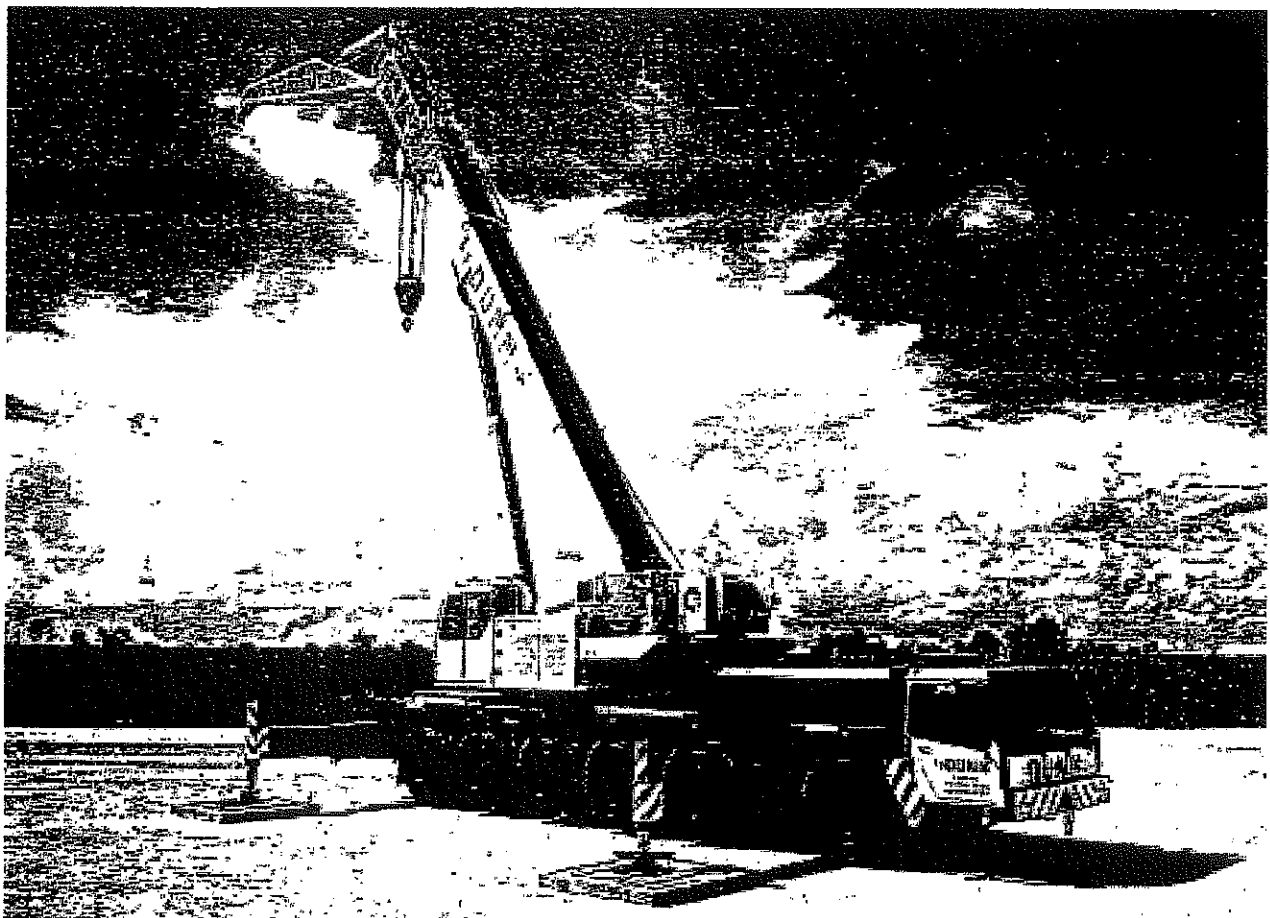

Dimensions.

LTM1160/1

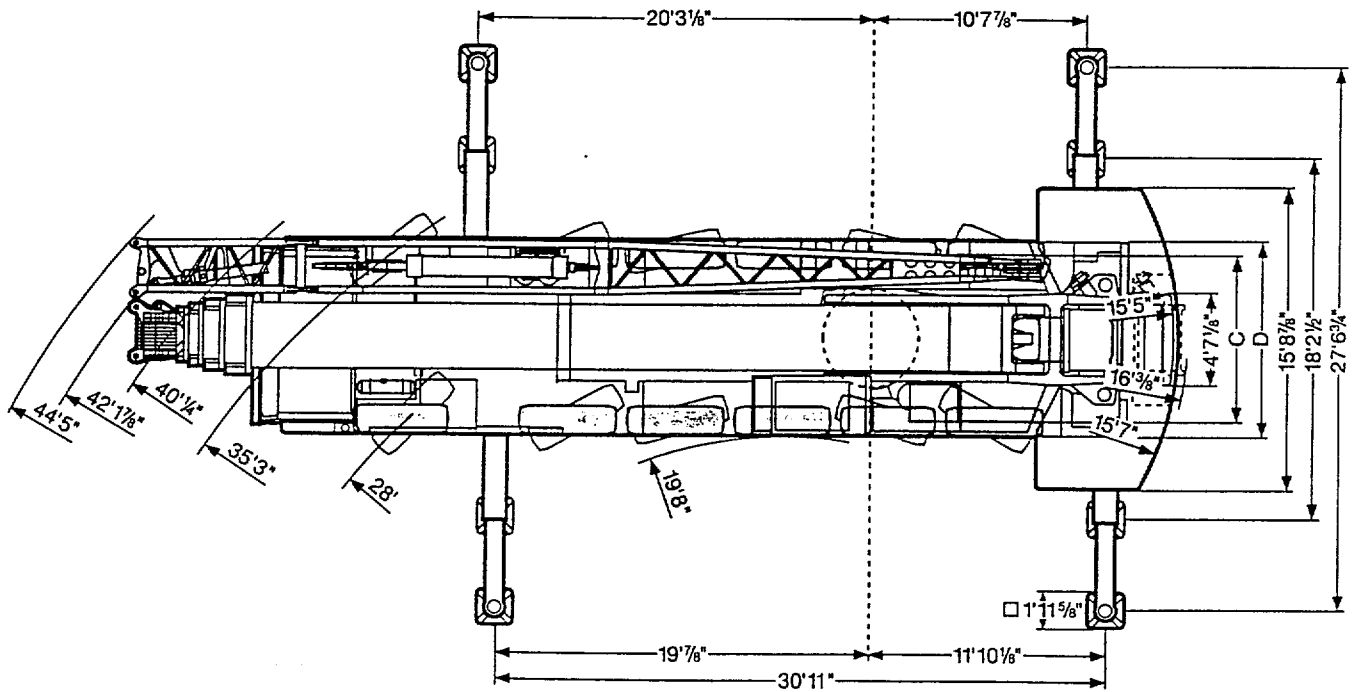
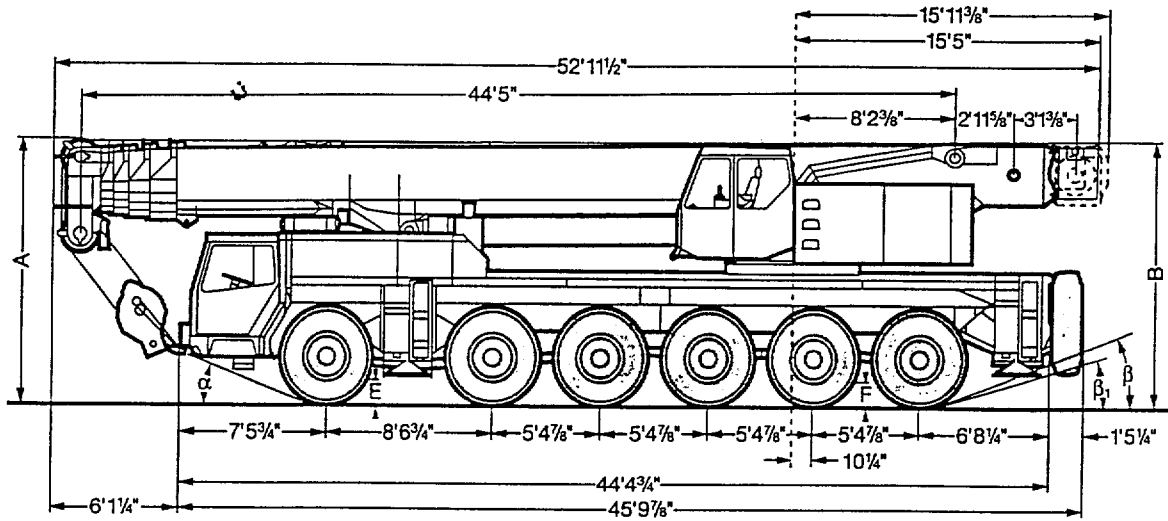

	Dimensions										
	A	A 5 7/8"	B	C	D	E	F	α	β	β ₁	
20.5 R 25	12'11 1/2"	12'5 3/8"	12'10 1/2"	8'7 3/4"	10'5"	14 1/4"	18 1/2"	21°	19.5°	15°	

* lowered

Weights.

LTM 1160/1



Axle	1	2	3	4	5	6	Total weight
lbs	26500	26500	26500	26500	26500	26500	159000*

* with 6600 lbs counterweight and folding jib



Load (kips)	No. of sheaves	No. of lines	Weight lbs
331	9	17	5291
302	7	15	3241
221	5	10	2756
150	3	7	1984
66	1	3	1676
22	-	1	860

Working speeds.



	1	2	3	4	5	R	
	9.6	15.4	23.7	35.2	48.7	9	-
	5.1	9	14	20.5	28.2	4.8	40%
	20.5 R 25						



Drive	infinitely variable	Rope diameter / Rope length	Max. single line pull
	0 - 427 ft/min single line	1/4" / 984'3"	22 295 lbs
	0 - 394 ft/min single line	1/4" / 656'2"	22 295 lbs
	0 - 1.6 rpm		
	approx. 70 seconds to reach 83° boom angle		
	approx. 120 seconds (300 seconds) for boom extension from 44 ft - 102 ft (44 ft - 171 ft)		

Lifting capacities of telescopic boom.

LTM 1160/1



44 ft - 171 ft



360°



101 500 lbs

85%

ft	44 ft		59 ft	73 ft	88 ft		102 ft	117 ft	132 ft		146 ft	160 ft	171 ft	ft
	"	"												
10	381	346												10
11	349	328												11
12	325	311	295											12
13	307	294	280											13
14	291	280	268	238	194	158								14
15	276	267	257	233	194	158	168							15
16	263	255	250	226	184	158	167							16
17	250	243	241	221	182	156	164	136						17
18	237	232	230	216	190	152	160	134						18
20		211	210	204	184	145	152	130	108	77.5				20
22		192	190	188	175	138	146	125	105	77.5				22
24		175	174	173	167	131	141	120	102	77.5	85			24
26		160	159	158	159	124	134	115	99	77.5	83.5			26
28		149	147	146	147	118	129	110	95.5	75	82	66		28
30		138	136	135	136	113	123	106	91.5	72.5	80	65.5	55.8	30
32		128	127	126	127	108	118	101	88	70	78.5	64.5	55.8	32
34			118	117	119	104	112	97.5	85	67.5	76.5	63.5	55.5	34
36			111	110	111	99.5	106	94	82	65	74	62	55	36
38			103	102	103	95.5	100	90	79	63	72	60.5	54.4	38
40			96	95	96.5	92	94.5	86.5	78	61	69.5	59.2	53.8	40
45			83	81.5	82.5	84	80.5	79	70	58	64	55.7	51.3	45
50				71	71.5	75.5	69.5	69.5	64.5	51.7	59.1	52.3	48.8	50
55				62	62	67	60.5	60.5	59.1	47.8	54.5	49	46.1	55
60					54.2	59.3	53.1	53.4	53.4	44.3	50.5	45.8	43.3	60
65					47.8	52.2	47	47.5	47.5	41.2	46.9	42.8	40.7	65
70					41.9	46.4	42	42.5	42.7	38.4	43.1	40.2	38.2	70
75					34	38.3	37.4	38.2	38.4	36	39.3	37.7	36	75
80							33.2	34.4	34.7	33.7	35.6	35.5	33.9	80
85							29.6	31	31.4	31.7	32.4	33.1	32	85
90							27.8	27.8	28.6	29.9	29.6	30.4	29.8	90
95								24.8	26	26.3	27.1	27.9	27.5	95
100								22.2	23.4	26.9	24.8	25.7	25.3	100
105									21.1	25.6	22.8	23.6	23.3	105
110									19	24	20.7	21.8	21.5	110
115									17.1	22.3	18.7	20	19.8	115
120											17	18.3	18.2	120
125											15.4	16.8	16.6	125
130											14	15.3	15.3	130
135												14	14	135
140												12.8	12.8	140
145													11.6	145
150													10.6	150
155													9.6	155
I	0		46	92	92	0	92/0	92	92	0	92	92	100	I
II	0		0	0	46	92	92/0	92	92	92	92	92	100	II
III	0		0	0	0	46	0/92	46	92	92	92	92	100	III
IV	0		0	0	0	0	0/92	0	0	92	46	92	100	IV

" over rear

TAB 89044 / 89045

Remarks referring to load charts.

1. The tabulated lifting capacities do not exceed 85 % of the tipping load.
2. The crane's structural steelwork is in accordance with DIN 15018, part 3. Design and construction of the crane comply with DIN 15018, part 2, and with F. E. M. regulations.
3. The 85 % overturning limit values take into account wind force 5 = wind speed 20 mph.
4. Lifting capacities are given in kips.
5. The weight of the hook blocks and hooks must be deducted from the lifting capacities.
6. Working radii are measured from the slewing centreline.
7. The lifting capacities given for the telescopic boom only apply if the folding jib is taken off.
8. Lifting capacities are subject to modifications.
9. Lifting capacities above 309 kips only with additional pulley block and special equipment.

Lifting capacities are given



44 ft - 171 ft



360°



78 300 lbs



ft	44 ft		59 ft	73 ft		88 ft		102 ft		117 ft	132 ft		146 ft	160 ft	171 ft	ft
	"	"	"	"	"	"	"	"	"	"	"	"	"	"	"	
10	312	282														10
11	295	282														11
12	279	276	268													12
13		264	254													13
14		251	243	216	89.5	176	143									14
15		239	233	211	86	176	143	153	88							15
16		228	225	206	82.5	176	143	152	88							16
17		217	215	200	79.5	175	141	149	88	124						17
18		206	204	194	76.5	172	138	145	87	122						18
20		184	182	181	71.5	167	132	138	85	119	98	70.5				20
22		167	165	165	67	159	125	133	81	114	95.5	70.5				22
24		152	151	150	62.5	149	119	128	77	109	92.5	70.5	77			24
26		139	138	137	59	138	113	122	73.5	105	90	70.5	76			26
28		128	127	126	55.8	127	108	117	70	100	86.5	68	74.5	59.9		28
30		118	117	116	52.8	117	103	111	67	96	83.5	65.5	73	59.6	50.7	30
32		110	108	107	50.2	108	98	104	64	92	80	63.5	71	58.6	50.7	32
34			100	99.5	47.8	101	94	96.5	61.5	88	77.5	61.5	69.5	57.5	50.4	34
36			94	93	45.7	93.5	90.5	90	59.3	84.5	74.5	59.2	67.5	56.3	50	36
38			87.5	86.5	43.6	86	87	83	56.9	80.5	72	57.2	65.5	55.1	49.5	38
40			81	80	41.6	80	83	77	54.7	76	69.5	55.3	63.5	53.8	48.9	40
45			67	66	37.6	67	71	65.5	49.9	65	63.5	50.9	58.2	50.6	46.6	45
50				54.8	34.2	56.4	60.5	56.4	45.7	56.3	55.8	47	53.7	47.5	44.3	50
55				46.1	31.3	47.6	51.7	48.4	42.1	49	48.8	43.4	48.8	44.5	41.9	55
60						40.5	44.5	41.3	38.9	42.8	42.9	40.3	43.5	41.7	39.4	60
65						35	38.8	35.7	35.9	37.3	38	37.4	38.7	38.9	37	65
70						30.4	34.2	31.2	33.2	32.8	33.8	35	34.7	35.3	34.3	70
75						26.4	30.4	27.2	30.9	28.8	29.9	32.7	31.2	31.9	31.3	75
80								23.6	28.7	25.3	26.5	30.4	28	28.8	28.3	80
85								20.6	26.9	22.2	23.4	27.8	25	26.1	25.7	85
90								18	25.3	19.6	20.8	25.3	22.4	23.6	23.3	90
95										17.2	18.4	23	20	21.3	21	95
100										15.2	16.3	21	17.9	19.1	18.9	100
105											14.4	19.1	15.9	17.2	17	105
110											12.7	17.5	14.3	15.5	15.3	110
115											11.2	15.9	12.7	14	13.8	115
120												11.3	12.6	12.3	120	
125												10	11.3	11.1	125	
130												8.9	10.1	9.9	130	
135													9	8.9	135	
140													8	7.9	140	
145														7.1	145	
150														6.3	150	
155														5.6	155	
ft	I	0	46	92	0	92	0	92	0	92	92	0	92	92	100	I
	II	0	0	0	0	46	92	92	0	92	92	92	92	92	100	II
	III	0	0	0	0	0	46	0	92	46	92	92	92	92	100	III
	IV	0	0	0	92	0	0	0	92	0	0	92	46	92	100	IV

" over rear

TAB 89026



44 ft - 171 ft



360°



6600 lbs

ft	44 ft	59 ft	73 ft	88 ft	102 ft	117 ft	132 ft	146 ft	160 ft	171 ft	ft		
10	299"	281									10		
11	282"	276									11		
12	263	262									12		
13	243	242									13		
14	227	225	204	173	143						14		
15	211	209	185	166	143	150					15		
16	198	191	167	151	143	137					16		
17	186	175	152	139	139	127	115				17		
18	175	160	140	128	131	118	109				18		
20	153	132	117	109	116	101	98	91	66		20		
22	131	113	101	95	102	88	84.5	80	66		22		
24	112	97.5	87	82.5	89.5	77	74	71	66	67.5	24		
26	98	84.5	75	71	78.5	73.5	65	62.5	66	61	26		
28	85	74	65.5	63	70	70	58.1	56.2	62.5	55.5	51.5	28	
30	73.5	64.5	57.3	55.2	62	66.5	51.8	50.4	58.1	50	49.3	30	
32	64	57.4	50.7	49.1	55.9	60.5	46.6	45.6	53.1	45.5	45.1	32	
34		51.4	47.8	44.1	50.7	55.3	42.2	41.5	48.9	41.7	41.5	34	
36		46.4	45.7	39.8	46.2	51	38.5	38	45.2	38.3	38.3	36	
38		41.4	43.6	35.6	41.8	46.7	34.7	34.4	41.5	35	35.1	38	
40		36.8	41.5	31.7	37.8	42.9	31.3	31.2	38.2	31.9	32.3	40	
45		27.7	36.1	24.6	30.4	35.6	24.8	25.1	31.7	26	26.6	45	
50			30	19.1	24.7	30	19.8	20.2	26.7	21.3	22.1	21.5	50
55			24.5	14.6	20.1	25.4	15.6	16.2	22.5	17.4	18.4	17.9	55
60				11	16.3	21.6	12.2	12.9	19	14.2	15.2	14.8	60
65				8	12.9	18.5	9.4	10.2	16.2	11.5	12.6	12.2	65
70					10.1	15.7	7	7.9	13.8	9.2	10.3	9.9	70
75					7.8	13.2			11.6	7.2	8.3	7.9	75
80						11.1			9.5		6.5	6.2	80
85						9.3			7.8		5	4.8	85
90						7.8			6.5				90
95									5.4				95
100									4.4				100
I	0	46	92/0	92	0	92/0	92	92	0	92	92	100	I
II	0	0	0/0	46	92	92/0	92	92	92	92	92	100	II
III	0	0	0/0	0	46	0/92	46	92	92	92	92	100	III
% IV	0	0	0/92	0	0	0/92	0	0	92	46	92	100	IV

" over rear

TAB 8902

Lifting heights.

LTM 1160/

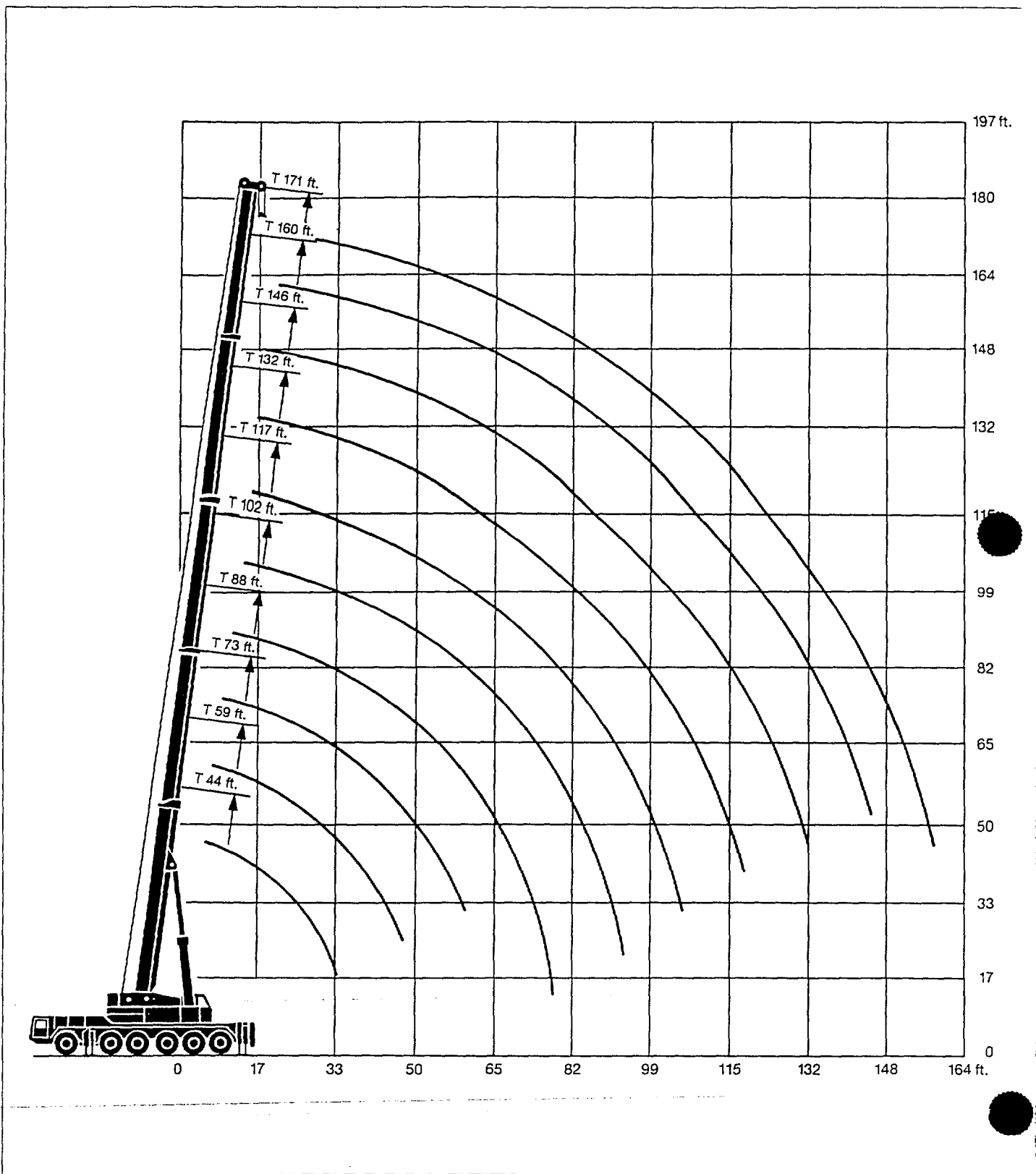

Lifting heights.

LTM 1160/1

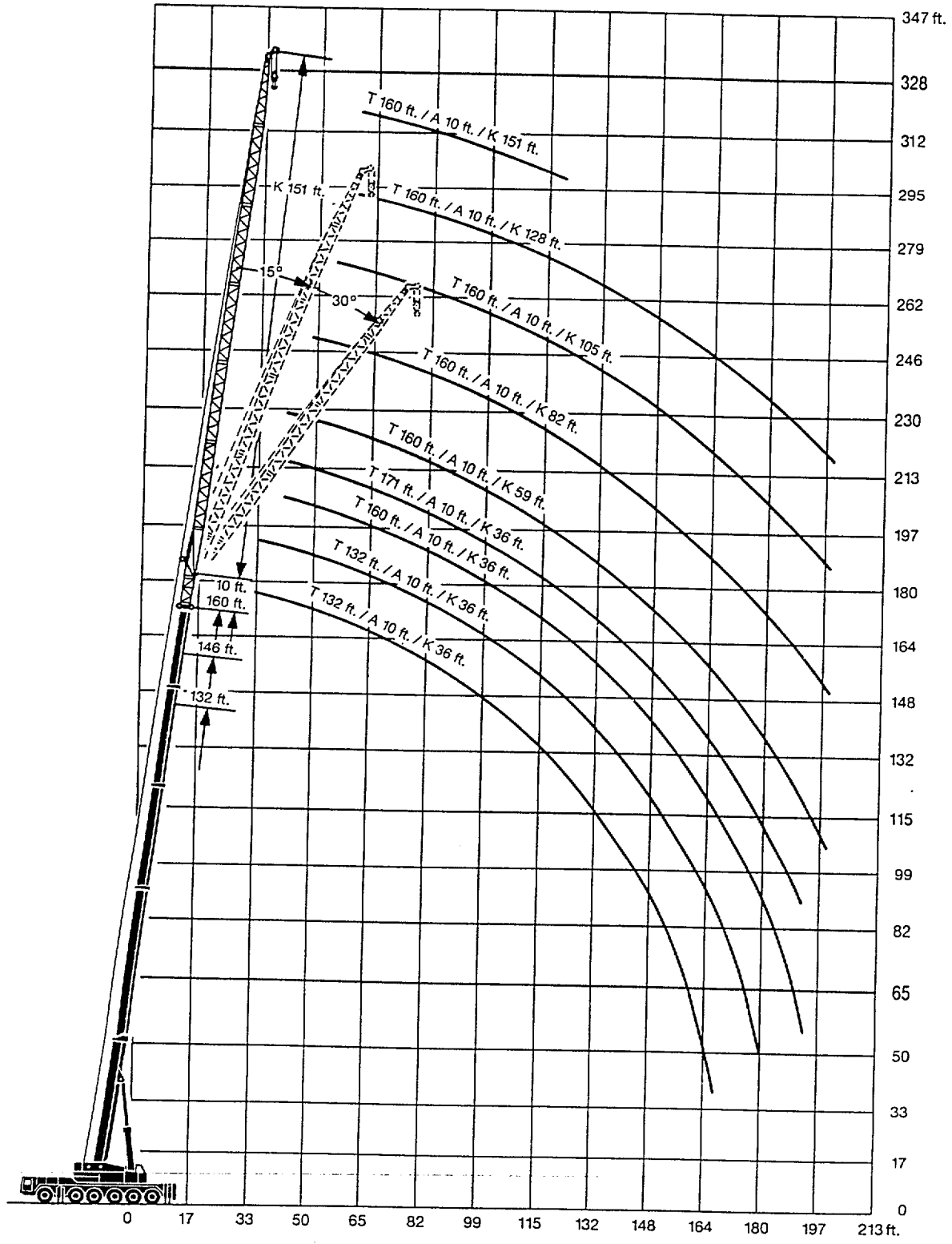

Lifting capacities at the luffing folding jib.

LTM 1160/1



44 ft* - 171 ft*



36 ft - 151 ft



360°



101 500 lbs

85%

ft	44 ft*						73 ft*						102 ft*						ft	
	36 ft	59 ft	82 ft	105 ft	128 ft	151 ft	36 ft	59 ft	82 ft	105 ft	128 ft	151 ft	36 ft	59 ft	82 ft	105 ft	128 ft	151 ft		
10	68.5																			10
11	64																			11
12	60																			12
13	56.7																			13
14	53	48.1					64													14
15	49.6	45					59.8													15
16	47.1	42.7					56.2													16
17	44.8	40.7	35.3				53.2													17
18	42.5	39	34.2				50.4													18
20	38.2	35.7	32.2				45.2	39.7					52.7							20
22	34.7	32.9	30.3				41.4	36.5					48.2							22
24	31.5	30.5	28.4	23.2			38.1	33.7	29.2				43.9	36.6						24
26	28.7	28.4	26.7	22			35.3	31.3	27.6				39.8	34.2						26
28	26.7	26.6	25	20.8	17.2		32.7	29.2	26.1	21.4			36.1	32.1						28
30	24.8	24.9	23.4	19.6	16.3		30.3	27.3	24.7	20.4			32.5	30.1	24.7					30
32	23	23.4	21.9	18.6	15.4		28.1	25.6	23.3	19.3			29.2	28.2	23.5					32
34		22	20.6	17.6	14.6	11.8		24.1	22.1	18.4	14.6		26.4	26.4	22.4	17.8				34
36		20.7	19.3	16.7	13.9	11.3		22.6	20.9	17.6	14		23.8	24.7	21.4	17				36
38		19.3	18.1	15.7	13.1	10.8		21.1	19.7	16.8	13.3		21.2	23	20.4	16.3				38
40		18.1	16.9	14.8	12.4	10.3		19.8	18.6	16	12.7	9.8		21.4	19.4	15.6	12.5			40
45		15.5	14.1	13	11	9.2		17	16.2	14.4	11.4	8.9		17.7	17.2	13.9	11.4			45
50		13.2	11.9	11.3	9.8	8.2		14.4	14.1	12.9	10.3	8.1		14.6	15.1	12.5	10.3	7.3		50
55			10.1	9.8	8.7	7.4		12	12.3	11.5	9.2	7.4		11.8	13.1	11.2	9.3	6.5		55
60			8.5	8.5	7.6	6.7			10.7	10.3	8.3	6.7			11.4	10	8.6	5.9		60
65			7.4	7.4	6.7	6.1			9.4	9.3	7.4	5.9			9.9	8.9	7.6	5.2		65
70			6.5	6.5	5.9	5.4			8.2	8.4	6.6	5.3			8.4	7.8	7	4.6		70
75			5.9	5.8	5.3	4.9			7.2	7.5	6	4.8			7	6.8	6.4	4.2		75
80				5.2	4.7	4.5				6.6	5.4	4.3			5.8	5.8	5.6	3.7		80
85				4.6	4.2	4.1				5.9	4.9	3.9			4.9	4.9	4.9	3.2		85
90				4.3	3.6	3.6				5.1	4.3	3.5			4.3	4.3	4.3	2.8		90
95				3.9	3.2	3.2				4.5	3.8	3.2				3.8	3.8			95
100					2.8	2.9				4	3.3	2.8				3.2	3.3			100
105												2.9					2.9			105
110												2.5					2.5			110
I			0						92						92					I
II			0						0						92					II
III			0						0						0					III
% IV			0						0						0					IV

ft	132 ft*						146 ft*						160 ft*						171 ft*	ft	
	36 ft	59 ft	82 ft	105 ft	128 ft	151 ft	36 ft	59 ft	82 ft	105 ft	128 ft	151 ft	36 ft	59 ft	82 ft	105 ft	128 ft	151 ft	36 ft		
30	38.3	28.8																			30
32	36.2	27.6																			32
34	34.2	26.5	19.7				30.7	22.4	16.3												34
36	32.1	25.3	19.1				29.6	21.9	16												36
38	30	24.1	18.4				28.6	21.3	15.6												38
40	28	22.9	17.7	14.4			27.5	20.7	15.3	11.7											40
45	22.8	20	16.1	13.3			24.6	19.2	14.5	11.2			27.1	18.4	12.9						45
50		17	14.6	12.3	9.3		20.4	17.3	13.6	10.7	7.4		23.5	17.5	12.7	9					50
55		14.6	13	11.4	8.7	6.4		15.6	12.8	10.2	7.1	4.9		16.5	12.5	8.9	5.6				55
60		12.8	11.4	10.5	8.1	6		14.1	11.8	9.6	6.9	4.7		15.4	12.2	8.7	5.6	3.4			60
65		10.9	9.9	9.4	7.6	5.6		12.1	10.6	8.9	6.6	4.5		13.4	11.3	8.5	5.6	3.4			65
70			8.7	8.4	7	5.3		10.4	9.5	8.3	6.3	4.3		11.5	10.2	8.2	5.6	3.4			70
75			7.5	7.5	6.5	5			8.4	7.6	6	4.2			9.2	7.7	5.6	3.4			75
80			6.4	6.7	5.9	4.8			7.3	6.9	5.7	4.1			8.3	7.1	5.5	3.4			80
85			5.9	6.1	5.4	4.4			6.6	6.3	5.3	3.8			7.3	6.6	5.1	3.2			85
90			5.1	5.4	5	4			5.8	5.8	4.9	3.4			6.4	6.2	4.8	2.8			90
95				4.7	4.5	3.7			4.9	5.2	4.4	4			5.5	5.7	4.4				95
100				4.3	4	3.3				4.7	4					5.2	4				100
105				3.9	3.6	2.9				4.2	3.6					4.6	3.6				105
110				3.5	3.3	2.7				3.8	3.4					4.1	3.5				110
115					2.9					3.3	3					3.5	3.1				115
120					2.6						2.7						2.8				120
I				92					92						92				100		I
II				92					92						92				100		II
III				92					92						92				100		III
% IV				0					46						92				100		IV

* with 10 ft adapter additional

Luffing folding jib.

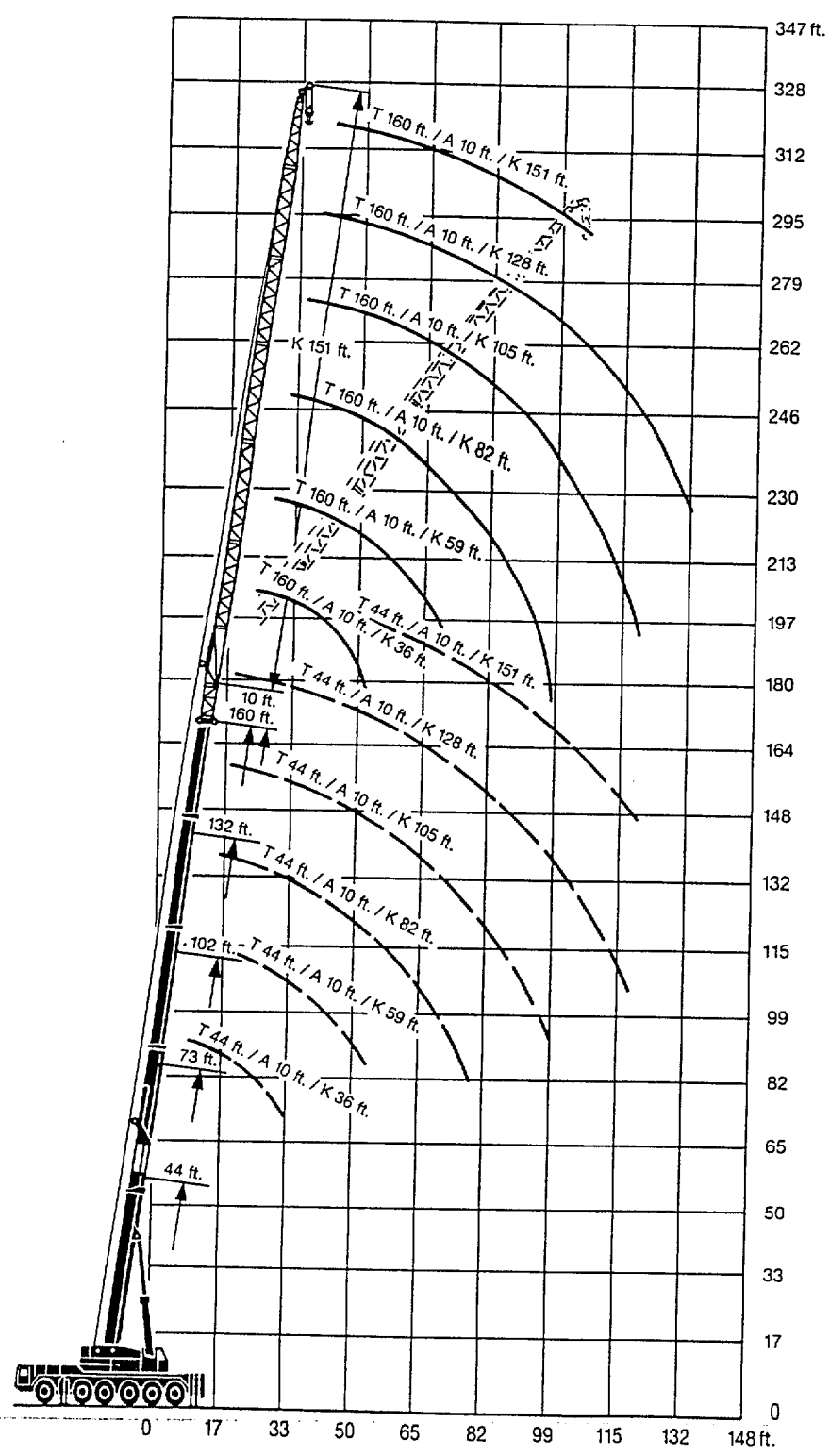

Telescopic boom: 83°

Lifting capacities at the lifting folding jib.

LTM 1160/1



44 ft* - 171 ft*

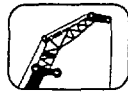

36 ft - 151 ft



360°

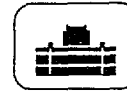

101 500 lbs

85%

ft	44 ft*						73 ft*						102 ft*						ft	
	36 ft	59 ft	82 ft	105 ft	128 ft	151 ft	36 ft	59 ft	82 ft	105 ft	128 ft	151 ft	36 ft	59 ft	82 ft	105 ft	128 ft	151 ft		
34	37																			34
36	34.1																			36
38	31.1																			38
40	28.5																			40
45	23.5																			45
50		19.8						28.5												50
55		16.6	16.7					23												55
60		13.9	14.4					21.2						31.7						60
65		11.5	12.6					17.7						24.9						65
70			10.9	10.3				15.1	14.5					19.3						70
75			9.4	9				12.8	12.8					17.8						75
80			8	7.8	7.1			11.3	9.9					15.2	14.6					80
85			6.9	6.9	6.4			9.8	8.6					13	12.7					85
90			5.6	6.1	5.6	4.6		8.8	7.6	7.1				11.1	11.4					90
95				5.5	5	4.1		7.9	6.8	6.3					10.1	9				95
100				4.9	4.4	3.7		7	6.1	5.7	4.7				8.9	8				100
105				4.4	3.9	3.2			5.3	5.1	4.4				7.8	7	6.1			105
110				3.8	3.5	2.8			4.8	4.7	3.8				7	6.3	5.5			110
115					3				4.2	4.4	3.4				6.3	5.6	5	4.1		115
120									3.7	4	3					4.8	4.4	3.7		120
125											3.6					4.1	3.9	3.4		125
130											3.2					3.5	3.5	3		130
135											3					3	3.1	2.6		135
140											2.8						2.8			140
I				0					92						92					I
II				0					0						92					II
III				0					0						0					III
% IV				0					0						0					IV %

ft	132 ft*						146 ft*						160 ft*						171 ft*	ft
	36 ft	59 ft	82 ft	105 ft	128 ft	151 ft	36 ft	59 ft	82 ft	105 ft	128 ft	36 ft	59 ft	82 ft	105 ft	128 ft	36 ft			
80	23.2																			80
85	19.6																			85
90		16.5						16.2												90
95		14						13					16.9							95
100		11.8	11.5					12.2										16		100
105			10.2					11.3	9					12.6						105
110			9.1					9.1	8.8					11.1						110
115			8	7.1				6.4	8.4					9.9						115
120			7	6.3				7.7	6.6					8.9	8.5					120
125			6.3	5.8	5.1			7	6.3					7.7	6.8					125
130			5.7	5	4.5			6.4	5.6					7.2	6.2					130
135				4.4	4.1	3		5.5	5.1	3.6				6.6	5.8					135
140				3.9	3.7	2.8			4.6	3.4				6.1	5.4					140
145				3.4	3.4				4.2	3.2					5.1	3.2				145
150				3	3				3.8	3.1					4.7	3.2				150
155					2.6				3.5	2.9					4.3	3.2				155
160															4	3.2				160
165															3.8	3.1				165
170															3.7	2.9				170
175																2.8				175
I				92					92						92			100		I
II				92					92						92			100		II
III				92					92						92			100		III
% IV				0					46						92			100		IV %

* with 10 ft adapter additional

Lifting heights.

LTM 1160/1

Luffing folding jib.

