

HTC-8640

40-ton (36.29 mt) Hydraulic Truck Crane

- 40-ton (36.29 mt) at a 9' (2.74 m) radius
- 105' (32.00 m) full-power, four-section boom with quick-reeve boom head
- 162' (49.38 m) maximum tip height
- Optional 51' (15.54 m) two-piece (bi-fold) lattice fly, stowable, offsettable to 2°, 20° and 40°
- No deducts for stowed attachment
- Full-deck aluminum fenders
- Pilot-operated hydraulic control
- On-highway 350 hp electronic Cummins engine
- 4,700 lb (2 132 kg) counterweight

HTC-8640

Heavy Lift

40-ton (36.29 mt) Hydraulic Truck Crane

The HTC-8640 Heavy Lift boasts all of the outstanding features of the HTC-8640, in addition to:

- An additional 5,000 lbs (2 268 kg) of counterweight for a total of 9,700 lbs (4 400 kg) significantly increases the lifting capacity and gives it the strongest chart in the three-axle, 40-ton (36.29 mt) capacity truck crane class
- On-highway 330 hp Cummins ISL engine with Jake Brake
- Heavy duty rear axles
- Larger rear tires 12R22.5

Link-Belt
CONSTRUCTION EQUIPMENT



HTC-8640

The HTC-8640 boasts the longest standard boom in the three-axle truck crane class in North America, and incorporates other proven Link-Belt features:

- A-max boom mode
- Confined Area Lifting Capacities (CALC)
- BOSS™ boom
- Ultra-Cab with CabWalk™

HTC-8640

Heavy Lift

All the great features of the HTC-8640 PLUS:

- Best 360° 40-ton lift capacities in the 3-axle class
- More counterweight
- Heavy duty rear axles



The Confined Area Lifting Capacities (CALC) system provides three outrigger positions:

- full retraction
- intermediate extension
- full extension

Outrigger pins eliminate guesswork by automatically positioning outriggers at midpoint position.

Link-Belt
CONSTRUCTION EQUIPMENT



Quick reeve head machinery for fast, easy line change. Hammerhead boom nose allows the operator to work at high boom angles without fouling wire rope. Deflector rollers prevent premature wire rope wear when working at low boom angles. Lightweight nylon head sheaves reduce overall machine weight and increase lift capacities. Available auxiliary lifting sheave is pinned on (not bolted) and requires only one man for installation. It can be used for quick lifts with one or two parts of line when the boom head has multiple reeving. And it remains on the boom through any fly combination, regardless of offset.

Longest standard boom in its class

- Full power, fully synchronized four-section, 33' to 105' (10.06 to 32.00 m) boom, with quick reeve boom head
- Maximum tip height is 162' (49.38 m) with the main boom and full attachment.
- The "Boss" is Link-Belt's patented boom design of high-strength angle cords and high formability sidewall embossments.



A-max



B mode

A-max mode

The basic boom extension (mode "B") self-proportions all four sections equally. The exclusive A-max mode (mode "A") extends only the inner mid-section to 57' (17.37 m), offering substantially increased capacities for in-close, maximum capacity picks and providing the operator the capability to match the crane's configuration to specific job site conditions.

Optional two-piece bi-fold lattice fly

- Erection of 28.5' - 51' (8.68 - 15.54 m) two-piece (bi-fold) lattice fly is a one-man operation
- Exclusive design reduces side deflection when lifting loads
- Easy to erect and stow
- Also available: 28.5' (8.68 m) one-stage, swing-away lattice attachment
- Attachments offset to 2°, 20° and 40°

Sheppard rack & pinion steering system provides 40° wheel cuts and a 40' turning radius

Non-slip surface strips on carrier deck

Link-Belt's innovative two-part paint coating technology, coupled with a pre-assembly paint process, provides the finest quality coating system available today. This enhances the overall aesthetic appeal of the final machine, as nuts, bolts, hoses and various parts are no longer painted. As a result, paint chipping, cracking and deterioration is significantly reduced when service work and disassembly are required. The paint is baked on to totally cure the paint before assembly.

Aluminum wheels and front/rear radial tires are rated for use on 70-ton cranes, and are interchangeable with all other cranes in the HTC series.

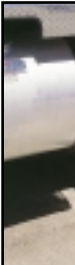

Piston motor hydraulic hoist system

Standard **load hoist system** consists of a main winch with two-speed piston motor and automatic brake for power up/down mode of operation. A bi-directional hydraulic motor, driving a planetary reduction unit provides precise load control with minimal rpm's.

Asynchronous, parallel double cross-over grooved drums minimize rope harmonic motion, improving spooling and increasing rope service life. A two-speed auxiliary winch is an available option.

For greater productivity and control, the five pump-section hydraulic circuit provides smooth, simultaneous function of winches, boom hoist, swing and boom telescope.



The Ultra-Cab is roomier and quieter than traditional cabs

- Six-way adjustable fabric seat with lift-up armrest (which deactivates control functions when raised)
- Armrest mounted, responsive **dual axis hydraulic controllers**
- Bubble level **sight level** mounted on side console
- **Ducted air** through automotive-style directional vents
- **Sliding right side**, rear windows and swing-up roof window
- **Single foot pedal** control of boom telescope
- **Automotive-style windshield**
- Corner-post-mounted **backlit gauges**
- **Dashless design**
- Large, sweeping **electric wipers**
- **Interchangeable with entire HTC and RTC lines**, with exception of the RTC-8030 Series II and RTC-8060



Mechanical boom angle indicator - standard



4,700 lb (2 132 kg) base counterweight integral with upper structure (standard). Optional two 1,000 lb (454 kg) counterweight inserts bring counterweights up to 6,700 lb (3 046 kg).

"Heavy Lift" counterweight configuration - 9,700 lb (4 400 kg): All of the above, in addition to a 3,000 lb (1 361 kg) removable counterweight



Access to the operator's cab is convenient with the pull-out CabWalk™ slide out cat walk. The CabWalk™ easily slides out from its secure travel position underneath the operator's cab.

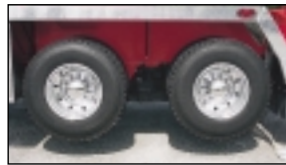

Another first from Link-Belt, the **axle lift system** holds the rear axles level while the crane is on outriggers.



Two standard **carrier-mounted outrigger controls**, located on each side of the carrier, include a throttle-up switch that brings engine up to 1,200 rpm's for fast outrigger deployment. For fine level adjusting of the carrier, throttle can be taken down to idle.

Smooth ride with air-ride suspension

Standard on all HTC-8640's, the air-ride suspension provides a smooth ride and precise handling. For pick-and-carry operations, the four air bags are deflated allowing the suspension to rest solid on the carrier frame. Before lifting the load, simply flip one switch in the carrier's cab and the bags automatically deflate. When the pick-and-carry operation is completed, flip the same switch and the air bags automatically re-inflate.

In addition to Link-Belt's smooth travelling and precise handling air-ride suspension, heavy duty rear axles and 12R22.5 tires have been added on the HTC-8640HL.

Integral rated capacity limiter

The Microguard 434 aids the operator in safe and efficient operation by continuously monitoring boom length, boom angle, head height, radius of load, machine configuration, allowed load, actual load and percent of allowed load.

An exclusive feature on the HTC-8640 is the Operator Defined Area Alarm. By setting two points, the operator creates an imaginary vertical plane to maintain a safe working distance from nearby obstacles. Should the operator attempt to operate the crane beyond the plane, the RCL will sound an alarm.

The Microguard 434 also features:

- Improved access time
- Radio frequency shielding
- Large liquid crystal alpha-numeric display
- Total system override capabilities to provide for rigging requirements
- Optional graphic display bar, positioned near the top of the windshield for optimum viewing during crane operation alerts the operator of the current lift capacity through a series of green, yellow and red lights.

Stow 'n Go outrigger pontoons are quickly and easily stored and secured for travel, eliminating the need to remove the outrigger's pontoon each time the crane moves. Outrigger pontoon storage space is also available on the rear fenders and side carrier access ladders.





Carrier cab

The carrier cab and engine cowling are manufactured of the same LFC 2000 construction process as the upper operator's cab. This rust-free, laminated fibrous composite material combined with additional acoustical treatments assure the operator of maximum highway comfort. And the rack and pinion steering puts the operator in complete control. Interchangeable with entire HTC line.

Additional comfort and safety features include:

- Dash mounted comprehensive instrumentation with back-lighted gauges
- Sliding side and rear windows and roll up/down door window provides excellent ventilation
- Ducted air through automotive-style directional vents
- Fully adjustable air ride fabric seat
- Suspended pedals
- Rear view mirrors
- Tilt steering column

Cruise to the next job site at 59 mph

The HTC-8640 is outfitted with a Cummins ISC-350 engine and a 9-speed manual transmission. The Cummins ISL-330 engine with engine compression brake, or "Jake Brake," is an available option and is standard on the "Heavy Lift."

Transmission

- 9-speed forward & 2-speed reverse manual transmission (standard)
- Automatic 6-speed forward & 1-speed reverse transmission with 2-speed auxiliary transmission is available on the HTC-8640 and the "Heavy Lift."
- 59 mph maximum highway travel speed
- 6 x 4 drive (standard)

Serviceability

Wide opening engine doors provide excellent accessibility, all fittings are staggered for easy servicing, and standard quick disconnects installed at various locations in the hydraulic system allow the hydraulic pressure to be quickly and easily checked with Link-Belt's exclusive diagnostic kit (optional). The driver can use the stop engine and check engine indicator lights to troubleshoot the engine. An engine diagnostic connector, located under the carrier cab dash, allows an engine service technician to further analyze engine problems with an engine diagnostic data reader.



FOR MORE INFORMATION, CONTACT YOUR AUTHORIZED LINK-BELT DISTRIBUTOR:

Link-Belt
CONSTRUCTION EQUIPMENT

Lexington, Kentucky
www.linkbelt.com

© Link-Belt is a registered trademark. Copyright 2001. All rights reserved. We are constantly improving our products and therefore reserve the right to change designs and specifications.

Litho in U.S.A. 8/01 #4263

Specifications

Telescopic Boom Truck Crane

HTC-8640

40-ton (36.29 metric tons)

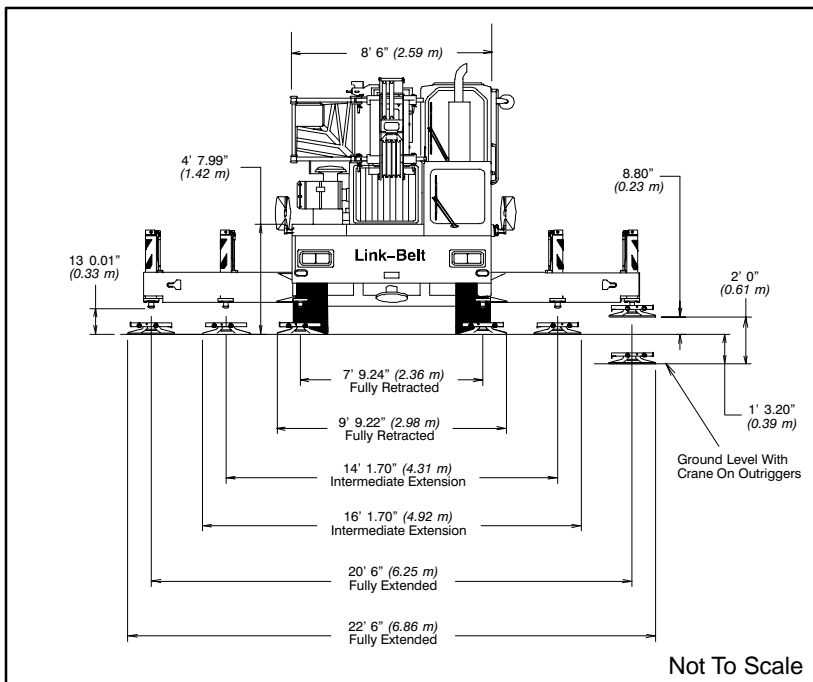
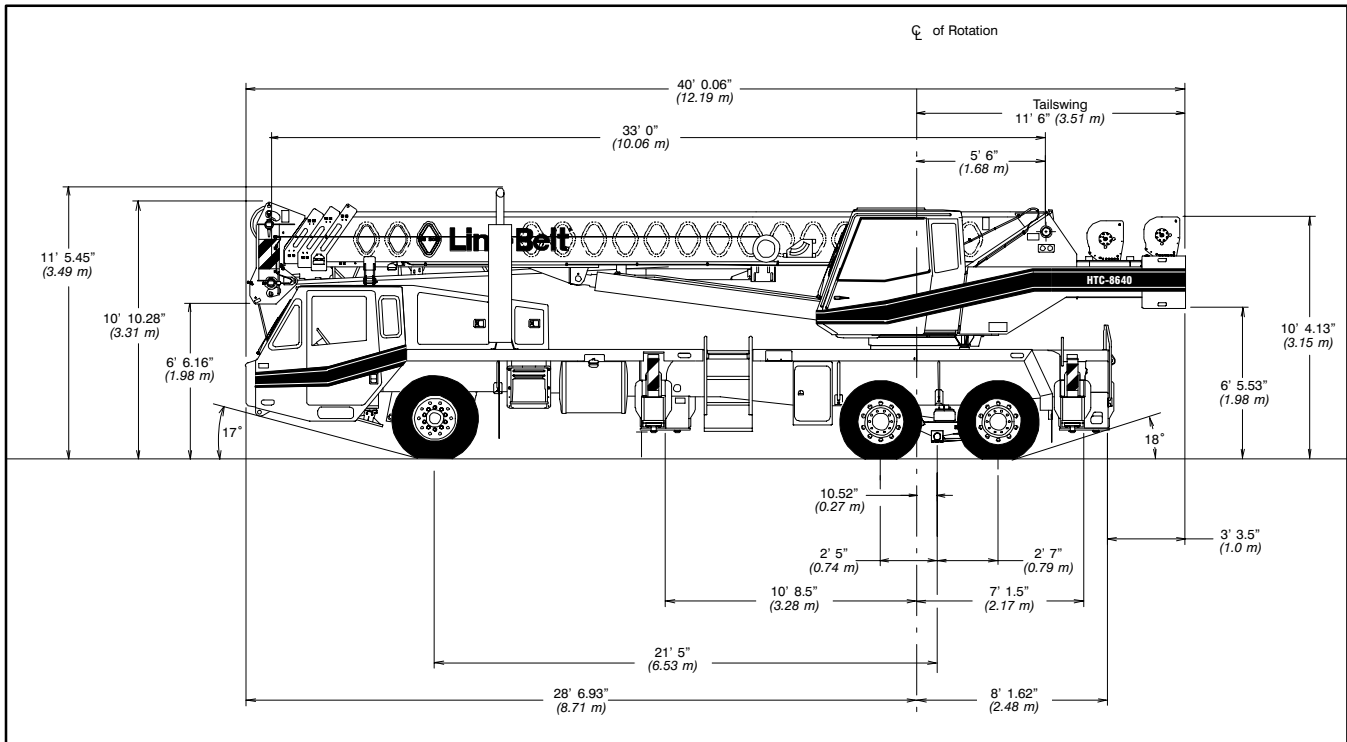

General Dimensions	feet	meters
Turning radius – wall to wall	44' 2"	13.46
Turning radius – curb to curb	39' 6"	14.44
Ground clearance	13"	.33
Tailswing	11' 6"	3.51

Upper Structure

■ Boom

Patented Design

- Boom side plates have diamond shaped impressions for superior strength to weight ratio and 100,000 p.s.i. (689.5 MPa) steel angle chords for lateral stiffness.
- Boom telescope sections are supported by top, bottom and adjustable side wear shoes to prevent metal to metal contact.

Boom

- 33' – 105' (10.06 – 32.00 m) four-section full power boom.
- Two mode boom extension
- The basic mode is the full power, synchronized mode of telescoping all sections proportionally to 105' (32.00 m).
- The exclusive "A-max" mode (or mode 'A') extends only the inner mid section to 57' (17.37 m) offering increased capacities for in-close, maximum capacity picks.
- Mechanical Boom Angle Indicator

Boom Head

- Four 16.5" (0.42 m) root diameter nylon sheaves to handle up to eight parts of wire rope.
- Easily removable wire rope guards
- Rope dead end lugs provided on each side of boom head.
- Boom head designed for quick reeve of hook block.

Boom Elevation

- One Link-Belt designed hydraulic cylinder with holding valve and bushing in each end.
- Hand control for controlling boom elevation from -3° to +78°.

Optional Auxiliary Lifting Sheave

- Single 16.5" (0.42 m) root diameter nylon sheave with removable wire rope guard, mounted to boom.
- Use with one or two parts of line off the optional front winch.
- Does not affect erection of fly or use of main head sheaves for multiple reeving.

Optional

- 25-ton (22.7 mt) quick reeve hook block.
- 40-ton (36.3 mt) quick reeve hook block.
- 8.5-ton (7.7 mt) hook ball.
- Boom floodlight.

■ Fly

Optional

- 28.5' (8.69 m) offsettable stowable one-piece lattice type with lugs to allow for addition of second section. Can be offset 2°, 20° or 40°.
- 28.5' – 51' (8.69 – 15.54 m) offsettable stowable 2-piece lattice type. Can be offset 2°, 20° or 40°.

■ Cab and Controls

Environmental Ultra-Cab™

- Laminated fibrous composite material; isolated from sound with acoustical fabric insulation.

- Windows are tinted and tempered safety glass.
- Sliding rear and right side windows and swing-up roof window for maximum visibility and ventilation.
- Slide-by-door opens to 3' (0.91 m) width.
- Six-way adjustable seat for maximum operator comfort.
- Hand-held outrigger controls and sight level bubble located in cab.
- Diesel cab heater
- Pull-out Cabwalk™
- Audible swing alarm
- Fire extinguisher
- 12-volt accessory outlet
- Electric windshield wiper
- Windshield washer
- Top hatch window wiper
- Circulating fan
- Warning horn
- Cup holder
- Sun screen
- Hand throttle
- Mirrors
- Dome light

Optional

- Amber strobe light
- Amber rotating beacon
- Hydraulic heater
- Air conditioning

Controls

Hydraulic controls (joy-stick type) for:

- Swing
- Main winch
- Optional auxiliary winch
- Boom hoist

Foot controls for:

- Boom telescope
- Swing brake
- Engine throttle

Optional

- Auxiliary winch
- Single axis controls

Cab Instrumentation

Cornerpost-mounted gauges for:

- Hydraulic oil temperature
- Audio/Visual warning system
- Tachometer
- Oil pressure
- Voltmeter
- Fuel
- Water temperature

■ Rated Capacity Limiter

- **Microguard 434** Graphic audio-visual warning system built into dash with anti-two block and function limiters.

Operating data available includes:

- Machine configuration.
- Boom length
- Boom angle
- Head height
- Radius of load
- Allowed load
- Actual load
- % of allowed load

Presetable alarms include:

- Maximum and minimum boom angles.
- Maximum tip height.
- Maximum boom length.
- Swing left/right positions.
- Operator defined area alarm is standard.
- Anti-two block weight designed for quick reeve of hook block.

Optional

- **Internal RCL light bar:** Visually informs operator when crane is approaching maximum load capacity with a series of three lights; green, yellow and red.
- **External RCL light bar:** Visually informs ground crew when crane is approaching maximum load capacity kickouts and pre-settable alarms with a series of three lights; green, yellow and red.

■ Swing

- Bi-directional hydraulic swing motor mounted to a planetary reducer for 360° continuous smooth swing at 2.8 r.p.m.
- **Swing park brake** – 360°, electric over hydraulic (spring applied, hydraulic released) multi-disc brake mounted on the speed reducer. Operated by toggle switch in overhead control console.
- **Swing brake** – 360°, foot operated, hydraulic applied disc brake mounted on the speed reducer.
- **Swing lock** – Standard; two position travel lock operated from the operator's cab.
- **Counterweight**
 - Standard – Bolted to upper structure frame. 4,700 lbs. (2 132 kg) one piece design.
 - Optional – 2,000 lbs. (907 kg) additional counterweight can be inserted into pockets in main counterweight.

Optional

- 360° swing lock. Meets New York City requirements.

■ Hydraulic System

Main Pump

- One gear pump with a total of four sections.
- Combined pump capacity of 131 gpm (488 lpm).
- Powered by carrier engine through power take-off (PTO).
- Spline type pump disconnect, mechanically activated pump disconnect engaged / disengaged from carrier cab.
- Maximum system operating pressure is 3,350 psi (23 098 kPa).
- O-ring face seals technology used throughout with hydraulic oil cooler standard.

Steering / Fifth Outrigger Pump

- Single gear type pump, 6 gpm (23 lpm). Powered by carrier engine through front gear housing.
- Max. pump operating pressure is 2,000 psi (13 790 kPa). Reservoir – 131 gallon (507.2 L) capacity. One diffuser for deaeration.

Filtration

- One 10-micron filter located inside hydraulic reservoir.
- Accessible for easy replacement.

Control valves

- Five separate pilot operated control valves allow simultaneous operation of all crane functions.

Load Hoist System

Standard

- 2M main winch with grooved lagging.
- Two-speed motor and automatic brake.
- Power up/down mode of operation.

- Bi-directional piston-type hydraulic motor driven through planetary reduction unit for positive control under all load conditions.
- Asynchronous parallel double crossover grooved drums minimize rope harmonic motion.
- Pressure compensated winch circuit provides balanced oil flow to both winches for smooth, simultaneous operation.
- Rotation resistant wire rope.
- Drum rotation indicators.

Line Pulls and Speeds

- Maximum available line pull 13,010 lbs. (5 901 kg) and maximum line speed of 480 f.p.m. (146 m/min) on 10.63" (0.27 m) root diameter grooved drum.

Optional

- 2M auxiliary winch with two-speed motor, automatic brake, and winch function lock-out. Power up/down modes.
- Hoist drum cable followers.
- Third wrap indicators.

Carrier

Type

- 8' 6" (2.59 m) wide, 257" (6.53 m) wheel-base. 6 x 4 drive – standard.

Frame

- 100,000 p.s.i. (689.5 MPa) steel, double walled construction with integral 100,000 p.s.i. steel outrigger boxes.

Optional

- Carrier mounted storage boxes.
- Pintle hook.
- Electric and air connections for trailers.

Axles

Front

- Single, 83.22" (2.11 m) track.

Rear

- Tandem, 76.17" (1.93 m) track. 5.57 to 1.0 ratio with interaxle differential with lockout (6.17:1 ratio with automatic transmission).

Suspension

Front axle

- Leaf spring suspension.

Rear axle

- Air-ride, bogie beam type, suspension.

Wheels

Standard

- Hub piloted steel disc.

Optional

- Hub piloted aluminum disc.
- Spare tire and wheel assemblies.

Tires

Standard Front

- 425/65R22.5 (Load range "L") single tubeless radials.

Standard Rear

- 275/80R22.5 (Load range "H") dual tubeless radials.

Optional Rear

- 11R22.5 (Load range "H") dual tubeless radials.

Brakes

Service

- Full air brakes on all wheel ends with automatic slack adjusters. Dual circuit with modulated emergency brakes.
 - Front – 16.5 x 6 S-Cam brakes.
 - Rear – 16.5 x 7 S-Cam brakes.

Parking/Emergency

- One spring set, air released chamber per rear axle end.
- Parking brake applied with valve mounted on carrier dash.
- Emergency brakes apply automatically when air drops below 40 psi (275.8 kPa) in both systems.

Steering

- Sheppard rack and pinion design.

Optional

- Remote drive and steer.

Transmission

Standard

- Eaton RTX-11609B; 9 speeds forward, 2 reverse.

Optional

- Automatic Allison MD 3066, 65:1 high, 3.49:1 low.

Auxiliary

- Eaton 2A-92, two speed– High: 1.0:1 Low: 2.3:1 (with automatic transmission only).

Electrical

- Two 12-volt batteries provide 12-volt starting. 160-amp alternator.
- 1,400 cold cranking amps available.
- 12-volt operating system,

Lights

- Four dual beam sealed headlights.
- Front, side, and rear directional signals.
- Stop, tail and license plate lights.
- Rear and side clearance lights.
- Hazard warning lights.

Outriggers

- Three position operation capability.
- Four hydraulic, telescoping beam and jack outriggers.
- Vertical jack cylinders equipped with integral holding valve.
- Beams extend to 20' 6" (6.25 m) centerline-to-centerline and retract to within 8' 6" (2.59 m) overall width.
- Equipped with stowable, lightweight 24" (0.61 m) diameter aluminum floats.
- Standard fifth outrigger, 16" (0.41 m) self storing steel pad is operable from ground or operator's cab.
- Hand-held controls and sight level bubble located on carrier deck.

Confined Area Lifting Capacities (CALC™) System

- The crane is operational in one of the three outriggers positions and operational in confined areas in two positions (intermediate and full retraction). The three outrigger positions are:
 - Full extension – 20' 6" (6.25 m).
 - Intermediate position – 14' 1.70" (4.31 m).
 - Full retraction – 7' 9.24" (2.36 m).
- Capacities are available with the outrigger beams in the intermediate and full retraction positions.
- When the outrigger position levers (located on the outrigger beams) are engaged, the operator can set the crane in the intermediate or full retraction outrigger position without having to leave the cab.

Carrier Cab

- One-man cab of laminated fibrous composite material acoustical insulation with cloth covering.

Equipped with:

- Air-ride, six-way adjustable operator's seat.
- Four-way adjustable tilting and lockable steering wheel.
- Door and windows locks.
- Left-hand and right-hand rear view mirrors.
- Sliding right-hand and rear tinted windows.
- Roll up/down left-hand tinted window.
- Desiccant-type air dryer.
- Steps to upper, lower cab and rear carrier.
- 120-volt electric engine block heater.
- Back-up warning alarm.
- Tow hooks and shackles.
- Aluminum fenders with ground control outriggers.
- Electric windshield wiper and washer.
- Travel lights
- Fire extinguisher
- 36,000 BTU heater
- Dome light
- Mud flaps
- Horn
- Ashtray
- Defroster
- Cruise control

Optional

- Rotating Beacon
- Amber Strobe Light
- Air conditioning

Cab instrumentation

- Illuminated instrument panel speedometer.
- Tachometer
- Fuel gauge
- Oil pressure gauge
- Turn signal indicator
- Water temperature gauge.
- Front and rear air pressure gauges.
- Audio/visual warning system.
- Automotive type ignition.
- Hourmeter
- Fuses
- Odometer
- Voltmeter

Carrier Speeds *(Manual Transmission – Standard tires)*

Gear	High				Low					Hi Rev.	Lo Rev.	Low Rev. @700 rpm	Low @700 rpm
	8	7	6	5	4	3	2	1	Low	Rev.	Rev.	Low Rev.	Low
Ratio	0.73	1.00	1.38	1.95	2.79	3.83	5.28	7.47	12.57	3.43	13.14	13.14	12.57
Speed	mph	58.92	43.01	31.17	22.06	15.42	11.23	8.15	5.76	3.42	12.54	3.12	1.04
	km/hr.	94.80	69.20	50.15	35.49	24.08	18.07	13.11	9.26	5.51	20.18	5.03	1.68

Engine

Engine – standard	Cummins ISC 350	Engine – optional	Cummins ISL 330 with Jake Brake
Cylinders – cycle	6 / 4	Cylinders – cycle	6 / 4
Bore	4.49" (114 mm)	Bore	4.49" (114 mm)
Stroke	5.32" (135 mm)	Stroke	5.69" (145 mm)
Displacement	504.5 cu. in. (8 268 cm ³)	Displacement	540 cu. in. (8 849 cm ³)
Maximum brake hp.	350 @ 2,000 rpm; 335 @ 2,200 rpm	Maximum brake hp.	345 @ 1,900 rpm; 330 @ 2,100 rpm
Peak torque	1,050 ft. lbs. (1 560 J) @ 1,300 rpm	Peak torque	1,150 ft. lbs. (1 559.2 J) @ 1,300 – 1,400 rpm
Electric system	12–volt neg. ground/12 volt starting	Electric system	12–volt neg. ground / 12 volt starting
Fuel capacity	75 gallons (284 L)	Fuel capacity	75 gallons (284 L)
Alternator	12 volt, 160 amps	Alternator	12 volt, 160 amps
Crankcase capacity	20 qts. (19 L)	Crankcase capacity	29 qts. (28 L)

Axle Loads

Base machine with standard 33' – 105' (10.06 – 32.00 m) four–section boom, 2M main winch with 2–speed hoisting and power up/down, 450' (137 m), 5/8" (19 mm) wire rope, 8 x 4, 8.5' (2.59 m) carrier with Cummins ISC 350 Engine, 75 gal. (284 L) fuel, aluminum fenders and 4,700 lb. (2 132 kg.) counterweight.	G.V.W. ¹		Upper Facing Front			
	lbs.	kg.	Front Axle		Rear Axle	
			lbs.	kg.	lbs.	kg.
	56,828	25 777	17,607	7 986	39,221	17 790
One–quarter tank of diesel fuel	–394	–179	–269	–122	–125	–57
Left side carrier aluminum storage box	57	26	14	6	43	20
Right side carrier aluminum storage box	57	26	14	6	43	20
Cummins ISL–330 engine with engine brake	25	11	23	10	2	1
Six–speed automatic transmission and two–speed auxiliary transmission with engine brake	601	273	266	121	335	152
Tire and aluminum disc 425/65R22.5 fronts – 11R22.5 rears	–520	–236	–110	–50	–410	–186
Air conditioning – Carrier cab	124	56	135	61	–11	–5
Pintle hook w/air and electrical hook–ups	32	15	–9	–4	41	19
Driver in carrier cab	200	91	236	107	–36	–16
Cab heater assembly (hydraulic)	110	50	–8	–4	118	5
Air conditioning – Operator cab	315	143	–35	–16	350	159
Rear winch roller	77	35	–31	–14	108	49
Front winches with two speeds and 450' (137.2 m) of wire rope	312	141	–93	–43	405	184
Front winch roller	77	35	–22	–10	99	45
Remove rear winch rope (450')	–365	–166	161	73	–526	–239
Remove front winch rope (450')	–365	–166	120	54	–485	–220
360 degree Mechanical House Lock	60	27	–2	–1	62	28
Add 2,000 lbs of counterweight (6,700 lbs. total)	2,000	907	–868	–394	2,868	1 801
Fly brackets to boom base section for fly options	116	53	62	28	54	24
28.5' (8.69 m) offsettable fly w/ATB weight (stowed)	1,184	537	839	381	345	156
28.5' – 51' (8.69 – 15.54 m) offsettable fly w/ATB weight (stowed)	1,757	797	1,141	518	616	279
Floodlight to front of boom base section	10	5	13	6	–3	–1
25–ton (22.7 mt) hook block stowed behind bumper (3–sheaves)	670	304	784	356	–114	–52
40–ton (36.3 mt) hook block stowed behind bumper (4–sheaves)	780	354	913	414	–133	–60
Hookball to front bumper	360	163	421	191	–61	–28
Auxiliary arm w/ATB switch to boomhead	110	50	153	69	–43	–20

¹ Adjust gross vehicle weight & axle loading according to component weight. Note: All weights are ± 3%

Axle	Max. Load @ 65 mph. (105 km/h)
Front	22,700 lbs. (10 297 kg) – steel or aluminum disc wheels
Rear	44,000 lbs. (19 958 kg) – steel or aluminum disc wheels

Lifting Capacities

Telescopic Hydraulic Truck Crane

HTC-8640 40-ton (36.3 metric ton)

Boom and fly capacities for this machine are listed by the following sections:

Fully Extended Outriggers

- Working Range Diagrams (4,700 lbs. and 6,700 lbs. Counterweight)
- 33 to 57 ft. main boom capacities, A-max mode
- 33 to 105 ft. main boom capacities, Basic Mode "B"
- 28.5 ft. offset fly capacities, Basic Mode "B"
- 28.5 to 51 ft. two-piece offset fly capacities, Basic mode "B"

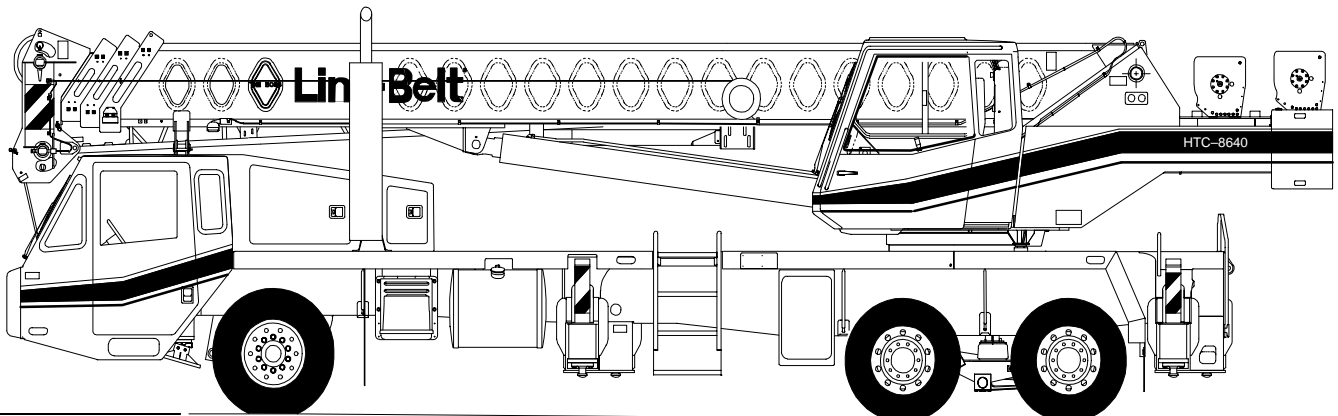

CAUTION: This material is supplied for reference use only. Operator must refer to in-cab Crane Rating Manual to determine allowable machine lifting capacities and operating procedures.

Table Of Contents

Page	Contents
3–4	Operating Instructions
5	Tire Inflation
5	Pontoon Loadings
5	Boom Mode “A” and “B”
5	Winch Performance
5	Wire Rope Capacity
5	Hydraulic Circuit Pressure Settings
5	Working Areas
5	Capacity Deductions for Auxiliary Load Handling Equipment

Fully Extended Outriggers

6	Working Range Diagram, 4,700 lbs. Counterweight
7–8	Lifting Capacities, 4,700 lbs. Counterweight
9	Working Range Diagram, 6,700 lbs. Counterweight
10–11	Lifting Capacities, 6,700 lbs. Counterweight



WARNING

READ AND UNDERSTAND THE OPERATOR'S AND SAFETY MANUALS AND THE FOLLOWING INSTRUCTIONS AND RATED LIFTING CAPACITIES BEFORE OPERATING THE CRANE. OPERATION WHICH DOES NOT FOLLOW THESE INSTRUCTIONS MAY RESULT IN AN ACCIDENT.

OPERATING INSTRUCTIONS

GENERAL:

- 1 . Rated lifting capacities in pounds as shown on lift charts pertain to this crane as originally manufactured and normally equipped. Modifications to the crane or use of optional equipment other than that specified can result in a reduction of capacity.
- 2 . Construction equipment can be dangerous if improperly operated or maintained. Operation and maintenance of this crane must be in compliance with the information in the Operator's, Parts, and Safety Manuals supplied with this crane. If these manuals are missing, order replacements through the distributor.
- 3 . The operator and other personnel associated with this crane shall read and fully understand the latest applicable American National Standards ASME B30.5 safety standards for cranes.
- 4 . The rated lifting capacities are based on crane standing level on firm supporting surface.

SET UP:

- 1 . The crane shall be leveled on a firm supporting surface. Depending on the nature of the supporting surface, it may be necessary to have structural supports under the outrigger pontoons or tires to spread the load to a larger bearing surface.
- 2 . When making lifts on outriggers, all tires must be free of supporting surface. All outrigger beams must be extended to the same length; fully retracted, intermediate extended, or fully extended. The front bumper outrigger must be properly extended.
- 3 . When making lifts on tires, they must be inflated to the recommended pressure. (See Operation note 20 and Tire Inflation.)
- 4 . Before swinging boom to over side position on tires, boom sections must be fully retracted.
- 5 . For required parts of line, see Wire Rope Capacity and Winch Performance.
- 6 . Before setting up on intermediate outriggers, retracted outriggers, or tires, refer to Working Range Diagrams and rated lifting capacities to determine allowable crane configurations.

OPERATION:

- 1 . Rated lifting capacities at rated radius shall not be exceeded. Do not tip the crane to determine allowable loads. For concrete bucket operation, weight of bucket and load shall not exceed 80% of rated lifting capacities. For clamshell bucket operation, weight of bucket and bucket contents is restricted to a maximum weight of 6,000 pounds or 80% of rated lifting capacity, whichever is less. For magnet operation, weight of magnet and load is restricted to a maximum weight of 6,000 pounds or 80% of rated lifting capacity, whichever is less. For clamshell and magnet operation, maximum boom length is restricted to 50 ft. and the boom angle is restricted to a minimum of 35 degrees. Lifts with either fly erected is prohibited for both clam and magnet operation.
- 2 . Rated lifting capacities shown on fully extended outriggers do not exceed 85% of the tipping loads. Rated lifting capacities shown on intermediate extended or fully retracted outriggers are determined by the formula, rated load = (tipping load – 0.1 X load factor)/1.25. Rated lifting capacities shown on tires do not exceed 75% of the tipping loads. Tipping loads are determined by SAE crane stability test code J–765.
- 3 . Rated lifting capacities in the shaded areas are based on structural strength or hydraulic limitations and have been tested to meet minimum requirements of SAE J–1063 cantilevered boom crane structures—method of test. The rated lifting capacities in non–shaded areas are based on stability ratings. Some capacities are limited by a maximum obtainable 78° boom angle.
- 4 . Rated lifting capacities include the weight of the hook ball/block, slings, bucket, magnet and auxiliary lifting devices. Their weights must be subtracted from the listed rated capacity to obtain the net load which can be lifted. Rated lifting capacities include the deduct for either fly stowed on the base of the boom. For deducts of either fly erected, but not used, see Capacity Deductions For Auxiliary Load Handling Equipment.

- 5 . Rated lifting capacities are based on freely suspended loads. No attempt shall be made to move a load horizontally on the ground in any direction.
- 6 . Rated lifting capacities are for lift crane service only.
- 7 . Do not operate at radii or boom lengths (minimum or maximum) where capacities are not listed. At these positions, the crane can tip or cause boom failure.
- 8 . The maximum loads which can be telescoped are not definable because of variation in loadings and crane maintenance, but it is permissible to attempt retraction and extension within the limits of the applicable load rating chart.
- 9 . For main boom capacities when either boom length or radius or both are between values listed, proceed as follows:
 - a . For boom lengths not listed, use rating for next longer boom length or next shorter boom length, whichever is smaller.
 - b . For load radii not listed, use rating for next larger radius.
- 10 . The user shall operate at reduced ratings to allow for adverse job conditions, such as: soft or uneven ground, out of level conditions, wind, side loads, pendulum action, jerking or sudden stopping of loads, hazardous conditions, experience of personnel, traveling with loads, electrical wires, etc. Side load on boom or fly is dangerous and shall be avoided.
- 11 . Rated lifting capacities do not account for wind on suspended load or boom. Rated capacities and boom length shall be appropriately reduced as wind velocity approaches or exceeds 20 mph.
- 12 . When making lifts with auxiliary head machinery, the effective length of the boom increases by 2 ft.
- 13 . Power sections of boom must be extended in accordance with boom mode "A" or "B". In boom mode "B" all power sections must be extended or retracted equally.
- 14 . The least stable rated working area depends on the configuration of the crane set up.
- 15 . Rated lifting capacities are based on correct reeving. Deduction must be made for excessive reeving. Any reeving over minimum required (see Wire Rope Capacity) is considered excessive and must be accounted for when making lifts. Use Working Range Diagram to estimate the extra feet of rope then deduct 1 lb. for each extra foot of wire rope before attempting to lift a load.
- 16 . The loaded boom angle combined with the boom length give only an approximation of the operating radius. The boom angle, before loading, should be greater to account for deflection. For main boom capacities, the loaded boom angle is for reference only. For fly capacities, the load radius is for reference only.
- 17 . For fly capacities with main boom length less than 105 ft. and greater than 80 ft., the rated capacities are determined by the boom angle using the 105 ft. boom and fly chart. For angles not shown use the next lower boom angle to determine the rated capacity.
- 18 . For fly capacities with main boom length less than 105 ft. and greater than 80 ft., the rated capacities are determined by the boom angle using the 105 ft. boom and fly chart. For angles not shown use the next lower boom angle to determine the rated capacity.
- 19 . For fly capacities with main boom length less than 80 ft., the rated capacities are determined by the boom angle only using the 80 ft. boom and fly chart. For angles not shown, use the next lower boom angle to determine the rated capacity.
- 20 . The 33 ft. boom length structural lifting capacities are based on boom fully retracted. If the boom is not fully retracted, do not exceed capacities shown for the 40 ft. boom length.
- 21 . Rated lifting capacities on tires depend on tire capacity, condition of tires, and tire air pressure. On tire capacities require lifting from main boom head only on a smooth and level surface. The boom must be centered over the rear of the crane with two position travel swing lock engaged and the load must be restrained from swinging. Rated lifting capacities on tires are limited to creep speed. For correct tire pressure, see Tire Inflation.

DEFINITIONS:

- 1 . Load Radius: Horizontal distance from a projection of the axis of rotation to the supporting surface, before loading, to the center of the vertical hoist line or tackle with load applied.
- 2 . Loaded Boom Angle: \angle° The angle between the boom base section and horizontal with freely suspended load at the rated radius.
- 3 . Working Area: Area measured in a circular arc about the center line of rotation as shown on the Working Area Diagram.
- 4 . Freely Suspended Load: Load hanging free with no direct external force applied except by the hoist line.
- 5 . Side Load: Horizontal side force applied to the lifted load either on the ground or in the air.
- 6 . No Load Stability Limit: The radius or boom angle beyond which it is not permitted to position the boom because the crane can overturn without any load on the hook.
- 7 . Load Factor: Load applied at the boom tip which gives the same moment effect as the boom mass.
- 8 . Creep: Crane movement not exceeding 200 ft. in a 30 minute period and 1 mph maximum speed.

BOOM EXTENSION

Boom Mode "A"	Boom Length (ft.)
Only inner mid section telescopes	33
	40
	50
	57
Inner Mid Section 288" Stroke	Base Section

Boom Mode "B"	Boom Length (ft.)		
Inner mid, outer mid and tip sections telescope simultaneously.	33		
	40		
	50		
	60		
	70		
	80		
	90		
	100		
	105		
Tip Section 288" Stroke	Outer Mid Section 288" Stroke	Inner Mid Section 288" Stroke	Base Section

TIRE INFLATION

Tire Size	Operation	Tire Pressure (psi)
11 R 22.5	Creep	120
275/80 R 22.5	Creep	120

PONTOON LOADINGS

Maximum Pontoon Load:	Maximum Pontoon Ground Bearing Pressure:
61,750 lbs.	137 psi

CAPACITY DEDUCTIONS FOR AUXILIARY LOAD HANDLING EQUIPMENT

Load Handling Equipment:	(lbs.)
Auxiliary Head Attached	100
25-ton quick reeve 3 sheave hook block (see hook block for actual weight)	670
40-ton quick reeve 4 sheave hook block (see hook block for actual weight)	780
8.5-ton hook ball (see hook ball for actual weight)	360
Lifting From Main Boom With:	(lbs.)
28.5 ft. or 51 ft. fly stowed on base (see operation note 4)	0
28.5 ft. offset fly erected but not used	2600
51 ft. offset fly erected but not used	4800
Lifting From 28.5 ft. Offset Fly With:	
22.5 ft. fly tip erected but not used	PROHIBITED
22.5 ft. fly tip stowed on 28.5 ft. offset fly	PROHIBITED
Note: Capacity deductions are for Link-Belt supplied equipment only.	

WINCH PERFORMANCE

Wire Rope Layer	Winch Line Pulls		Drum Rope Capacity (ft.)	
	Two Speed Winch		Layer	Total
	Low Speed Available Lbs.*	High Speed Available Lbs.		
1	13,010	6,418	77	77
2	11,768	5,805	85	162
3	10,742	5,299	93	255
4	9,881	4,874	101	356
5	9,148	4,513	109	465

*Maximum lifting capacity: Type RB Rope=9,080, Type ZB Rope=11,080

WIRE ROPE CAPACITY

Maximum Lifting Capacities Based On Wire Rope Strength			
Parts of Line	5/8"	5/8"	Notes
	Type RB	Type ZB	
1	9,080	11,080	Capacities shown are in pounds and working loads must not exceed the ratings on the capacity charts in the Crane Rating Manual. Study Operator's Manual for wire rope inspection procedures and single part of line applications.
2	18,160	22,160	
3	27,240	33,240	
4	36,320	44,320	
5	45,400	55,400	
6	54,480	66,480	
7	63,560	77,560	
8	72,640	88,640	
9	81,720	—	
LBCE	DESCRIPTION		
TYPE RB	18 X 19 Rotation Resistant – Compact Strand, High Strength Preformed, Right Regular Lay		
TYPE ZB	36 X 7 Rotation Resistant – Extra Improved Plow Steel – Right Regular Lay		

HYDRAULIC CIRCUIT PRESSURE SETTINGS

Function	Pressure (PSI)
Front And Rear Winch	3100
Outriggers	3000
Boom Hoist	3350
Telescope	3000
Swing	1500
Steering	2000
Bumper Outrigger	650
Pilot Control	500

WORKING AREAS

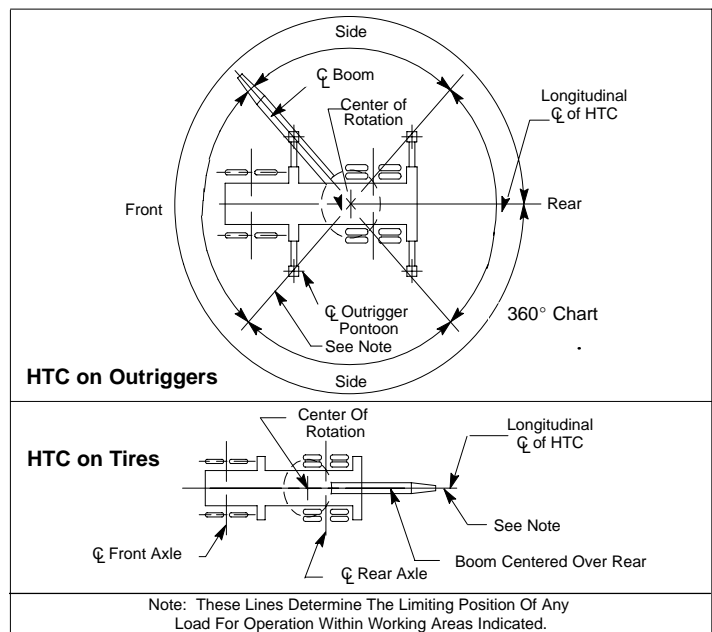

WORKING RANGE DIAGRAM

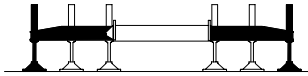

Fully Extended Outriggers

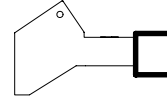

4700 # Counterweight

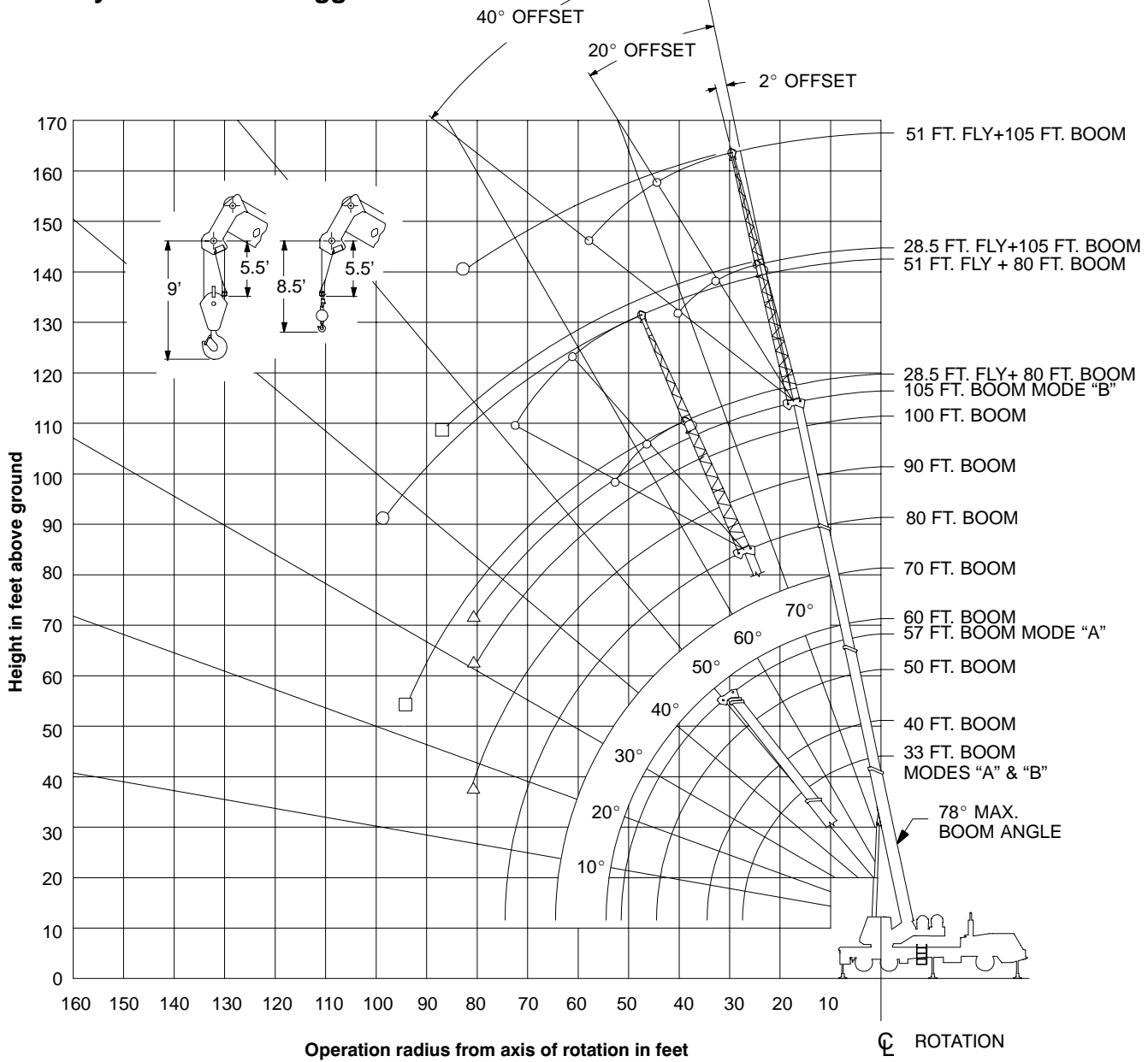

- Denotes Main Boom + 51' Offset Fly-Boom Mode "B"
- Denotes Main Boom + 28.5' Offset Fly-Boom Mode "B"
- △ Denotes Main Boom - Boom Mode "B"

Note: Boom and fly geometry shown are for unloaded condition and crane standing level on firm supporting surface. Boom deflection, subsequent radius and boom angle change must be accounted for when applying load to hook.



WARNING

Do Not Lower The Boom Below The Minimum Boom Angle For No Load Stability As Shown In The Lift Charts For The Boom Lengths Given. Loss Of Stability Will Occur Causing A Tipping Condition.

Rated Lifting Capacities In Pounds Fully Extended Outriggers See Set Up Note 2

4,700 lbs.

FULL EXTENSION

MAIN BOOM "A"

Load Radius (Ft.)	33 Ft.			40 Ft.			Load Radius (Ft.)
	∠°	360°	Over Rear	∠°	360°	Over Rear	
9	68.0	80,000	80,000				9
10	66.0	72,300	72,300	70.5	72,300	72,300	10
12	62.0	65,500	65,500	67.5	65,200	65,200	12
15	55.5	55,600	55,600	62.5	55,100	55,100	15
20	43.5	38,400	38,500	54.0	37,900	37,900	20
25	26.5	25,600	25,600	43.5	25,300	25,300	25
30				31.0	18,100	18,100	30
Min.Bm Ang/Cap	0 (27.5)	18,400	18,400	0 (34.5)	13,700	13,700	Min.Bm Ang/Cap
Load Radius (Ft.)	50 Ft.			57 Ft.			Load Radius (Ft.)
	∠°	360°	Over Rear	∠°	360°	Over Rear	
10	75.0	67,500	67,500	77.0	43,800	43,800	10
12	73.0	61,200	61,200	75.0	43,800	43,800	12
15	69.0	53,400	53,400	72.0	42,100	42,100	15
20	62.5	37,300	37,300	66.5	34,300	34,300	20
25	55.5	24,900	24,900	60.5	24,600	24,600	25
30	48.0	17,900	17,900	54.5	17,600	17,600	30
35	39.0	13,200	13,200	47.5	13,100	13,100	35
40	27.5	9,800	10,000	40.0	9,600	9,900	40
45				30.5	7,200	7,600	45
50				16.0	5,200	5,700	50
Min.Bm Ang/Cap	0 (44.5)	7,400	7,800	0 (51.5)	4,700	5,200	Min.Bm Ang/Cap

Note: Refer To Page 5 For "Capacity Deductions For Auxiliary Load Handling Equipment".
 ∠ Loaded Boom Angle In Degrees.
 () Reference Radius For Min. Boom Angle Capacities (Shown in Parenthesis) Are In Feet.

Rated Lifting Capacities In Pounds Fully Extended Outriggers See Set Up Note 2

4,700 lbs.

FULL EXTENSION

MAIN BOOM "B"

Load Radius (Ft.)	33 Ft.			40 Ft.			50 Ft.			Load Radius (Ft.)
	∠°	360°	Over Rear	∠°	360°	Over Rear	∠°	360°	Over Rear	
9	68.0	80,000	80,000							9
10	66.0	72,300	72,300	70.5	72,300	72,300	74.5	35,000	35,000	10
12	62.0	65,500	65,500	67.5	65,200	65,200	72.5	35,000	35,000	12
15	55.5	55,600	55,600	62.5	55,100	55,100	68.5	35,000	35,000	15
20	43.5	38,400	38,500	54.0	37,900	37,900	62.5	35,000	35,000	20
25	26.5	25,600	25,600	43.5	25,300	25,600	55.5	26,800	26,800	25
30				31.0	19,000	19,000	47.5	19,600	19,600	30
35							39.0	14,900	14,900	35
40							27.5	11,500	11,600	40
Min.Bm Ang/Cap	0 (27.5)	18,400	18,400	0 (34.5)	13,500	13,500	0 (44.5)	9,100	9,200	Min.Bm Ang/Cap
Load Radius (Ft.)	60 Ft.			70 Ft.			80 Ft.			Load Radius (Ft.)
	∠°	360°	Over Rear	∠°	360°	Over Rear	∠°	360°	Over Rear	
10	77.5	35,000	35,000							10
12	75.5	35,000	35,000							12
15	72.5	35,000	35,000	75.5	35,000	35,000				15
20	67.5	35,000	35,000	71.5	35,000	35,000				20
25	62.0	27,000	27,000	67.0	27,100	27,100	71.0	26,400	26,400	25
30	56.5	19,800	19,800	62.5	19,900	19,900	66.5	20,000	20,000	30
35	50.0	15,200	15,200	57.5	15,300	15,300	62.5	15,400	15,400	35
40	43.5	11,800	11,900	52.0	12,000	12,100	58.0	12,100	12,200	40
45	35.0	9,300	9,500	46.5	9,400	9,700	53.5	9,500	9,800	45
50	25.0	7,300	7,700	40.0	7,500	7,900	48.5	7,600	8,100	50
55				32.5	6,000	6,400	43.5	6,100	6,600	55
60				23.0	4,800	5,200	37.5	5,000	5,400	60
65							30.5	4,000	4,400	65
70							21.5	3,100	3,600	70
Min.Bm Ang/Cap	0 (54.5)	5,900	6,300	0 (64.5)	3,800	4,300	0 (74.5)	2,500	2,900	Min.Bm Ang/Cap
Load Radius (Ft.)	90 Ft.			100 Ft.			105 Ft.			Load Radius (Ft.)
	∠°	360°	Over Rear	∠°	360°	Over Rear	∠°	360°	Over Rear	
20	77.0	27,400	27,400							20
25	73.5	23,500	23,500	76.0	21,000	21,000		17,500	17,500	25
30	70.0	20,100	20,100	73.0	18,700	18,700	74.0	17,500	17,500	30
35	66.5	15,500	15,500	69.5	15,600	15,600	71.0	15,600	15,600	35
40	62.5	12,200	12,300	66.5	12,200	12,300	68.0	12,200	12,400	40
45	58.5	9,600	9,900	63.0	9,600	10,000	64.5	9,700	10,000	45
50	54.5	7,700	8,100	59.5	7,800	8,200	61.5	7,800	8,200	50
55	50.5	6,200	6,700	55.5	6,300	6,800	58.0	6,300	6,800	55
60	46.0	5,000	5,500	52.0	5,100	5,600	54.5	5,100	5,600	60
65	41.0	4,100	4,500	48.0	4,100	4,600	50.5	4,100	4,600	65
70	35.5	3,200	3,700	43.5	3,300	3,800	47.0	3,300	3,800	70
75	29.0	2,500	3,000	39.0	2,600	3,100	42.5	2,600	3,100	75
80	20.5	1,900	2,400	34.0	2,000	2,500	38.0	2,000	2,500	80
Min.Bm Ang/Cap	16.5 (81.8)			30.5 (82.6)			35.0 (83.3)			Min.Bm Ang/Cap

Note: Refer To Page 5 For "Capacity Deductions For Auxiliary Load Handling Equipment".
 ∠ Loaded Boom Angle In Degrees.
 () Reference Radius For Min. Boom Angle Capacities (Shown in Parenthesis) Are In Feet.

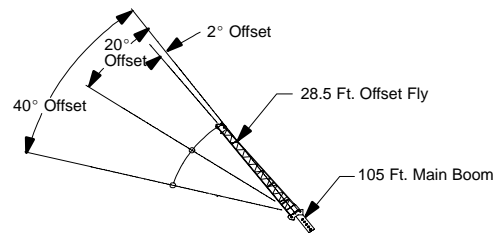
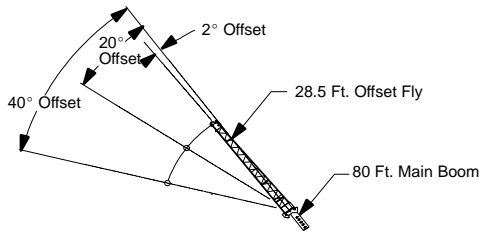

Rated Lifting Capacities In Pounds Fully Extended Outriggers See Set Up Note 2

FULL EXTENSION 4700 lbs.

Load Radius (Ft.)	2° Offset		20° Offset		40° Offset		Load Radius (Ft.)
	∠°	360°	∠°	360°	∠°	360°	
25	77.0	15,200					25
30	74.5	13,900					30
35	72.0	11,900	76.0	8,700			35
40	69.0	11,000	73.0	8,100	77.0	6,100	40
45	66.0	10,300	70.0	7,600	74.0	5,800	45
50	63.0	8,900	67.0	7,100	71.0	5,600	50
55	59.5	7,300	64.0	6,700	67.5	5,400	55
60	56.5	6,100	61.0	6,400	64.0	5,300	60
65	53.0	5,000	57.5	5,600	60.5	5,100	65
70	49.0	4,200	53.5	4,600	57.0	5,000	70
75	45.0	3,500	49.5	3,800	52.5	4,100	75
80	41.0	2,900	45.0	3,200	47.5	3,400	80
85	36.5	2,300	40.5	2,600	42.0	2,700	85
90	31.0	1,900	35.0	2,000			90
95	25.0	1,400	28.0	1,600			95

Rated Lifting Capacities In Pounds Fully Extended Outriggers See Set Up Note 2

FULL EXTENSION 4700 lbs.

Load Radius (Ft.)	2° Offset		20° Offset		40° Offset		Load Radius (Ft.)
	∠°	360°	∠°	360°	∠°	360°	
35	76.5	9,000					35
40	74.5	9,000	78.0*	7,900			40
45	72.5	8,800	76.0	7,500			45
50	70.0	7,900	73.5	7,200	76.5	5,700	50
55	67.5	7,000	71.0	6,600	74.0	5,500	55
60	65.0	5,800	69.0	6,100	71.5	5,400	60
65	62.5	4,800	66.0	5,400	69.5	5,200	65
70	59.5	3,900	63.5	4,500	66.5	4,900	70
75	56.5	3,200	60.5	3,700	63.5	4,100	75
80	54.0	2,600	57.5	3,000	60.5	3,400	80
85	51.0	2,100	54.5	2,400	57.0	2,700	85
90			51.5	1,900	53.5	2,200	90
95			48.0	1,500	50.0	1,700	95

WARNING

Do Not Lower 28.5 Ft. Offset Fly In Working Position Below 47° Main Boom Angle Unless Main Boom Length Is 74 Ft. Or Less, Since Loss Of Stability Will Occur Causing A Tipping Condition.

Note: Refer To Page 5 For "Capacity Deductions For Auxiliary Load Handling Equipment".
 ∠ Loaded Boom Angle In Degrees. * This Capacity Based On Maximum Obtainable Boom Angle.

Note: Refer To Page 5 For "Capacity Deductions For Auxiliary Load Handling Equipment".
 ∠ Loaded Boom Angle In Degrees. * This Capacity Based On Maximum Obtainable Boom Angle.

Note: Refer To Page 5 For "Capacity Deductions For Auxiliary Load Handling Equipment".
 ∠ Loaded Boom Angle In Degrees.

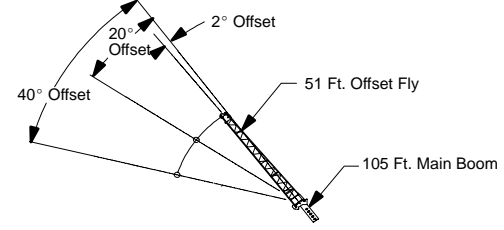
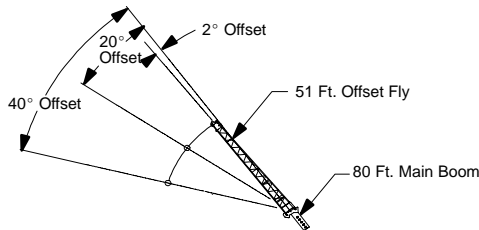

Rated Lifting Capacities In Pounds Fully Extended Outriggers See Set Up Note 2

FULL EXTENSION 4700 lbs.

Load Radius (Ft.)	2° Offset		20° Offset		40° Offset		Load Radius (Ft.)
	∠°	360°	∠°	360°	∠°	360°	
35	76.0	7,400					35
40	74.0	6,700					40
45	71.5	6,100	78.0*	4,200			45
50	69.5	5,600	76.0	3,900			50
55	67.0	5,100	73.5	3,700			55
60	64.5	4,700	71.0	3,500	77.0	2,700	60
65	62.0	4,300	68.5	3,300	74.5	2,600	65
70	59.5	4,000	66.0	3,100	72.0	2,500	70
75	57.0	3,800	63.0	2,900	69.0	2,400	75
80	54.0	3,500	60.5	2,800	66.0	2,300	80
85	51.0	2,900	57.5	2,700	62.5	2,300	85
90	47.5	2,500	54.5	2,600	59.5	2,200	90
95	44.5	2,000	51.0	2,500	55.5	2,200	95
100	41.0	1,700	47.5	2,000	51.5	2,200	100
105			43.0	1,700	47.0	1,900	105
110			38.5	1,300	41.0	1,400	110

Rated Lifting Capacities In Pounds Fully Extended Outriggers See Set Up Note 2

FULL EXTENSION 4700 lbs.

Load Radius (Ft.)	2° Offset		20° Offset		40° Offset		Load Radius (Ft.)
	∠°	360°	∠°	360°	∠°	360°	
40	77.5	5,800					40
45	75.5	5,700					45
50	74.0	5,400					50
55	72.0	5,100	77.5	3,700			55
60	70.5	4,800	75.5	3,500			60
65	68.5	4,500	73.5	3,400			65
70	66.5	4,200	71.5	3,200	76.5	2,500	70
75	64.0	3,700	69.5	3,100	74.5	2,400	75
80	62.0	3,100	67.5	2,900	72.5	2,400	80
85	59.5	2,500	65.5	2,800	70.5	2,300	85
90	57.0	2,100	63.5	2,700	68.0	2,300	90
95			60.5	2,200	65.5	2,200	95
100			58.0	1,800	63.0	2,200	100
105					60.0	1,800	105
110					57.0	1,400	110

WARNING

Do Not Lower 51 Ft. Offset Fly In Working Position Below 55.5° Main Boom Angle Unless Main Boom Length Is 67 Ft. Or Less, Since Loss Of Stability Will Occur Causing A Tipping Condition.

Note: Refer To Page 5 For "Capacity Deductions For Auxiliary Load Handling Equipment".
 ∠ Loaded Boom Angle In Degrees. * This Capacity Based On Maximum Obtainable Boom Angle.

Note: Refer To Page 5 For "Capacity Deductions For Auxiliary Load Handling Equipment".
 ∠ Loaded Boom Angle In Degrees. * This Capacity Based On Maximum Obtainable Boom Angle.

Note: Refer To Page 5 For "Capacity Deductions For Auxiliary Load Handling Equipment".
 ∠ Loaded Boom Angle In Degrees. * This Capacity Based On Maximum Obtainable Boom Angle.

WORKING RANGE DIAGRAM

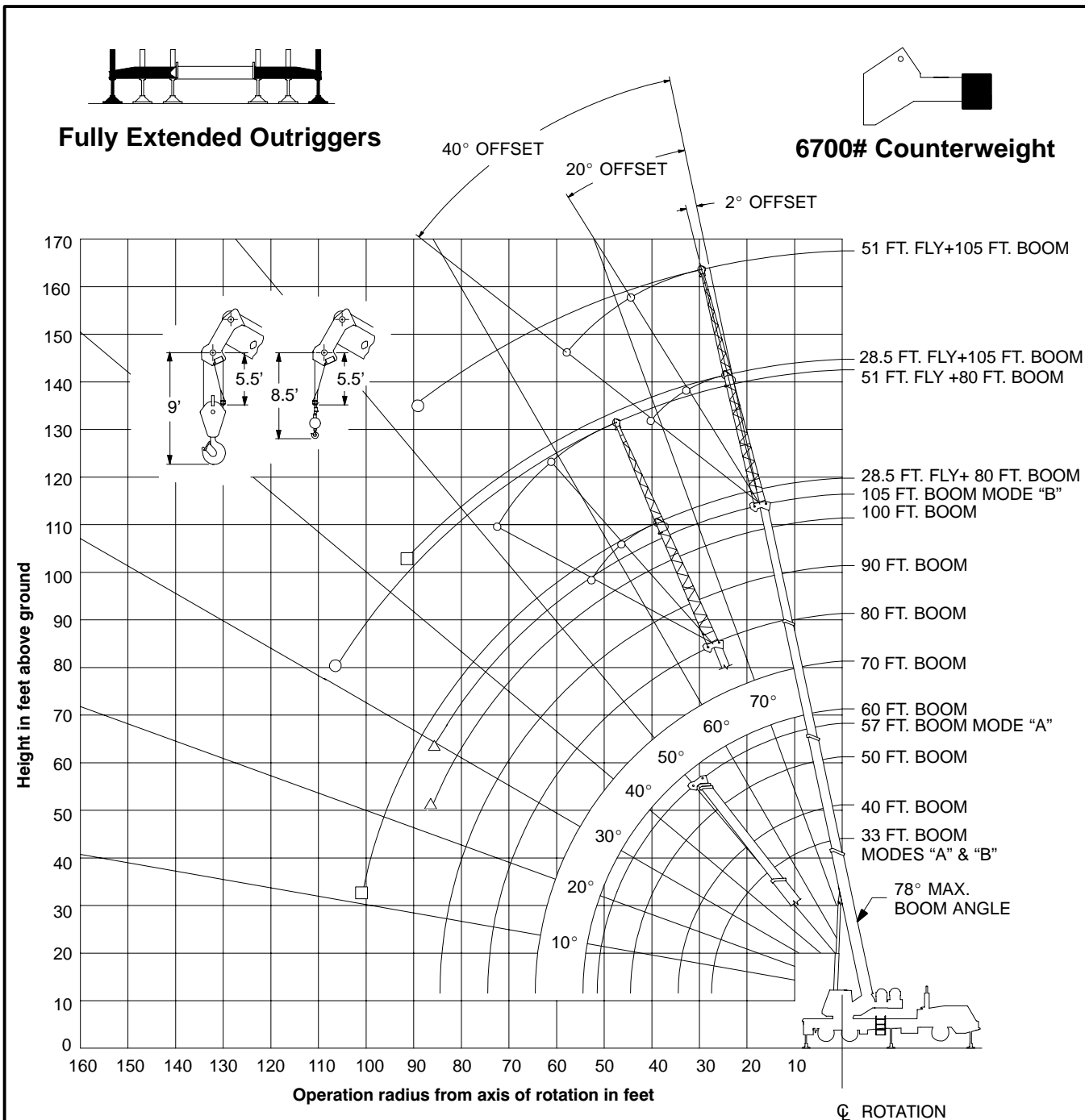

- Denotes Main Boom + 51' Offset Fly-Boom Mode "B"
- Denotes Main Boom + 28.5' Offset Fly-Boom Mode "B"
- △ Denotes Main Boom -Boom Mode "B"

Note: Boom and fly geometry shown are for unloaded condition and crane standing level on firm supporting surface. Boom deflection, subsequent radius and boom angle change must be accounted for when applying load to hook.

WARNING

Do Not Lower The Boom Below The Minimum Boom Angle For No Load Stability As Shown In The Lift Charts For The Boom Lengths Given. Loss Of Stability Will Occur Causing A Tipping Condition.

Rated Lifting Capacities
In Pounds
Fully Extended Outriggers
See Set Up Note 2



6,700 lbs.

FULL EXTENSION

MAIN BOOM "A"

Load Radius (Ft.)	33 Ft.			40 Ft.			Load Radius (Ft.)
	∠ °	360°	Over Rear	∠ °	360°	Over Rear	
9	68.0	80,000	80,000				9
10	66.0	72,300	72,300	70.5	72,300	72,300	10
12	62.0	65,800	65,800	67.5	65,500	65,500	12
15	55.5	55,800	55,800	62.5	55,600	55,600	15
20	43.5	40,700	40,800	54.0	40,200	40,200	20
25	26.5	27,200	27,200	44.0	27,000	27,000	25
30				31.0	19,400	19,400	30
Min.Bm Ang./Cap	0 (27.5)	18,400	18,400	0 (34.5)	14,100	14,100	Min.Bm Ang./Cap
Load Radius (Ft.)	50 Ft.			57 Ft.			Load Radius (Ft.)
	∠ °	360°	Over Rear	∠ °	360°	Over Rear	
10	75.0	67,500	67,500	77.0	43,800	43,800	10
12	73.0	61,200	61,200	75.0	43,800	43,800	12
15	69.0	53,400	53,400	72.0	42,100	42,100	15
20	62.5	39,600	39,600	66.5	34,300	34,300	20
25	55.5	26,600	26,600	60.5	26,300	26,300	25
30	48.0	19,100	19,100	54.5	18,900	18,900	30
35	39.0	14,300	14,300	47.5	14,200	14,200	35
40	27.5	10,900	10,900	40.0	10,800	10,800	40
45				30.5	8,200	8,300	45
50				16.0	6,100	6,400	50
Min.Bm Ang./Cap	0 (44.5)	8,400	8,600	0 (51.5)	5,500	5,900	Min.Bm Ang./Cap

Note: Refer To Page 5 For "Capacity Deductions For Auxiliary Load Handling Equipment".
∠ Loaded Boom Angle In Degrees.
() Reference Radius For Min. Boom Angle Capacities (Shown in Parenthesis) Are In Feet.

Rated Lifting Capacities
In Pounds
Fully Extended Outriggers
See Set Up Note 2



6,700 lbs.

FULL EXTENSION

MAIN BOOM "B"

Load Radius (Ft.)	33 Ft.			40 Ft.			50 Ft.			Load Radius (Ft.)
	∠ °	360°	Over Rear	∠ °	360°	Over Rear	∠ °	360°	Over Rear	
9	68.0	80,000	80,000							9
10	66.0	72,300	72,300	70.5	35,000	35,000	74.5	35,000	35,000	10
12	62.0	65,800	65,800	67.5	35,000	35,000	72.5	35,000	35,000	12
15	55.5	55,800	55,800	62.5	35,000	35,000	68.5	35,000	35,000	15
20	43.5	40,700	40,800	54.0	35,000	35,000	62.5	35,000	35,000	20
25	26.5	27,200	27,200	43.5	27,900	27,900	55.5	28,400	28,400	25
30				31.0	20,300	20,300	47.5	20,900	20,900	30
35							39.0	15,900	15,900	35
40							27.5	12,500	12,500	40
Min.Bm Ang./Cap	0 (27.5)	18,400	18,400	0 (34.5)	13,500	13,500	0 (44.5)	9,200	9,200	Min.Bm Ang./Cap
Load Radius (Ft.)	60 Ft.			70 Ft.			80 Ft.			Load Radius (Ft.)
	∠ °	360°	Over Rear	∠ °	360°	Over Rear	∠ °	360°	Over Rear	
10	77.5	35,000	35,000							10
12	75.5	35,000	35,000							12
15	72.5	35,000	35,000	75.5	35,000	35,000				15
20	67.5	35,000	35,000	71.5	35,000	35,000	74.5	30,700	30,700	20
25	62.0	28,600	28,600	67.0	28,700	28,700	71.0	26,400	26,400	25
30	56.5	21,100	21,100	62.5	21,200	21,200	67.0	21,300	21,300	30
35	50.0	16,300	16,300	57.5	16,400	16,400	62.5	16,500	16,500	35
40	43.5	12,800	12,800	52.0	13,000	13,000	58.0	13,100	13,100	40
45	35.5	10,300	10,300	46.5	10,400	10,500	53.5	10,500	10,600	45
50	25.0	8,200	8,400	40.0	8,400	8,600	48.5	8,500	8,800	50
55				32.5	6,800	7,000	43.5	6,900	7,200	55
60				23.0	5,500	5,800	37.5	5,700	6,000	60
65							30.5	4,600	4,900	65
70							22.0	3,700	4,000	70
Min.Bm Ang./Cap	0 (54.5)	6,500	6,500	0 (64.5)	4,500	4,600	0 (74.5)	3,000	3,300	Min.Bm Ang./Cap
Load Radius (Ft.)	90 Ft.			100 Ft.			105 Ft.			Load Radius (Ft.)
	∠ °	360°	Over Rear	∠ °	360°	Over Rear	∠ °	360°	Over Rear	
20	77.0	27,400	27,400							20
25	73.5	23,500	23,500	76.0	21,000	21,000	76.5	17,500	17,500	25
30	70.0	20,500	20,500	73.0	18,700	18,700	74.0	17,500	17,500	30
35	66.5	16,600	16,600	70.0	16,500	16,500	71.0	15,700	15,700	35
40	62.5	13,200	13,200	66.5	13,200	13,200	68.0	13,300	13,300	40
45	59.0	10,600	10,700	63.0	10,600	10,700	64.5	10,700	10,800	45
50	55.0	8,600	8,800	59.5	8,700	8,900	61.5	8,700	8,900	50
55	50.5	7,000	7,300	56.0	7,100	7,400	58.0	7,100	7,400	55
60	46.0	5,700	6,100	52.0	5,800	6,100	54.5	5,800	6,200	60
65	41.0	4,700	5,000	48.0	4,800	5,100	51.0	4,800	5,200	65
70	35.5	3,800	4,200	44.0	3,900	4,200	47.0	3,900	4,300	70
75	29.0	3,100	3,400	39.0	3,200	3,500	43.0	3,200	3,500	75
80	20.5	2,400	2,800	34.0	2,500	2,900	38.5	2,500	2,900	80
85				28.0	2,000	2,300	33.0	2,000	2,300	85
Min.Bm Ang./Cap	0 (84.5)	1,900	2,200	23.5 (87.7)			29.5 (88.2)			Min.Bm Ang./Cap

Note: Refer To Page 5 For "Capacity Deductions For Auxiliary Load Handling Equipment".
∠ Loaded Boom Angle In Degrees.
() Reference Radius For Min. Boom Angle Capacities (Shown In Parenthesis) Are In Feet.

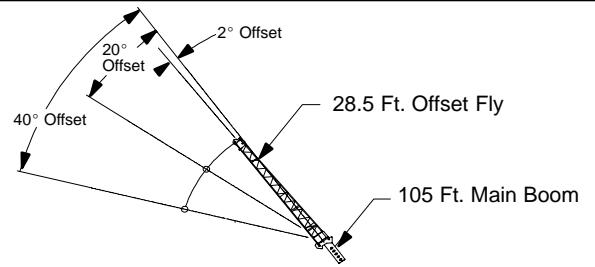
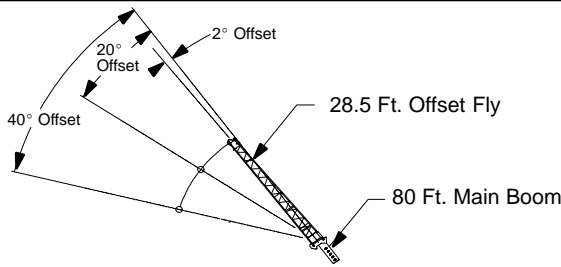

Rated Lifting Capacities In Pounds Fully Extended Outriggers See Set Up Note 2							
Load Radius (Ft.)	2° Offset		20° Offset		40° Offset		Load Radius (Ft.)
	∠	360°	∠	360°	∠	360°	
	25	77.0	15,200				
30	74.5	13,900					30
35	72.0	11,900	76.0	8,700			35
40	69.0	11,000	73.0	8,100	77.0	6,100	40
45	66.0	10,300	70.0	7,600	74.0	5,800	45
50	63.0	9,600	67.0	7,100	71.0	5,600	50
55	60.0	8,100	64.0	6,700	67.5	5,400	55
60	56.5	6,800	61.0	6,400	64.0	5,300	60
65	53.0	5,700	57.5	6,000	60.5	5,100	65
70	49.5	4,800	53.5	5,200	57.0	5,000	70
75	45.5	4,000	49.5	4,400	52.5	4,700	75
80	41.0	3,400	45.5	3,700	48.0	3,900	80
85	36.5	2,800	40.5	3,000	42.5	3,200	85
90	31.5	2,300	35.0	2,500			90
95	25.0	1,900	28.5	2,000			95
100	16.5	1,500	18.0	1,500			100

WARNING
Do Not Lower 28.5 Ft. Offset Fly In Working Position Below 11.5° Main Boom Angle Unless Main Boom Length Is 79 Ft. Or Less, Since Loss Of Stability Will Occur Causing A Tipping Condition.

Rated Lifting Capacities In Pounds Fully Extended Outriggers See Set Up Note 2							
Load Radius (Ft.)	2° Offset		20° Offset		40° Offset		Load Radius (Ft.)
	∠	360°	∠	360°	∠	360°	
	35	76.5	9,000				
40	74.5	9,000	78.0°	7,900			40
45	72.5	8,800	76.0	7,500			45
50	70.0	7,900	73.5	7,200	76.5	5,700	50
55	67.5	7,200	71.0	6,600	74.0	5,500	55
60	65.5	6,500	69.0	6,100	71.5	5,400	60
65	62.5	5,400	66.5	5,700	69.5	5,200	65
70	60.0	4,500	63.5	5,100	66.5	5,000	70
75	57.0	3,800	61.0	4,200	64.0	4,600	75
80	54.0	3,100	58.0	3,500	60.5	3,900	80
85	51.0	2,500	54.5	2,900	57.5	3,200	85
90	48.0	2,000	51.5	2,400	54.0	2,600	90
95	44.5	1,600	48.0	1,900	50.5	2,100	95
100			44.5	1,500	46.5	1,600	100

WARNING
Do Not Lower 28.5 Ft. Offset Fly In Working Position Below 43.5° Main Boom Angle Unless Main Boom Length Is 79 Ft. Or Less, Since Loss Of Stability Will Occur Causing A Tipping Condition.

Note: Refer To Page 6 For "Capacity Deductions For Auxiliary Load Handling Equipment."
∠ Loaded Boom Angle In Degrees. * This Capacity Based On Maximum Obtainable Boom Angle.

Note: Refer To Page 6 For "Capacity Deductions For Auxiliary Load Handling Equipment."
∠ Loaded Boom Angle In Degrees. * This Capacity Based On Maximum Obtainable Boom Angle.

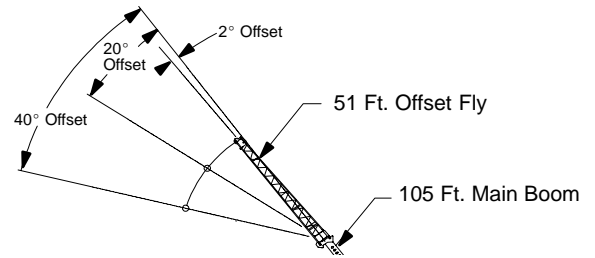
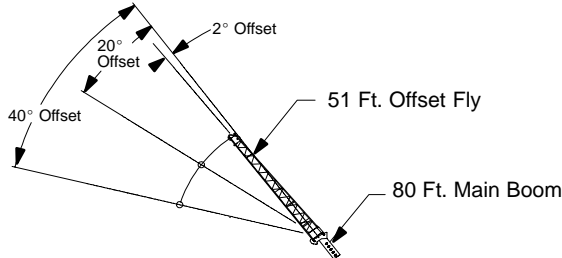

Rated Lifting Capacities In Pounds Fully Extended Outriggers See Set Up Note 2							
Load Radius (Ft.)	2° Offset		20° Offset		40° Offset		Load Radius (Ft.)
	∠	360°	∠	360°	∠	360°	
	35	76.0	7,400				
40	74.0	6,700					40
45	71.5	6,100	78.0°	4,200			45
50	69.5	5,600	76.0	3,900			50
55	67.0	5,100	73.5	3,700			55
60	64.5	4,700	71.0	3,500	77.0	2,700	60
65	62.0	4,300	68.5	3,300	74.5	2,600	65
70	59.5	4,000	66.0	3,100	72.0	2,500	70
75	57.0	3,800	63.0	2,900	69.0	2,400	75
80	54.0	3,500	60.5	2,800	66.0	2,300	80
85	51.0	3,300	57.5	2,700	62.5	2,300	85
90	48.0	2,900	54.5	2,600	59.5	2,200	90
95	44.5	2,400	51.0	2,500	55.5	2,200	95
100	41.0	2,000	47.5	2,400	51.5	2,200	100
105	37.0	1,700	43.5	2,000	47.0	2,100	105
110	33.0	1,400	39.0	1,600	41.5	1,800	110
115			33.5	1,300			115

WARNING
Do Not Lower 51 Ft. Offset Fly In Working Position Below 31.5° Main Boom Angle Unless Main Boom Length Is 71 Ft. Or Less, Since Loss Of Stability Will Occur Causing A Tipping Condition.

Rated Lifting Capacities In Pounds Fully Extended Outriggers See Set Up Note 2							
Load Radius (Ft.)	2° Offset		20° Offset		40° Offset		Load Radius (Ft.)
	∠	360°	∠	360°	∠	360°	
	40	77.5	5,800				
45	75.5	5,700					45
50	74.0	5,400					50
55	72.0	5,100	77.5	3,700			55
60	70.5	4,800	75.5	3,500			60
65	68.5	4,500	73.5	3,400			65
70	66.5	4,200	71.5	3,200	76.5	2,500	70
75	64.5	3,900	69.5	3,100	74.5	2,400	75
80	62.0	3,600	67.5	2,900	72.5	2,400	80
85	60.0	3,000	65.5	2,800	70.5	2,300	85
90	57.5	2,500	63.5	2,700	68.0	2,300	90
95	55.0	2,100	61.0	2,600	65.5	2,200	95
100			58.5	2,200	63.0	2,200	100
105			55.5	1,800	60.5	2,200	105
110					57.5	1,700	110
115					54.0	1,400	115

WARNING
Do Not Lower 51 Ft. Offset Fly In Working Position Below 52.5° Main Boom Angle Unless Main Boom Length Is 71 Ft. Or Less, Since Loss Of Stability Will Occur Causing A Tipping Condition.

Note: Refer To Page 6 For "Capacity Deductions For Auxiliary Load Handling Equipment."
∠ Loaded Boom Angle In Degrees. * This Capacity Based On Maximum Obtainable Boom Angle.

Note: Refer To Page 6 For "Capacity Deductions For Auxiliary Load Handling Equipment."
∠ Loaded Boom Angle In Degrees. * This Capacity Based On Maximum Obtainable Boom Angle.

Specifications

Telescopic Boom Truck Crane

HTC-8640 Heavy Lift 40-ton (36.29 metric tons)

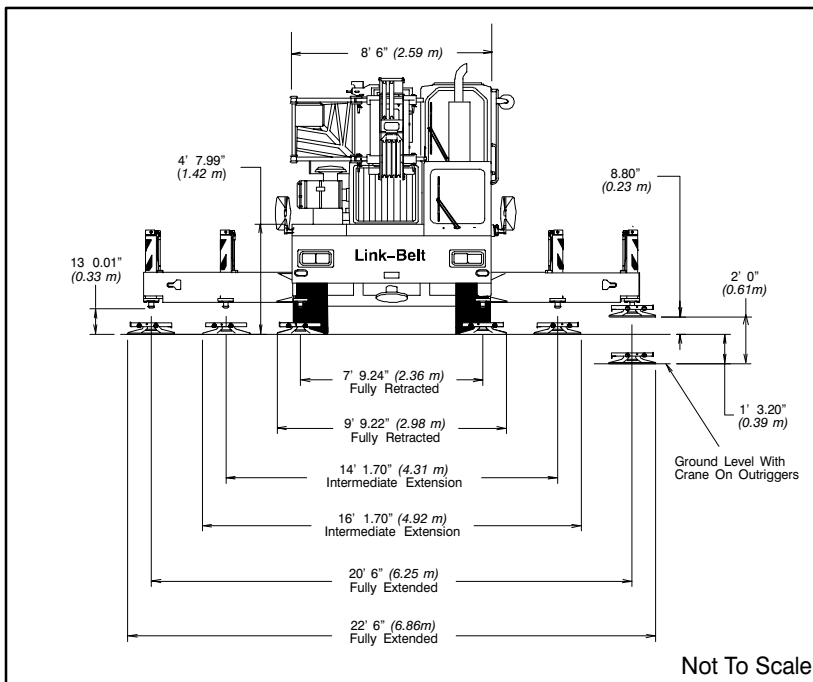
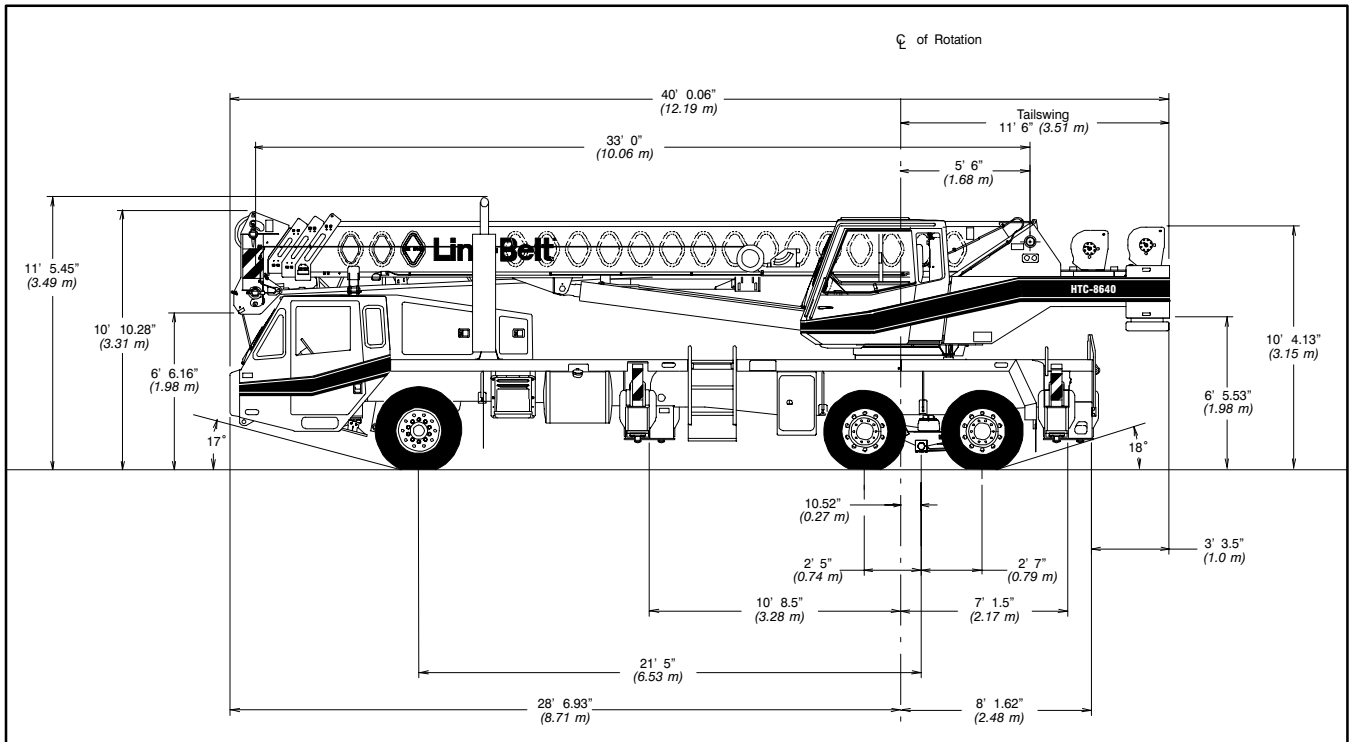

General Dimension	feet	meters
Turning radius – wall to wall	44' 2"	13.46
Turning radius – curb to curb	39' 6"	14.44
Ground clearance	13"	.33
Tailswing	11' 6"	3.51

Upper Structure

■ Boom

Patented Design

- Boom side plates have diamond shaped impressions for superior strength to weight ratio and 100,000 p.s.i. (689.5 MPa) steel angle chords for lateral stiffness.
- Boom telescope sections are supported by top, bottom and adjustable side wear shoes to prevent metal to metal contact.

Boom

- 33' – 105' (10.06 – 32.00 m) four-section full power boom.
- Two mode boom extension
- The basic mode is the full power, synchronized mode of telescoping all sections proportionally to 105' (32.00 m).
- The exclusive "A-max" mode (or mode 'A') extends only the inner mid section to 57' (17.37 m) offering increased capacities for in-close, maximum capacity picks.
- Mechanical Boom Angle Indicator

Boom Head

- Four 16.5" (0.42 m) root diameter nylon sheaves to handle up to eight parts of wire rope.
- Easily removable wire rope guards
- Rope dead end lugs provided on each side of boom head.
- Boom head designed for quick reeve of hook block.

Boom Elevation

- One Link-Belt designed hydraulic cylinder with holding valve and bushing in each end.
- Hand control for controlling boom elevation from -3° to +78°.

Optional Auxiliary Lifting Sheave

- Single 16.5" (0.42 m) root diameter nylon sheave with removable wire rope guard, mounted to boom.
- Use with one or two parts of line off the optional front winch.
- Does not affect erection of fly or use of main head sheaves for multiple reeving.

Optional

- 25-ton (22.7 mt) quick reeve hook block.
- 40-ton (36.3 mt) quick reeve hook block.
- 8.5-ton (7.7 mt) hook ball.
- Boom floodlight.

■ Fly

Optional

- 28.5' (8.69 m) one-piece lattice fly, stowable, offsettable to 2°, 20° and 40°.
- 28.5' – 51' (8.69 – 15.54 m) two-piece (bi-fold) fly, stowable, offsettable to 2°, 20° and 40°.

■ Cab and Controls

Environmental Ultra-Cab™

- Laminated fibrous composite material; isolated from sound with acoustical fabric insulation.

- Windows are tinted and tempered safety glass.
- Sliding rear and right side windows and swing-up roof window for maximum visibility and ventilation.
- Slide-by-door opens to 3' (0.91 m) width.
- Six-way adjustable seat for maximum operator comfort.
- Hand-held outrigger controls and sight level bubble located in cab.
- Diesel cab heater
- Pull-out Cabwalk™
- Audible swing alarm
- Fire extinguisher
- 12-volt accessory outlet
- Electric windshield wiper
- Windshield washer
- Top hatch window wiper
- Circulating fan
- Warning horn
- Cup holder
- Sun screen
- Hand throttle
- Mirrors
- Dome light

Optional

- Amber strobe light
- Amber rotating beacon
- Hydraulic heater
- Air conditioning

Controls

Hydraulic controls (joy-stick type) for:

- Swing
- Optional auxiliary winch
- Main winch
- Boom hoist

Foot controls for:

- Boom telescope
- Swing brake
- Engine throttle

Optional

- Auxiliary winch
- Single axis controls

Cab Instrumentation

Cornerpost-mounted gauges for:

- Hydraulic oil temperature
- Audio/Visual warning system
- Tachometer
- Voltmeter
- Water temperature
- Oil pressure
- Fuel

■ Rated Capacity Limiter

- **Microguard 434** Graphic audio-visual warning system built into dash with anti-two block and function limiters.

Operating data available includes:

- Machine configuration.
- Boom length
- Head height
- Allowed load
- % of allowed load
- Boom angle
- Radius of load
- Actual load

Pre-settable alarms include:

- Maximum and minimum boom angles.
- Maximum tip height.
- Maximum boom length.
- Swing left/right positions.
- Operator defined area alarm is standard.
- Anti-two block weight designed for quick reeve of hook block.

Optional

- **Internal RCL light bar:** Visually informs operator when crane is approaching maximum load capacity with a series of three lights; green, yellow and red.
- **External RCL light bar:** Visually informs ground crew when crane is approaching maximum load capacity kickouts and pre-settable alarms with a series of three lights; green, yellow and red.

■ Swing

- Bi-directional hydraulic swing motor mounted to a planetary reducer for 360° continuous smooth swing at 2.8 r.p.m.
- **Swing park brake** – 360°, electric over hydraulic (spring applied, hydraulic released) multi-disc brake mounted on the speed reducer. Operated by toggle switch in overhead control console.
- **Swing brake** – 360°, foot operated, hydraulic applied disc brake mounted on the speed reducer.
- **Swing lock** – Standard; two position travel lock operated from the operator's cab.
- **Counterweight**
 - Standard – Bolted to upper structure frame. 9,700 lbs. (4 400 kg) consisting of 4,700 lbs. (2 132 kg) base counterweight and 5,000 lbs. (2 268 kg) of removable counterweights.

Optional

- 360° swing lock. Meets New York City requirements.

■ Hydraulic System

Main Pump

- One gear pump with a total of four sections.
- Combined pump capacity of 131 gpm (488 lpm).
- Powered by carrier engine through power take-off (PTO).
- Spline type pump disconnect, mechanically activated pump disconnect engaged / disengaged from carrier cab.
- Maximum system operating pressure is 3,350 psi (23 098 kPa).
- O-ring face seals technology used throughout with hydraulic oil cooler standard.

Steering / Fifth Outrigger Pump

- Single gear type pump, 6 gpm (23 lpm). Powered by carrier engine through front gear housing.
- Max. pump operating pressure is 2,000 psi (13 790 kPa). Reservoir – 131 gallon (507.2 L) capacity. One diffuser for deaeration.

Filtration

- One 10-micron filter located inside hydraulic reservoir.
- Accessible for easy replacement.

Control valves

- Five separate pilot operated control valves allow simultaneous operation of all crane functions.

Load Hoist System

Standard

- 2M main winch with grooved lagging.
- Two-speed motor and automatic brake.
- Power up/down mode of operation.

- Bi-directional piston-type hydraulic motor driven through planetary reduction unit for positive control under all load conditions.
- Asynchronous parallel double crossover grooved drums minimize rope harmonic motion.
- Pressure compensated winch circuit provides balanced oil flow to both winches for smooth, simultaneous operation.
- Rotation resistant wire rope.
- Drum rotation indicators.

Line Pulls and Speeds

- Maximum available line pull 13,010 lbs. (5 901 kg) and maximum line speed of 480 f.p.m. (146 m/min) on 10.63" (0.27 m) root diameter grooved drum.

Optional

- 2M auxiliary winch with two-speed motor, automatic brake, and winch function lock-out. Power up/down modes.
- Hoist drum cable followers.
- Third wrap indicators.

Carrier

Type

- 8' 6" (2.59 m) wide, 257" (6.53 m) wheel-base. 6 x 4 drive – standard.

Frame

- 100,000 p.s.i. (689.5 MPa) steel, double walled construction with integral 100,000 p.s.i. steel outrigger boxes.

Optional

- Carrier mounted storage boxes.
- Pintle hook.
- Electric and air connections for trailers.

Axles

Front

- Single, 83.22" (2.11 m) track.

Rear

- Tandem, 73.41" (1.86 m) track. 6.17 to 1.0 ratio with interaxle differential with lockout (6.64:1 ratio with automatic transmission).

Suspension

Front axle

- Leaf spring suspension.

Rear axle

- Air-ride, bogie-beam type, suspension.

Wheels

Standard

- Hub piloted aluminum disc.

Tires

Standard Front

- 425/65R22.5 (Load range "L") single tubeless radials.

Standard Rear

- 12R22.5 (Load range "H") dual tubeless radials.

Brakes

Service

- Full air brakes on all wheel ends with automatic slack adjusters. Dual circuit with modulated emergency brakes.
 - Front – 16.5 x 6 S-Cam brakes.
 - Rear – 16.5 x 7 S-Cam brakes.

Parking/Emergency

- One spring set, air released chamber per rear axle end.
- Parking brake applied with valve mounted on carrier dash.

- Emergency brakes apply automatically when air drops below 40 psi (275.8 kPa) in both systems.

Steering

- Sheppard rack and pinion design.

Optional

- Remote drive and steer.

Transmission

Standard

- Eaton RTX-11609B; 9 speeds forward, 2 reverse.

Optional

- Automatic Allison MD 3066, 65:1 high, 3.49:1 low.

Auxiliary

- Eaton 2A-92, two speed– High: 1.0:1 Low: 2.3:1 (with automatic transmission only).

Electrical

- Two 12-volt batteries provide 12-volt starting. 160-amp alternator.
- 1,400 cold cranking amps available.
- 12-volt operating system,

Lights

- Four dual beam sealed headlights.
- Front, side, and rear directional signals.
- Stop, tail and license plate lights.
- Rear and side clearance lights.
- Hazard warning lights.

Outriggers

- Three position operation capability.
- Four hydraulic, telescoping beam and jack outriggers.
- Vertical jack cylinders equipped with integral holding valve.
- Beams extend to 20' 6" (6.25 m) centerline-to-centerline and retract to within 8' 6" (2.59 m) overall width.
- Equipped with stowable, lightweight 24" (0.61 m) diameter aluminum floats.
- Standard fifth outrigger, 16" (0.41 m) self storing steel pad is operable from ground or operator's cab.
- Hand-held controls and sight level bubble located on carrier deck.

Confined Area Lifting Capacities (CALC™) System

- The crane is operational in one of the three outriggers positions and operational in confined areas in two positions (intermediate and full retraction). The three outrigger positions are:

- Full extension – 20' 6" (6.25 m).
- Intermediate position – 14' 1.70" (4.31 m).
- Full retraction – 7' 9.24" (2.36 m).
- Capacities are available with the outrigger beams in the intermediate and full retraction positions.
- When the outrigger position levers (located on the outrigger beams) are engaged, the operator can set the crane in the intermediate or full retraction outrigger position without having to leave the cab.

Carrier Cab

- One-man cab of laminated fibrous composite material acoustical insulation with cloth covering.

Equipped with:

- Air-ride, six-way adjustable operator's seat
- Four-way adjustable tilting and lockable steering wheel
- Door and windows locks
- Left-hand and right-hand rear view mirrors
- Sliding right-hand and rear tinted windows
- Roll up/down left-hand tinted window
- Desiccant-type air dryer
- Steps to upper, lower cab and rear carrier
- 120-volt electric engine block heater
- Back-up warning alarm
- Tow hooks and shackles
- Aluminum fenders with ground control outriggers
- Electric windshield wiper and washer.
- Travel lights
- Fire extinguisher
- 36,000 BTU heater
- Dome light
- Mud flaps

Optional

- Rotating Beacon
- Amber Strobe Light
- Air conditioning

Cab instrumentation

- Illuminated instrument panel speedometer.
- Tachometer
- Fuel gauge
- Oil pressure gauge
- Turn signal indicator
- Water temperature gauge
- Front and rear air pressure gauges
- Audio/visual warning system
- Automotive type ignition
- Hourmeter
- Fuses
- Odometer
- Voltmeter

Carrier Speeds *(Manual Transmission – Standard tires)*

Gear	High					Low					Hi Rev.	Lo Rev.	Low Rev. @700 rpm	Low @700 rpm
	8	7	6	5	4	3	2	1	Low	Rev.	Rev.	Low Rev.	Low	
Ratio	0.73	1.00	1.38	1.95	2.79	3.83	5.28	7.47	12.57	3.43	13.14	13.14	12.57	
Speed	mph	57.92	42.28	30.64	21.68	15.15	11.04	8.01	5.66	3.36	12.33	3.22	1.07	1.12
	km/hr.	93.42	68.19	49.42	35.00	24.44	17.81	12.92	9.13	5.42	19.89	5.42	1.72	1.64

Engine

Engine – standard	Cummins ISL 330 with Jake Brake
Cylinders – cycle	6 / 4
Bore	4.49" (114 mm)
Stroke	5.69" (145 mm)
Displacement	540 cu. in. (8 849 cm ³)
Maximum brake hp.	345 @ 1,900 rpm; 330 @ 2,100 rpm
Peak torque	1,150 ft. lbs. (1 559.2 J) @ 1,300 – 1,400 rpm
Electric system	12-volt neg. ground / 12 volt starting
Fuel capacity	75 gallons (284 L)
Alternator	12 volt, 160 amps
Crankcase capacity	29 qts. (28 L)

Axle Loads

Base machine with standard 33' – 105' (10.06 – 32.00 m) four-section boom, 2M main winch with 2-speed hoisting and power up/down, 450' (137 m), 5/8" (19 mm) wire rope, 8 x 4, 8.5' (2.59 m) carrier with Cummins ISL 330 Engine, 75 gal. (284 L) fuel, aluminum fenders and 9,700 lb. (4 400 kg.) counterweight.	G.V.W. ¹		Upper Facing Front			
	lbs.	kg.	Front Axle		Rear Axle	
			lbs.	kg.	lbs.	kg.
	62,185	28 207	16,677	7 565	45,508	20 642
Left side carrier aluminum storage box	57	26	14	6	43	20
Right side carrier aluminum storage box	57	26	14	6	43	20
Six-speed automatic transmission and two-speed auxiliary transmission with engine brake	576	261	223	101	353	160
Air conditioning – Carrier cab	124	56	135	61	-11	-5
Pintle hook w/air and electrical hook-ups	32	15	-9	-4	41	19
Driver in carrier cab	200	91	236	107	-36	-16
Cab heater assembly (hydraulic)	110	50	-8	-4	118	5
Air conditioning – Operator cab	315	143	-35	-16	350	159
Rear winch roller	77	35	-31	-14	108	49
Front winches with two speeds and 450' (137.2 m) of wire rope	312	141	-93	-43	405	184
Front winch roller	77	35	-22	-10	99	45
Remove rear winch rope (450')	-365	-166	161	73	-526	-239
Remove front winch rope (450')	-365	-166	120	54	-485	-220
360 degree Mechanical House Lock	60	27	-2	-1	62	28
Fly brackets to boom base section for fly options	116	53	62	28	54	24
28.5' (8.69 m) offsettable fly w/ATB weight (stowed)	1,184	537	839	381	345	156
28.5' – 51' (8.69 – 15.54 m) offsettable fly w/ATB weight (stowed)	1,757	797	1,141	518	616	279
Floodlight to front of boom base section	10	5	13	6	-3	-1
25-ton (22.7 mt) hook block stowed behind bumper (3-sheaves)	670	304	784	356	-114	-52
40-ton (36.3 mt) hook block stowed behind bumper (4-sheaves)	780	354	913	414	-133	-60
Hookball to front bumper	360	163	421	191	-61	-28
Auxiliary arm w/ATB switch to boomhead	110	50	169	69	-59	-20

¹ Adjust gross vehicle weight & axle loading according to component weight. Note: All weights are ± 3%

Axle	Max. Load @ 65 mph. (105 km/h)
Front	22,700 lbs. (10 297 kg) – aluminum disc wheels
Rear	47,250 lbs. (21 432 kg) – aluminum disc wheels

Lifting Capacities

Telescopic Hydraulic Truck Crane

HTC-8640 *Heavy Lift* 40-ton (36.3 metric ton)

Boom and fly capacities for this machine are listed by the following sections:

Fully Extended Outriggers

- Working Range Diagram (9,700 lbs. Counterweight)
- 33 to 57 ft. main boom capacities, A-max mode
- 33 to 105 ft. main boom capacities, Basic Mode "B"
- 28.5 ft. offset fly capacities, Basic Mode "B"
- 28.5 to 51 ft. two-piece offset fly capacities, Basic mode "B"

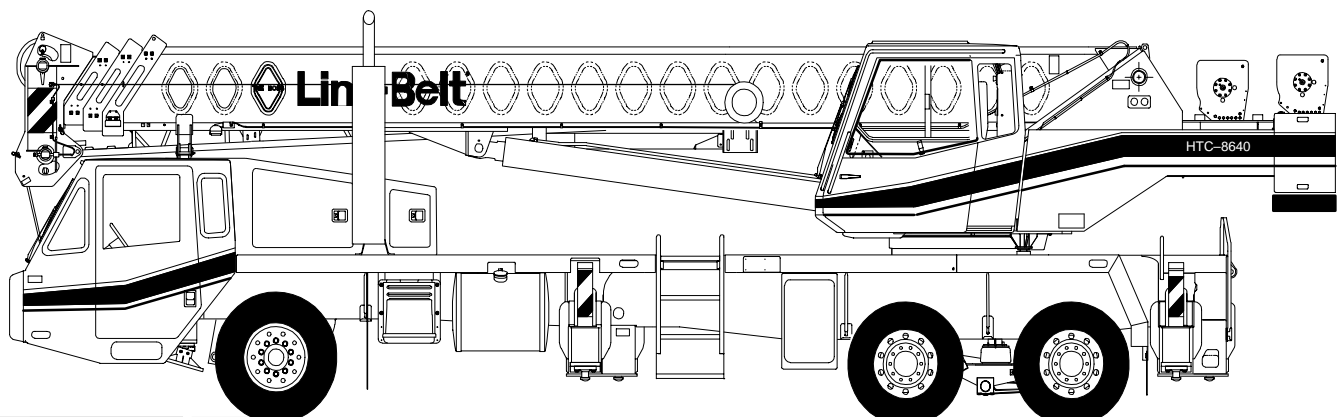

CAUTION: This material is supplied for reference use only. Operator must refer to in-cab Crane Rating Manual to determine allowable machine lifting capacities and operating procedures.

Table Of Contents

Page	Contents
3-4	Operating Instructions
5	Tire Inflation
5	Pontoon Loadings
5	Boom Mode "A" and "B"
5	Winch Performance
5	Wire Rope Capacity
5	Hydraulic Circuit Pressure Settings
5	Working Areas
5	Capacity Deductions for Auxiliary Load Handling Equipment

Fully Extended Outriggers

6	Working Range Diagram, 9,700 lbs. Counterweight
7-8	Lifting Capacities, 9,700 lbs. Counterweight



WARNING

READ AND UNDERSTAND THE OPERATOR'S AND SAFETY MANUALS AND THE FOLLOWING INSTRUCTIONS AND RATED LIFTING CAPACITIES BEFORE OPERATING THE CRANE. OPERATION WHICH DOES NOT FOLLOW THESE INSTRUCTIONS MAY RESULT IN AN ACCIDENT.

OPERATING INSTRUCTIONS

GENERAL:

- 1 . Rated lifting capacities in pounds as shown on lift charts pertain to this crane as originally manufactured and normally equipped. Modifications to the crane or use of optional equipment other than that specified can result in a reduction of capacity.
- 2 . Construction equipment can be dangerous if improperly operated or maintained. Operation and maintenance of this crane must be in compliance with the information in the Operator's, Parts, and Safety Manuals supplied with this crane. If these manuals are missing, order replacements through the distributor.
- 3 . The operator and other personnel associated with this crane shall read and fully understand the latest applicable American National Standards ASME B30.5 safety standards for cranes.
- 4 . The rated lifting capacities are based on crane standing level on firm supporting surface.

SET UP:

- 1 . The crane shall be leveled on a firm supporting surface. Depending on the nature of the supporting surface, it may be necessary to have structural supports under the outrigger pontoons or tires to spread the load to a larger bearing surface.
- 2 . When making lifts on outriggers, all tires must be free of supporting surface. All outrigger beams must be extended to the same length; fully retracted, intermediate extended, or fully extended. The front bumper outrigger must be properly extended.
- 3 . When making lifts on tires, they must be inflated to the recommended pressure. (See Operation note 20 and Tire Inflation.)
- 4 . Before swinging boom to over side position on tires, boom sections must be fully retracted not exceeding a 72° boom angle.
- 5 . For required parts of line, see Wire Rope Capacity and Winch Performance.
- 6 . Before setting up on intermediate outriggers, retracted outriggers, or tires, refer to Working Range Diagrams and rated lifting capacities to determine allowable crane configurations.

OPERATION:

- 1 . Rated lifting capacities at rated radius shall not be exceeded. Do not tip the crane to determine allowable loads. For concrete bucket operation, weight of bucket and load shall not exceed 80% of rated lifting capacities. For clamshell bucket operation, weight of bucket and bucket contents is restricted to a maximum weight of 6,000 pounds or 80% of rated lifting capacity, whichever is less. For magnet operation, weight of magnet and load is restricted to a maximum weight of 6,000 pounds or 80% of rated lifting capacity, whichever is less. For clamshell and magnet operation, maximum boom length is restricted to 50 ft. and the boom angle is restricted to a minimum of 35 degrees. Lifts with either fly erected is prohibited for both clam and magnet operation.
- 2 . Rated lifting capacities shown on fully extended outriggers do not exceed 85% of the tipping loads. Rated lifting capacities shown on intermediate extended or fully retracted outriggers are determined by the formula, rated load = (tipping load – 0.1 X load factor)/1.25. Rated lifting capacities shown on tires do not exceed 75% of the tipping loads. Tipping loads are determined by SAE crane stability test code J-765.
- 3 . Rated lifting capacities in the shaded areas are based on structural strength or hydraulic limitations and have been tested to meet minimum requirements of SAE J-1063 cantilevered boom crane structures—method of test. The rated lifting capacities in non-shaded areas are based on stability ratings. Some capacities are limited by a maximum obtainable 78° boom angle.
- 4 . Rated lifting capacities include the weight of the hook ball/block, slings, bucket, magnet and auxiliary lifting devices. Their weights must be subtracted from the listed rated capacity to obtain the net load which can be lifted. Rated lifting capacities include the deduct for either fly stowed on the base of the boom. For deducts of either fly erected, but not used, see Capacity Deductions For Auxiliary Load Handling Equipment.

- 5 . Rated lifting capacities are based on freely suspended loads. No attempt shall be made to move a load horizontally on the ground in any direction.
- 6 . Rated lifting capacities are for lift crane service only.
- 7 . Do not operate at radii or boom lengths (minimum or maximum) where capacities are not listed. At these positions, the crane can tip or cause boom failure.
- 8 . The maximum loads which can be telescoped are not definable because of variation in loadings and crane maintenance, but it is permissible to attempt retraction and extension within the limits of the applicable load rating chart.
- 9 . For main boom capacities when either boom length or radius or both are between values listed, proceed as follows:
 - a. For boom lengths not listed, use rating for next longer boom length or next shorter boom length, whichever is smaller.
 - b. For load radii not listed, use rating for next larger radius.
- 10 . The user shall operate at reduced ratings to allow for adverse job conditions, such as: soft or uneven ground, out of level conditions, wind, side loads, pendulum action, jerking or sudden stopping of loads, hazardous conditions, experience of personnel, traveling with loads, electrical wires, etc. Side load on boom or fly is dangerous and shall be avoided.
- 11 . Rated lifting capacities do not account for wind on suspended load or boom. Rated capacities and boom length shall be appropriately reduced as wind velocity approaches or exceeds 20 mph.
- 12 . When making lifts with auxiliary head machinery, the effective length of the boom increases by 2 ft.
- 13 . Power sections of boom must be extended in accordance with boom mode "A" or "B". In boom mode "B" all power sections must be extended or retracted equally.
- 14 . The least stable rated working area depends on the configuration of the crane set up.
- 15 . Rated lifting capacities are based on correct reeving. Deduction must be made for excessive reeving. Any reeving over minimum required (see Wire Rope Capacity) is considered excessive and must be accounted for when making lifts. Use Working Range Diagram to estimate the extra feet of rope then deduct 1 lb. for each extra foot of wire rope before attempting to lift a load.
- 16 . The loaded boom angle combined with the boom length give only an approximation of the operating radius. The boom angle, before loading, should be greater to account for deflection. For main boom capacities, the loaded boom angle is for reference only. For fly capacities, the load radius is for reference only.
- 17 . For fly capacities with main boom length less than 105 ft. and greater than 80 ft., the rated capacities are determined by the boom angle using the 105 ft. boom and fly chart. For angles not shown use the next lower boom angle to determine the rated capacity.
- 18 . For fly capacities with main boom length less than 80 ft., the rated capacities are determined by the boom angle using the 80 ft. boom and fly chart. For angles not shown use the next lower boom angle to determine the rated capacity.
- 19 . The 33 ft. boom length structural lifting capacities are based on boom fully retracted. If the boom is not fully retracted, do not exceed capacities shown for the 40 ft. boom length.
- 20 . Rated lifting capacities on tires depend on tire capacity, condition of tires, and tire air pressure. On tire capacities require lifting from main boom head only on a smooth and level surface. The boom must be centered over the rear of the crane with two position travel swing lock engaged and the load must be restrained from swinging. Rated lifting capacities on tires are limited to creep and 2.5 mph speed. For correct tire pressure, see Tire Inflation.

DEFINITIONS:

- 1 . Load Radius: Horizontal distance from a projection of the axis of rotation to the supporting surface, before loading, to the center of the vertical hoist line or tackle with load applied.
- 2 . Loaded Boom Angle:  The angle between the boom base section and horizontal with freely suspended load at the rated radius.
- 3 . Working Area: Area measured in a circular arc about the center line of rotation as shown on the Working Area Diagram.
- 4 . Freely Suspended Load: Load hanging free with no direct external force applied except by the hoist line.
- 5 . Side Load: Horizontal side force applied to the lifted load either on the ground or in the air.
- 6 . No Load Stability Limit: The radius or boom angle beyond which it is not permitted to position the boom because the crane can overturn without any load on the hook.
- 7 . Load Factor: Load applied at the boom tip which gives the same moment effect as the boom mass.
- 8 . Creep: Crane movement not exceeding 200 ft. in a 30 minute period and 1 mph maximum speed.

BOOM EXTENSION

Boom Mode "A"
Only inner mid section telescopes

Inner Mid Section
288" Stroke

Base Section

Boom Length (ft.)

33

40

50

57

Boom Mode "B"
Inner mid, outer mid and tip sections telescope simultaneously.

Tip Section
288" Stroke

Outer Mid Section
288" Stroke

Inner Mid Section
288" Stroke

Base Section

Boom Length (ft.)

33

40

50

60

70

80

90

100

105

TIRE INFLATION

Tire Size	Operation	Tire Pressure (psi)
12 R 22.5	Creep	120
	2.5 mph	110

PONTOON LOADINGS

Maximum Pontoon Load:	Maximum Pontoon Ground Bearing Pressure:
61,750 lbs.	137 psi

CAPACITY DEDUCTIONS FOR AUXILIARY LOAD HANDLING EQUIPMENT

Load Handling Equipment:	(lbs.)
Auxiliary Head Attached	100
25-ton quick reeve 3 sheave hook block (see hook block for actual weight)	670
40-ton quick reeve 4 sheave hook block (see hook block for actual weight)	780
8.5-ton hook ball (see hook ball for actual weight)	360
Lifting From Main Boom With:	(lbs.)
28.5 ft. or 51 ft. fly stowed on base (see operation note 4)	0
28.5 ft. offset fly erected but not used	2600
51 ft. offset fly erected but not used	4800
Lifting From 28.5 ft. Offset Fly With:	(lbs.)
22.5 ft. fly tip erected but not used	PROHIBITED
22.5 ft. fly tip stowed on 28.5 ft. offset fly	PROHIBITED

Note: Capacity deductions are for Link-Belt supplied equipment only.

WINCH PERFORMANCE

Wire Rope Layer	Winch Line Pulls		Drum Rope Capacity (ft.)	
	Two Speed Winch		Layer	Total
	Low Speed Available Lbs.*	High Speed Available lbs.		
1	13,010	6,418	77	77
2	11,768	5,805	85	162
3	10,742	5,299	93	255
4	9,881	4,874	101	356
5	9,148	4,513	109	465

*Maximum lifting capacity: Type RB Rope=9,080, Type ZB Rope=11,080

WIRE ROPE CAPACITY

Maximum Lifting Capacities Based On Wire Rope Strength			
Parts of Line	5/8"	5/8"	Notes
	Type RB	Type ZB	
1	9,080	11,080	Capacities shown are in pounds and working loads must not exceed the ratings on the capacity charts in the Crane Rating Manual. Study Operator's Manual for wire rope inspection procedures and single part of line applications.
2	18,160	22,160	
3	27,240	33,240	
4	36,320	44,320	
5	45,400	55,400	
6	54,480	66,480	
7	63,560	77,560	
8	72,640	88,640	
9	81,720	—	
LBCE		DESCRIPTION	
TYPE RB	18 X 19 Rotation Resistant – Compact Strand, High Strength Preformed, Right Regular Lay		
TYPE ZB	36 X 7 Rotation Resistant – Extra Improved Plow Steel – Right Regular Lay		

HYDRAULIC CIRCUIT PRESSURE SETTINGS

Function	Pressure (PSI)
Front And Rear Winch	3100
Outriggers	3000
Boom Hoist	3350
Telescope	3000
Swing	1500
Steering	2000
Bumper Outrigger	650
Pilot Control	500

WORKING AREAS

HTC on Outriggers

HTC on Tires

Note: These Lines Determine The Limiting Position Of Any Load For Operation Within Working Areas Indicated.

WORKING RANGE DIAGRAM

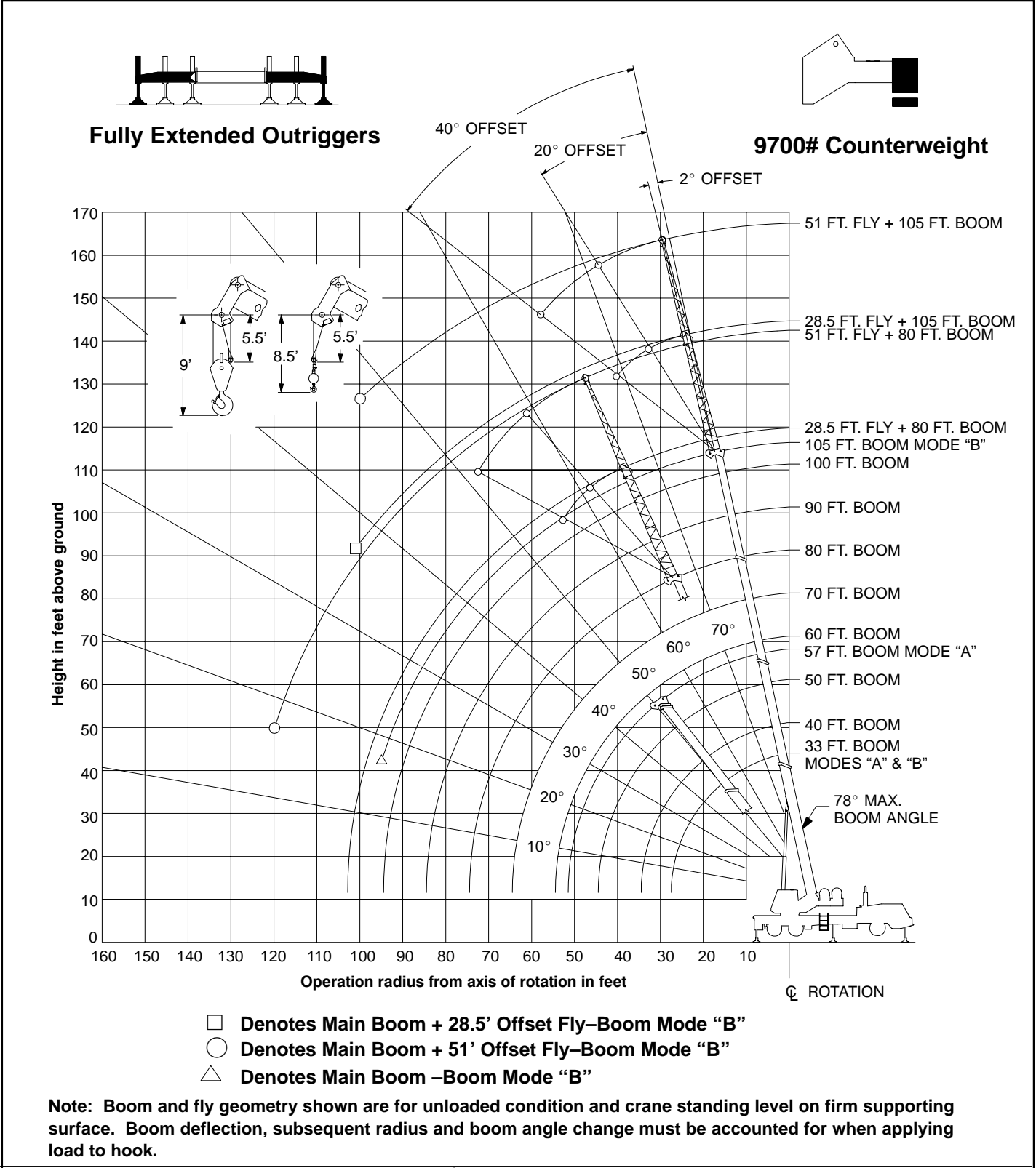

WARNING

Do Not Lower The Boom Below The Minimum Boom Angle For No Load Stability As Shown In The Lift Charts For The Boom Lengths Given. Loss Of Stability Will Occur Causing A Tipping Condition.

Rated Lifting Capacities In Pounds Fully Extended Outriggers See Set Up Note 2

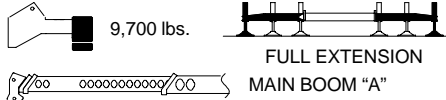

FULL EXTENSION
MAIN BOOM "A"

Load Radius (Ft.)	33 Ft.			40 Ft.		
	∠ °	360°	Over Rear	∠ °	360°	Over Rear
9	68.0	80,000	80,000			
10	66.0	72,300	72,300	70.5	72,300	72,300
12	62.0	65,500	65,500	67.5	65,200	65,200
15	55.5	55,600	55,600	62.5	55,300	55,300
20	43.5	42,200	42,200	54.0	41,900	41,900
25	26.5	29,900	29,900	44.0	29,700	29,700
30				31.0	21,500	21,500
Min. Bm. Ang./Cap	0 (27.5)	18,400	18,400	0 (34.5)	14,100	14,100
Load Radius (Ft.)	50 Ft.			57 Ft.		
	∠ °	360°	Over Rear	∠ °	360°	Over Rear
10	75.0	67,500	67,500	77.0	43,800	43,800
12	73.0	61,200	61,200	75.0	43,800	43,800
15	69.0	53,400	53,400	72.0	42,100	42,100
20	62.5	41,600	41,600	66.5	34,300	34,300
25	55.5	29,300	29,300	61.0	28,700	28,700
30	48.0	21,300	21,300	54.5	21,100	21,100
35	39.0	16,100	16,100	47.5	16,000	16,000
40	27.5	12,400	12,400	40.0	12,300	12,300
45				30.5	9,600	9,600
50				16.0	7,600	7,600
Min. Bm. Ang./Cap	0 (44.5)	9,300	9,300	0 (51.5)	6,900	6,900

Note: Refer To Page 5 For "Capacity Deductions For Auxiliary Load Handling Equipment". ∠ Loaded Boom Angle In Degrees. () Reference Radius For Min. Boom Angle Capacities (Shown in Parenthesis) Are In Feet.

Rated Lifting Capacities In Pounds Fully Extended Outriggers See Set Up Note 2

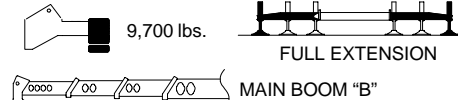

FULL EXTENSION
MAIN BOOM "B"

Load Radius (Ft.)	33 Ft.			40 Ft.			50 Ft.		
	∠ °	360°	Over Rear	∠ °	360°	Over Rear	∠ °	360°	Over Rear
9	68.0	80,000	80,000						
10	66.0	72,300	72,300	70.5	35,000	35,000	74.5	35,000	35,000
12	62.0	65,500	65,500	67.5	35,000	35,000	72.5	35,000	35,000
15	55.5	55,600	55,600	62.5	35,000	35,000	68.5	35,000	35,000
20	43.5	42,200	42,200	54.0	35,000	35,000	62.5	35,000	35,000
25	26.5	29,900	29,900	43.5	30,700	30,700	55.5	31,100	31,100
30				31.0	22,400	22,400	47.5	23,000	23,000
35							39.0	17,700	17,700
40							27.5	14,000	14,000
Min. Bm. Ang./Cap	0 (27.5)	18,400	18,400	0 (34.5)	13,500	13,500	0 (44.5)	9,200	9,200
Load Radius (Ft.)	60 Ft.			70 Ft.			80 Ft.		
	∠ °	360°	Over Rear	∠ °	360°	Over Rear	∠ °	360°	Over Rear
10	77.5	35,000	35,000						
12	75.5	35,000	35,000						
15	72.5	35,000	35,000	75.5	35,000	35,000			
20	67.5	35,000	35,000	71.5	35,000	35,000			
25	62.5	31,400	31,400	67.0	31,500	31,500	74.5	30,700	30,700
30	56.5	23,200	23,200	62.5	23,400	23,400	67.0	22,900	22,900
35	50.5	18,000	18,000	57.5	18,100	18,100	62.5	18,200	18,200
40	43.5	14,300	14,300	52.0	14,500	14,500	58.5	14,600	14,600
45	35.5	11,600	11,600	46.5	11,800	11,800	53.5	11,900	11,900
50	25.0	9,500	9,500	40.0	9,700	9,700	49.0	9,900	9,900
55				33.0	8,100	8,100	43.5	8,200	8,200
60				23.0	6,700	6,700	37.5	6,800	6,900
65							31.0	5,700	5,800
70							22.0	4,700	4,800
Min. Bm. Ang./Cap	0 (54.5)	6,500	6,500	0 (64.5)	4,600	4,600	0 (74.5)	3,300	3,300
Load Radius (Ft.)	90 Ft.			100 Ft.			105 Ft.		
	∠ °	360°	Over Rear	∠ °	360°	Over Rear	∠ °	360°	Over Rear
20	77.0	27,400	27,400						
25	73.5	23,500	23,500	76.0	21,000	21,000	76.5	17,500	17,500
30	70.0	20,500	20,500	73.0	18,700	18,700	74.0	17,500	17,500
35	66.5	18,100	18,100	70.0	16,500	16,500	71.0	15,700	15,700
40	63.0	14,700	14,700	66.5	14,600	14,600	68.0	13,800	13,800
45	59.0	12,000	12,000	63.0	12,000	12,000	65.0	12,100	12,100
50	55.0	9,900	9,900	59.5	10,000	10,000	61.5	10,000	10,000
55	50.5	8,300	8,400	56.0	8,400	8,400	58.5	8,400	8,400
60	46.0	6,900	7,000	52.5	7,000	7,100	55.0	7,000	7,100
65	41.5	5,800	5,900	48.5	5,800	6,000	51.0	5,900	6,000
70	35.5	4,800	4,900	44.0	4,900	5,000	47.0	4,900	5,100
75	29.5	4,000	4,100	39.5	4,100	4,200	43.0	4,100	4,300
80	21.0	3,300	3,400	34.0	3,400	3,500	38.5	3,400	3,600
85				28.0	2,800	2,900	33.5	2,800	3,000
90				20.0	2,200	2,400	27.5	2,200	2,400
95							19.5	1,800	2,000
Min. Bm. Ang./Cap	0 (84.5)	2,300	2,300	0 (94.5)	1,500	1,500	17.0 (96.3)		

Note: Refer To Page 5 For "Capacity Deductions For Auxiliary Load Handling Equipment". ∠ Loaded Boom Angle In Degrees. () Reference Radius For Min. Boom Angle Capacities (Shown In Parenthesis) Are In Feet.

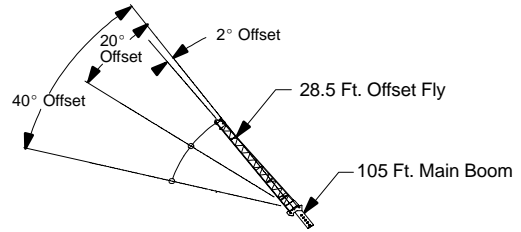
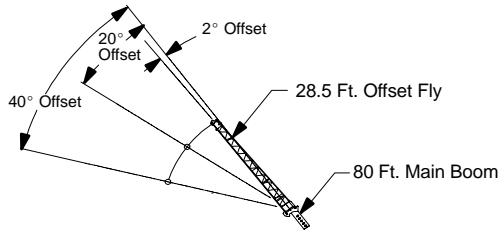

Rated Lifting Capacities In Pounds Fully Extended Outriggers See Set Up Note 2

FULL EXTENSION 9,700 lbs.

Load Radius (Ft.)	2° Offset		20° Offset		40° Offset	
	∠°	360°	∠°	360°	∠°	360°
25	77.0	15,200				
30	74.5	13,900				
35	72.0	11,900	76.0	8,700		
40	69.0	11,000	73.0	8,100	77.0	6,100
45	66.0	10,300	70.0	7,600	74.0	5,800
50	63.0	9,600	67.0	7,100	71.0	5,600
55	60.0	8,900	64.0	6,700	67.5	5,400
60	57.0	7,900	61.0	6,400	64.0	5,300
65	53.5	6,700	57.5	6,000	60.5	5,100
70	49.5	5,800	54.0	5,800	57.0	5,000
75	45.5	4,900	50.0	5,300	52.5	4,900
80	41.5	4,200	45.5	4,500	48.0	4,700
85	37.0	3,600	41.0	3,800	42.5	3,900
90	31.5	3,000	35.5	3,200		
95	25.5	2,500	28.5	2,700		
100	16.5	2,100	18.5	2,200		
Min. Bm. Ang./Cap.	0	1,300	0	1,400	0	1,500

Rated Lifting Capacities In Pounds Fully Extended Outriggers See Set Up Note 2

FULL EXTENSION 9,700 lbs.

Load Radius (Ft.)	2° Offset		20° Offset		40° Offset	
	∠°	360°	∠°	360°	∠°	360°
35	76.5	9,000				
40	74.5	9,000	78.0*	7,900		
45	72.5	8,800	76.0	7,500		
50	70.0	7,900	73.5	7,200	76.5	5,700
55	67.5	7,200	71.0	6,600	74.0	5,500
60	65.5	6,600	69.0	6,100	71.5	5,400
65	63.0	6,100	66.5	5,700	69.5	5,200
70	60.5	5,500	64.0	5,300	66.5	5,000
75	57.5	4,700	61.0	4,900	64.0	4,700
80	54.5	4,000	58.5	4,400	61.0	4,400
85	51.5	3,300	55.0	3,700	58.0	4,000
90	48.5	2,800	52.0	3,100	54.5	3,300
95	45.0	2,300	48.5	2,600	51.0	2,800
100	41.5	1,900	45.0	2,100	47.0	2,300
105	38.0	1,500	41.0	1,700	42.5	1,800

WARNING

Do Not Lower 28.5 Ft. Offset Fly In Working Position Below 37° Main Boom Angle Unless Main Boom Length Is 86 Ft. Or Less, Since Loss Of Stability Will Occur Causing A Tipping Condition.

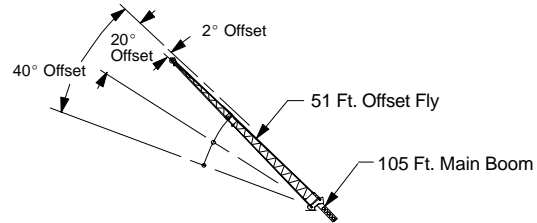
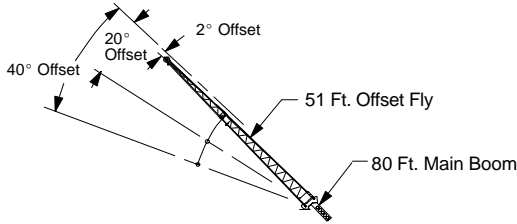

Rated Lifting Capacities In Pounds Fully Extended Outriggers See Set Up Note 2

FULL EXTENSION 9,700 lbs.

Load Radius (Ft.)	2° Offset		20° Offset		40° Offset	
	∠°	360°	∠°	360°	∠°	360°
35	76.0	7,400				
40	74.0	6,700				
45	71.5	6,100	78.0*	4,200		
50	69.5	5,600	76.0	3,900		
55	67.0	5,100	73.5	3,700		
60	64.5	4,700	71.0	3,500	77.0	2,700
65	62.0	4,300	68.5	3,300	74.5	2,600
70	59.5	4,000	66.0	3,100	72.0	2,500
75	57.0	3,800	63.0	2,900	69.0	2,400
80	54.0	3,500	60.5	2,800	66.0	2,300
85	51.0	3,300	57.5	2,700	62.5	2,300
90	48.0	3,100	54.5	2,600	59.5	2,200
95	45.0	2,900	51.0	2,500	55.5	2,200
100	41.5	2,700	47.5	2,400	51.5	2,200
105	37.5	2,300	43.5	2,300	47.0	2,100
110	33.0	2,000	39.0	2,200	41.5	2,100
115	28.0	1,600	33.5	1,800		
120	22.0	1,400	26.5	1,500		

WARNING

Do Not Lower 51 Ft. Offset Fly In Working Position Below 17° Main Boom Angle Unless Main Boom Length Is 78 Ft. Or Less, Since Loss Of Stability Will Occur Causing A Tipping Condition.

Rated Lifting Capacities In Pounds Fully Extended Outriggers See Set Up Note 2

FULL EXTENSION 9,700 lbs.

Load Radius (Ft.)	2° Offset		20° Offset		40° Offset	
	∠°	360°	∠°	360°	∠°	360°
40	77.5	5,800				
45	75.5	5,700				
50	74.0	5,400				
55	72.0	5,100	77.5	3,700		
60	70.5	4,800	75.5	3,500		
65	68.5	4,500	73.5	3,400		
70	66.5	4,200	71.5	3,200	76.5	2,500
75	64.5	3,900	69.5	3,100	74.5	2,400
80	62.0	3,600	67.5	2,900	72.5	2,400
85	60.0	3,300	65.5	2,800	70.5	2,300
90	58.0	3,000	63.5	2,700	68.0	2,300
95	55.5	2,800	61.0	2,600	65.5	2,200
100	53.0	2,300	58.5	2,500	63.0	2,200
105	50.0	1,900	56.0	2,300	60.5	2,200
110			53.5	2,000	57.5	2,100
115			50.5	1,600	54.5	1,900
120					51.0	1,500

WARNING

Do Not Lower 51 Ft. Offset Fly In Working Position Below 47.5° Main Boom Angle Unless Main Boom Length Is 78 Ft. Or Less, Since Loss Of Stability Will Occur Causing A Tipping Condition.

Note: Refer To Page 5 For "Capacity Deductions For Auxiliary Load Handling Equipment". ∠° Loaded Boom Angle In Degrees. * This Capacity Based On Maximum Obtainable Boom Angle.

Note: Refer To Page 5 For "Capacity Deductions For Auxiliary Load Handling Equipment". ∠° Loaded Boom Angle In Degrees. * This Capacity Based On Maximum Obtainable Boom Angle.

Technical Data

Specifications & Capacities

HTC 8640 HL

Telescopic Boom Truck Crane
40 ton (36.29 metric ton)

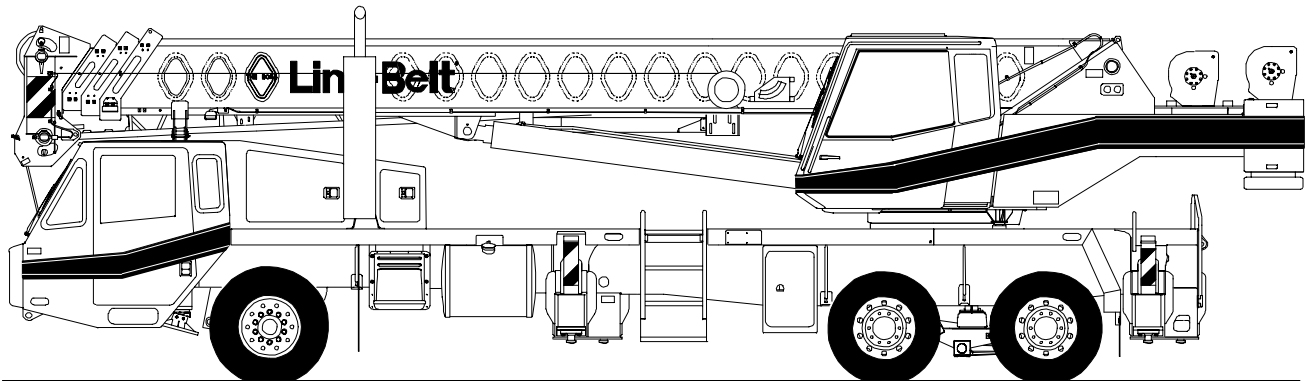

CAUTION: This material is supplied for reference use only. Operator must refer to in-cab Crane Rating Manual and Operator's Manual to determine allowable crane lifting capacities and assembly and operating procedures.

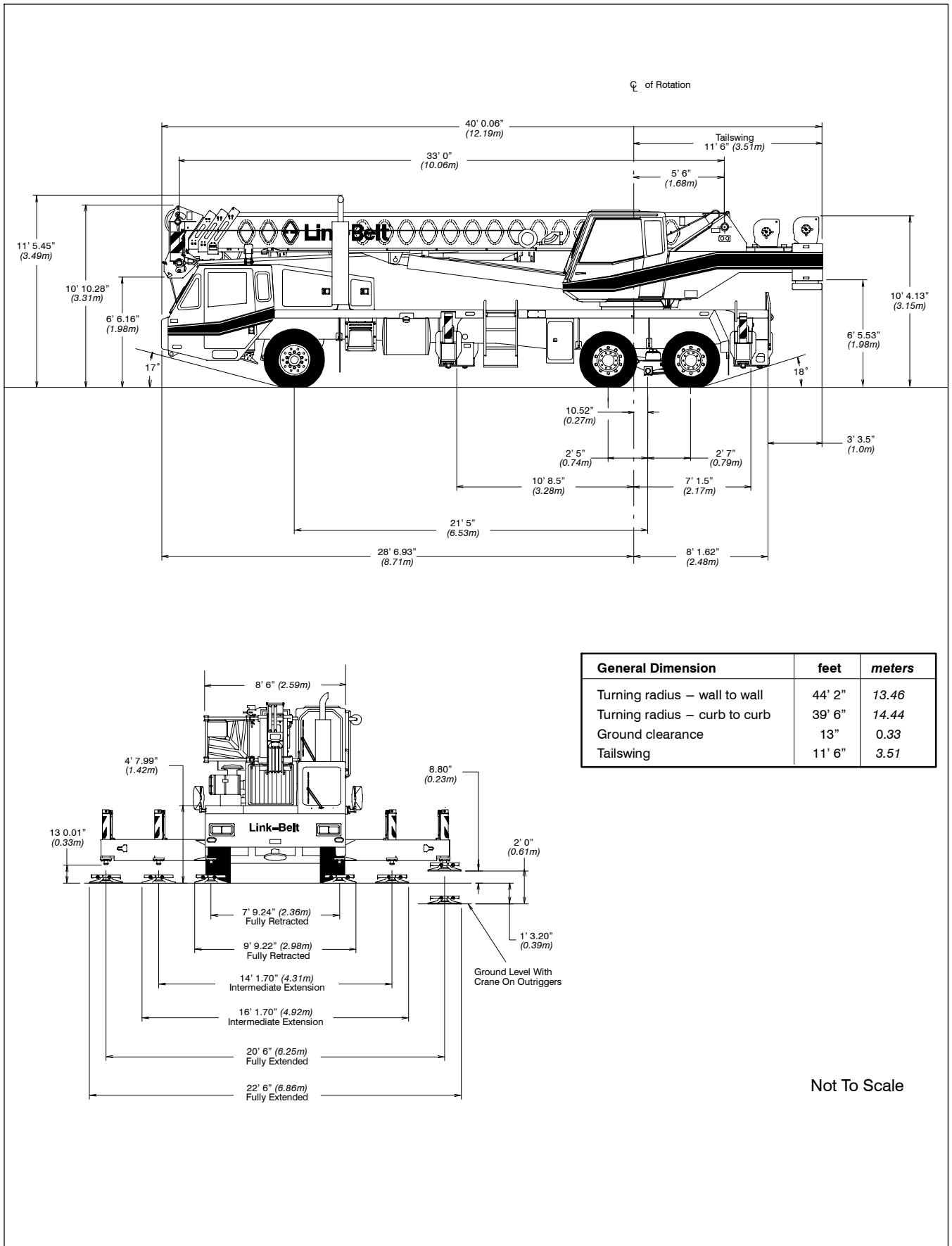

Upper Structure

■ Boom

Patented Design

- Boom side plates have diamond shaped impressions for superior strength to weight ratio and 100,000 psi (689.5mPa) steel angle chords for lateral stiffness
- Boom telescope sections are supported by top, bottom, and adjustable side wear shoes to prevent metal to metal contact

Boom

- 33–105 ft (10.06–32.00m) four–section full power boom
- Two mode boom extension
- The basic mode is the full power, synchronized mode of telescoping all sections proportionally to 105 ft (32.00m)
- The exclusive “**A–max**” mode (or mode ‘A’) extends only the inner mid section to 57 ft (17.37m) offering increased capacities for in–close, maximum capacity picks
- Mechanical boom angle indicator

Boom Head

- Four 16.5 in (0.42m) root diameter nylon sheaves to handle up to eight parts of wire rope
- Easily removable wire rope guards
- Rope dead end lugs provided on each side of boom head
- Boom head designed for quick reeve of hook block

Boom Elevation

- One Link–Belt designed hydraulic cylinder with holding valve and bushing in each end
- Hand control for controlling boom elevation from -3° to $+78^{\circ}$

Optional Auxiliary Lifting Sheave

- Single 16.5 in (0.42m) root diameter nylon sheave with removable wire rope guard, mounted to boom
- Use with one or two parts of line off the optional front winch
- Does not affect erection of fly or use of main head sheaves for multiple reeving

Optional

- 25–ton (22.7mt) quick reeve hook block
- 40–ton (36.3mt) quick reeve hook block
- 8.5–ton (7.7mt) hook ball
- Boom floodlight

■ Fly

Optional

- 28.5 ft (8.69m) one–piece lattice fly, stowable, offsettable to 2° , 20° , and 40°
- 28.5–51 ft (8.69–15.54m) two–piece (bi–fold) fly, stowable, offsettable to 2° , 20° , and 40°

■ Cab and Controls

Environmental Ultra–Cab™

- Laminated fibrous composite material; isolated from sound with acoustical fabric insulation
- Windows are tinted and tempered safety glass
- Sliding rear and right side windows and swing–up roof window for maximum visibility and ventilation
- Slide–by–door opens to 3 ft (0.91m) width
- Six–way adjustable seat for maximum operator comfort
- Hand–held outrigger controls and sight level bubble located in cab
- Diesel cab heater
- Pull–out Cabwalk™
- Audible swing alarm
- Fire extinguisher
- 12–volt accessory outlet
- Electric windshield wiper
- Windshield washer
- Top hatch window wiper
- Circulating fan
- Warning horn
- Cup holder
- Sun screen
- Hand throttle
- Mirrors
- Dome light

Optional

- Amber strobe light
- Amber rotating beacon
- Hydraulic heater
- Air conditioning

Controls

Hydraulic controls (joystick type) for:

- Swing
- Optional auxiliary winch
- Main winch
- Boom hoist

Foot controls for:

- Boom telescope
- Swing brake
- Engine throttle

Optional

- Auxiliary winch
- Single axis controls

Cab Instrumentation

Cornerpost–mounted gauges for:

- Hydraulic oil temperature
- Audio/Visual warning system
- Tachometer
- Voltmeter
- Water temperature
- Oil pressure
- Fuel

■ Rated Capacity Limiter

- **Microguard 434** Graphic audio–visual warning system built into dash with anti–two block and function limiters

Operating data available includes:

- Machine configuration.
- Boom length
- Head height
- Allowed load
- % of allowed load
- Boom angle
- Radius of load
- Actual load

Presettable alarms include:

- Maximum and minimum boom angles
- Maximum tip height
- Maximum boom length
- Swing left/right positions
- Operator defined area alarm is standard
- Anti–two block weight designed for quick reeve of hook block

Optional

- **Internal RCL light bar:** Visually informs operator when crane is approaching maximum load capacity with a series of three lights; green, yellow, and red
- **External RCL light bar:** Visually informs ground crew when crane is approaching maximum load capacity kickouts and presettable alarms with a series of three lights; green, yellow, and red

■ Swing

- Bi–directional hydraulic swing motor mounted to a planetary reducer for 360° continuous smooth swing at 2.8 rpm
- **Swing park brake** – 360° , electric over hydraulic (spring applied, hydraulic released) multi–disc brake mounted on the speed reducer. Operated by toggle switch in overhead control console.
- **Swing brake** – 360° , foot operated, hydraulic applied disc brake mounted on the speed reducer
- **Swing lock** – Standard; two position travel lock operated from the operator’s cab
- **Counterweight**
 - Standard – Bolted to upper structure frame. 9,700 lb (4 400kg) consisting of 4,700 lb (2 132kg) base counterweight and 5,000 lb (2 268kg) of removable counterweights.

Optional

- 360° swing lock. Meets New York City requirements.

Hydraulic System

Main Pump

- One gear pump with a total of four sections
- Combined pump capacity of 131 gpm (488Lpm)
- Powered by carrier engine through power take-off (PTO)
- Spline type pump disconnect, mechanically activated pump disconnect engaged/disengaged from carrier cab
- Maximum system operating pressure is 3,350 psi (23 098kPa)
- O-ring face seals technology used throughout with hydraulic oil cooler standard

Steering / Fifth Outrigger Pump

- Single gear type pump, 6 gpm (23Lpm). Powered by carrier engine through front gear housing

- Max. pump operating pressure is 2,000 psi (13 790kPa). Reservoir – 131 gal (507.2L) capacity. One diffuser for deaeration.

Filtration

- One 10-micron filter located inside hydraulic reservoir
- Accessible for easy replacement

Control valves

- Five separate pilot operated control valves allow simultaneous operation of all crane functions

Load Hoist System

Standard

- 2M main winch with grooved lagging
- Two-speed motor and automatic brake
- Power up/down mode of operation
- Bi-directional piston-type hydraulic motor driven through planetary reduction unit for positive control under all load conditions

- Asynchronous parallel double crossover grooved drums minimize rope harmonic motion
- Pressure compensated winch circuit provides balanced oil flow to both winches for smooth, simultaneous operation
- Rotation resistant wire rope
- Drum rotation indicators

Line Pulls and Speeds

- Maximum available line pull 13,010 lb (5 901kg) and maximum line speed of 480 fpm (146 m/min) on 10.63 in (0.27m) root diameter grooved drum

Optional

- 2M auxiliary winch with two-speed motor, automatic brake, and winch function lockout. Power up/down modes
- Hoist drum cable followers
- Third wrap indicators

Carrier

Type

- 8 ft 6 in (2.59m) wide, 257 in (6.53m) wheelbase. 6 x 4 drive – standard.

Frame

- 100,000 psi (689.5MPa) steel, double walled construction with integral 100,000 psi steel outrigger boxes

Optional

- Carrier mounted storage boxes
- Pintle hook
- Electric and air connections for trailers

Axles

Front

- Single, 83.22 in (2.11m) track

Rear

- Tandem, 73.41 in (1.86m) track. 6.17 to 1.0 ratio with interaxle differential with lockout (6.64:1 ratio with automatic transmission)

Suspension

Front axle

- Leaf spring suspension

Rear axle

- Air-ride, bogie-beam type, suspension

Wheels

Standard

- Hub piloted aluminum disc

Tires

Standard Front

- 425/65R22.5 (Load range “L”) single tubeless radials

Standard Rear

- 12R22.5 (Load range “H”) dual tubeless radials

Brakes

Service

- Full air brakes on all wheel ends with automatic slack adjusters. Dual circuit with modulated emergency brakes.
 - Front – 16.5 x 6 S–Cam brakes
 - Rear – 16.5 x 7 S–Cam brakes

Parking/Emergency

- One spring set, air released chamber per rear axle end
- Parking brake applied with valve mounted on carrier dash
- Emergency brakes apply automatically when air drops below 40 psi (275.8kPa) in both systems

Steering

- Sheppard rack and pinion design

Optional

- Remote drive and steer

Transmission

Standard

- Eaton RTX–11609B; 9 speeds forward, 2 reverse

Optional

- Automatic Allison MD 3066, 65:1 high, 3.49:1 low

Auxiliary

- Eaton 2A–92, two speed– High: 1.0:1 Low: 2.3:1 (with automatic transmission only)

Electrical

- Two 12-volt batteries provide 12-volt starting. 160-amp alternator
- 1,400 cold cranking amps available
- 12-volt operating system

Lights

- Four dual beam sealed headlights
- Front, side, and rear directional signals
- Stop, tail and license plate lights
- Rear and side clearance lights
- Hazard warning lights

Outriggers

- Three position operation capability
- Four hydraulic, telescoping beam and jack outriggers
- Vertical jack cylinders equipped with integral holding valve
- Beams extend to 20 ft 6 in (6.25m) centerline-to-centerline and retract to within 8 ft 6 in (2.59m) overall width
- Equipped with stowable, lightweight 24 in (0.61m) diameter aluminum floats
- Standard fifth outrigger, 16 in (0.41m) self storing steel pad is operable from ground or operator’s cab
- Hand-held controls and sight level bubble located on carrier deck

Confined Area Lifting Capacities (CALC™) System

- The crane is operational in one of the three outriggers positions and operational in confined areas in two positions (intermediate and full retraction). The three outrigger positions are:
 - Full extension – 20 ft 6 in (6.25m)
 - Intermediate position – 14 ft 1.70 in (4.31m)
 - Full retraction – 7 ft 9.24 in (2.36m)
- Capacities are available with the outrigger beams in the intermediate and full retraction positions
- When the outrigger position levers (located on the outrigger beams) are engaged, the operator can set the crane in the intermediate or full retraction outrigger position without having to leave the cab

Carrier Cab

- One-man cab of laminated fibrous composite material acoustical insulation with cloth covering

Equipped with:

- Air-ride, six-way adjustable operator's seat
- Four-way adjustable tilting and lockable steering wheel
- Door and windows locks
- Left-hand and right-hand rear view mirrors
- Sliding right-hand and rear tinted windows
- Roll up/down left-hand tinted window

- Desiccant-type air dryer
- Steps to upper, lower cab and rear carrier
- 120-volt electric engine block heater
- Back-up warning alarm
- Tow hooks and shackles
- Aluminum fenders with ground control outriggers
- Electric windshield wiper and washer
- Travel lights
 - Horn
 - Ashtray
 - Defroster
 - Cruise control
- Fire extinguisher
- 36,000 BTU heater
- Dome light
- Mud flaps

Optional

- Rotating Beacon
- Amber Strobe Light
- Air conditioning

Cab instrumentation

- Illuminated instrument panel speedometer
- Tachometer
- Fuel gauge
- Oil pressure gauge
- Turn signal indicator
- Water temperature gauge
- Front and rear air pressure gauges
- Audio/visual warning system
- Automotive type ignition
- Hourmeter
- Fuses
- Odometer
- Voltmeter

Carrier Speeds *(Manual Transmission – Standard tires)*

Gear	High				Low					Hi Rev.	Lo Rev.	Low Rev. @700 rpm	Low @700 rpm
	8	7	6	5	4	3	2	1	Low	Rev.	Rev.	Low Rev.	Low
Ratio	0.73	1.00	1.38	1.95	2.79	3.83	5.28	7.47	12.57	3.43	13.14	13.14	12.57
Speed	mph	57.92	42.28	30.64	21.68	15.15	11.04	8.01	5.66	3.36	12.33	3.22	1.07
	km/hr	93.42	68.19	49.42	35.00	24.44	17.81	12.92	9.13	5.42	19.89	5.42	1.64

Engine

Engine – standard	Cummins ISL 330 with Jake Brake
Cylinders – cycle	6 / 4
Bore	4.49 in (114mm)
Stroke	5.69 in (145mm)
Displacement	540 cu. in. (8 849cm ³)
Maximum brake hp.	345 @ 1,900 rpm; 330 @ 2,100 rpm
Peak torque	1,150 ft lb (1 559.2J) @ 1,300 – 1,400 rpm
Electric system	12-volt neg. ground / 12 volt starting
Fuel capacity	75 gallons (284L)
Alternator	12 volt, 160 amps
Crankcase capacity	29 qt (28L)

Axle Loads

Base machine with standard 33–105 ft (10.06 – 32.00m) four section boom, 2M main winch with 2-speed hoisting and power up/down, 450 ft (137m), 5/8 in (19mm) wire rope, 8 x 4, 8.5 ft (2.59m) carrier with Cummins ISL 330 Engine, 75 gal (284L) fuel, aluminum fenders, and 9,700 lb (4 400kg) counterweight.	G.V.W. <input type="checkbox"/>		Upper Facing Front			
	lb	kg	Front Axle		Rear Axle	
			lb	kg	lb	kg
	62,185	28 207	16,677	7 565	45,508	20 642
Left side carrier aluminum storage box	57	26	14	6	43	20
Right side carrier aluminum storage box	57	26	14	6	43	20
Six-speed automatic transmission and two-speed auxiliary transmission with engine brake	576	261	223	101	353	160
Air conditioning – Carrier cab	124	56	135	61	-11	-5
Pintle hook w/air and electrical hook-ups	32	15	-9	-4	41	19
Driver in carrier cab	200	91	236	107	-36	-16
Cab heater assembly (hydraulic)	110	50	-8	-4	118	5
Air conditioning – Operator cab	315	143	-35	-16	350	159
Rear winch roller	77	35	-31	-14	108	49
Front winches with two speeds and 450 ft (137.2m) of wire rope	312	141	-93	-43	405	184
Front winch roller	77	35	-22	-10	99	45
Remove rear winch rope (450 ft)	-365	-166	161	73	-526	-239
Remove front winch rope (450 ft)	-365	-166	120	54	-485	-220
360° Mechanical House Lock	60	27	-2	-1	62	28
Fly brackets to boom base section for fly options	116	53	62	28	54	24
28.5 ft (8.69m) offsettable fly w/ATB weight (stowed)	1,184	537	839	381	345	156
28.5–51 ft (8.69–15.54m) offsettable fly w/ATB weight (stowed)	1,757	797	1,141	518	616	279
Floodlight to front of boom base section	10	5	13	6	-3	-1
25-ton (22.7mt) hook block stowed behind bumper (3-sheaves)	670	304	784	356	-114	-52
40-ton (36.3mt) hook block stowed behind bumper (4-sheaves)	780	354	913	414	-133	-60
Hookball to front bumper	360	163	421	191	-61	-28
Auxiliary arm w/ATB switch to boomhead	110	50	169	69	-59	-20

Adjust gross vehicle weight & axle loading according to component weight. Note: All weights are ± 3%

Axle	Maximum Load @ 65 mph (105km/h)
Front	22,700 lb (10 297kg) – aluminum disc wheels
Rear	47,250 lb (21 432kg) – aluminum disc wheels



WARNING

READ AND UNDERSTAND THE OPERATOR'S AND SAFETY MANUALS AND THE FOLLOWING INSTRUCTIONS AND RATED LIFTING CAPACITIES BEFORE OPERATING THE CRANE. OPERATION WHICH DOES NOT FOLLOW THESE INSTRUCTIONS MAY RESULT IN AN ACCIDENT.

OPERATING INSTRUCTIONS

GENERAL:

1. Rated lifting capacities in pounds as shown on lift charts pertain to this crane as originally manufactured and normally equipped. Modifications to the crane or use of optional equipment other than that specified can result in a reduction of capacity.
2. Construction equipment can be dangerous if improperly operated or maintained. Operation and maintenance of this crane must be in compliance with the information in the Operator's, Parts, and Safety Manuals supplied with this crane. If these manuals are missing, order replacements through the distributor.
3. The operator and other personnel associated with this crane shall read and fully understand the latest applicable American National Standards ASME B30.5 safety standards for cranes.
4. The rated lifting capacities are based on crane standing level on firm supporting surface.

SET UP:

1. The crane shall be leveled on a firm supporting surface. Depending on the nature of the supporting surface, it may be necessary to have structural supports under the outrigger pontoons or tires to spread the load to a larger bearing surface.
2. When making lifts on outriggers, all tires must be free of supporting surface. All outrigger beams must be extended to the same length; fully retracted, intermediate extended, or fully extended. The front bumper outrigger must be properly extended.
3. When making lifts on tires, they must be inflated to the recommended pressure. (See Operation note 20 and Tire Inflation.)
4. Before swinging boom to over side position on tires, boom sections must be fully retracted not exceeding a 72° boom angle.
5. For required parts of line, see Wire Rope Capacity and Winch Performance.
6. Before setting up on intermediate outriggers, retracted outriggers, or tires, refer to Working Range Diagrams and rated lifting capacities to determine allowable crane configurations.

OPERATION:

1. Rated lifting capacities at rated radius shall not be exceeded. Do not tip the crane to determine allowable loads. For concrete bucket operation, weight of bucket and load shall not exceed 80% of rated lifting capacities. For clamshell bucket operation, weight of bucket and bucket contents is restricted to a maximum weight of 6,000 pounds or 80% of rated lifting capacity, whichever is less. For magnet operation, weight of magnet and load is restricted to a maximum weight of 6,000 pounds or 80% of rated lifting capacity, whichever is less. For clamshell and magnet operation, maximum boom length is restricted to 50 ft and the boom angle is restricted to a minimum of 35 degrees. Lifts with either fly erected is prohibited for both clam and magnet operation.
2. Rated lifting capacities shown on fully extended outriggers do not exceed 85% of the tipping loads. Rated lifting capacities shown on intermediate extended or fully retracted outriggers are determined by the formula, rated load = (tipping load – 0.1 X load factor)/1.25. Rated lifting capacities shown on tires do not exceed 75% of the tipping loads. Tipping loads are determined by SAE crane stability test code J–765.
3. Rated lifting capacities in the shaded areas are based on structural strength or hydraulic limitations and have been tested to meet minimum requirements of SAE J–1063 cantilevered boom crane structures—method of test. The rated lifting capacities in non–shaded areas are based on stability ratings. Some capacities are limited by a maximum obtainable 78° boom angle.
4. Rated lifting capacities include the weight of the hook ball/block, slings, bucket, magnet and auxiliary lifting devices. Their weights must be subtracted from the listed rated capacity to obtain the net load which can be lifted. Rated lifting capacities include the deduct for either fly stowed on the base of the boom. For deducts of either fly erected, but not used, see Capacity Deductions For Auxiliary Load Handling Equipment.

5. Rated lifting capacities are based on freely suspended loads. No attempt shall be made to move a load horizontally on the ground in any direction.
6. Rated lifting capacities are for lift crane service only.
7. Do not operate at radii or boom lengths (minimum or maximum) where capacities are not listed. At these positions, the crane can tip or cause boom failure.
8. The maximum loads which can be telescoped are not definable because of variation in loadings and crane maintenance, but it is permissible to attempt retraction and extension within the limits of the applicable load rating chart.
9. For main boom capacities when either boom length or radius or both are between values listed, proceed as follows:
 - a.. For boom lengths not listed, use rating for next longer boom length or next shorter boom length, whichever is smaller.
 - b.. For load radii not listed, use rating for next larger radius.
10. The user shall operate at reduced ratings to allow for adverse job conditions, such as: soft or uneven ground, out of level conditions, wind, side loads, pendulum action, jerking or sudden stopping of loads, hazardous conditions, experience of personnel, traveling with loads, electrical wires, etc. Side load on boom or fly is dangerous and shall be avoided.
11. Rated lifting capacities do not account for wind on suspended load or boom. Rated capacities and boom length shall be appropriately reduced as wind velocity approaches or exceeds 20 mph.
12. When making lifts with auxiliary head machinery, the effective length of the boom increases by 2 ft.
13. Power sections of boom must be extended in accordance with boom mode "A" or "B". In boom mode "B" all power sections must be extended or retracted equally.
14. The least stable rated working area depends on the configuration of the crane set up.
15. Rated lifting capacities are based on correct reeving. Deduction must be made for excessive reeving. Any reeving over minimum required (see Wire Rope Capacity) is considered excessive and must be accounted for when making lifts. Use Working Range Diagram to estimate the extra feet of rope then deduct 1 lb. for each extra foot of wire rope before attempting to lift a load.
16. The loaded boom angle combined with the boom length give only an approximation of the operating radius. The boom angle, before loading, should be greater to account for deflection. For main boom capacities, the loaded boom angle is for reference only. For fly capacities, the load radius is for reference only.
17. For fly capacities with main boom length less than 105 ft and greater than 80 ft, the rated capacities are determined by the boom angle using the 105 ft boom and fly chart. For angles not shown use the next lower boom angle to determine the rated capacity.
18. For fly capacities with main boom length less than 80 ft, the rated capacities are determined by the boom angle using the 80 ft boom and fly chart. For angles not shown use the next lower boom angle to determine the rated capacity.
19. The 33 ft boom length structural lifting capacities are based on boom fully retracted. If the boom is not fully retracted, do not exceed capacities shown for the 40 ft boom length.
20. Rated lifting capacities on tires depend on tire capacity, condition of tires, and tire air pressure. On tire capacities require lifting from main boom head only on a smooth and level surface. The boom must be centered over the rear of the crane with two position travel swing lock engaged and the load must be restrained from swinging. Rated lifting capacities on tires are limited to creep and 2.5 mph speed. For correct tire pressure, see Tire Inflation.

DEFINITIONS:

1. Load Radius: Horizontal distance from a projection of the axis of rotation to the supporting surface, before loading, to the center of the vertical hoist line or tackle with load applied.
2. Loaded Boom Angle:  The angle between the boom base section and horizontal with freely suspended load at the rated radius.
3. Working Area: Area measured in a circular arc about the center line of rotation as shown on the Working Area Diagram.
4. Freely Suspended Load: Load hanging free with no direct external force applied except by the hoist line.
5. Side Load: Horizontal side force applied to the lifted load either on the ground or in the air.
6. No Load Stability Limit: The radius or boom angle beyond which it is not permitted to position the boom because the crane can overturn without any load on the hook.
7. Load Factor: Load applied at the boom tip which gives the same moment effect as the boom mass.
8. Creep: Crane movement not exceeding 200 ft in a 30 minute period and 1 mph maximum speed.

BOOM EXTENSION

Boom Mode "A"
Only inner mid section telescopes

Boom Length (ft)

33
40
50
57

Inner Mid Section
288" Stroke

Base Section

Boom Mode "B"
Inner mid, outer mid and tip sections telescope simultaneously.

Boom Length (ft)

33
40
50
60
70
80
90
100
105

Tip Section
288" Stroke

Outer Mid Section
288" Stroke

Inner Mid Section
288" Stroke

Base Section

WINCH PERFORMANCE

Wire Rope Layer	Winch Line Pulls		Drum Rope Capacity (ft)	
	Two Speed Winch		Layer	Total
	Low Speed Available* (lb)	High Speed Available (lb)		
1	13,010	6,418	77	77
2	11,768	5,805	85	162
3	10,742	5,299	93	255
4	9,881	4,874	101	356
5	9,148	4,513	109	465

*Maximum lifting capacity: Type RB Rope=9,080, Type ZB Rope=11,080

WIRE ROPE CAPACITY

Maximum Lifting Capacities Based On Wire Rope Strength			
Parts of Line	5/8"	5/8"	Notes
	Type RB	Type ZB	
1	9,080	11,080	Capacities shown are in pounds and working loads must not exceed the ratings on the capacity charts in the Crane Rating Manual. Study Operator's Manual for wire rope inspection procedures and single part of line applications.
2	18,160	22,160	
3	27,240	33,240	
4	36,320	44,320	
5	45,400	55,400	
6	54,480	66,480	
7	63,560	77,560	
8	72,640	88,640	
9	81,720	—	

LBCE	DESCRIPTION
TYPE RB	18 X 19 Rotation Resistant - Compact Strand, High Strength Preformed, Right Regular Lay
TYPE ZB	36 X 7 Rotation Resistant - Extra Improved Plow Steel - Right Regular Lay

HYDRAULIC CIRCUIT PRESSURE SETTINGS

Function	Pressure (PSI)
Front And Rear Winch	3,100
Outriggers	3,000
Boom Hoist	3,350
Telescope	3,000
Swing	1,500
Steering	2,000
Bumper Outrigger	650
Pilot Control	500

TIRE INFLATION

Tire Size	Operation	Tire Pressure (psi)
12R22.5	Creep	120
	2.5 mph	110

PONTOON LOADINGS

Maximum Pontoon Load:	Maximum Pontoon Ground Bearing Pressure:
61,750 lb	137 psi

CAPACITY DEDUCTIONS FOR AUXILIARY LOAD HANDLING EQUIPMENT

Load Handling Equipment:	lb
Auxiliary Head Attached	100
25-ton quick reeve 3-sheave hook block (see hook block for actual weight)	670
40-ton quick reeve 4-sheave hook block (see hook block for actual weight)	780
8.5-ton hook ball (see hook ball for actual weight)	360
Lifting From Main Boom With:	lb
28.5 ft or 51 ft fly stowed on base (see operation note 4)	0
28.5 ft offset fly erected but not used	2,600
51 ft offset fly erected but not used	4,800
Lifting From 28.5 ft Offset Fly With:	
22.5 ft fly tip erected but not used	PROHIBITED
22.5 ft fly tip stowed on 28.5 ft offset fly	PROHIBITED

Note: Capacity deductions are for Link-Belt supplied equipment only.

WORKING AREAS

HTC on Outriggers

HTC on Tires

Note: These Lines Determine The Limiting Position Of Any Load For Operation Within Working Areas Indicated.

WORKING RANGE DIAGRAM

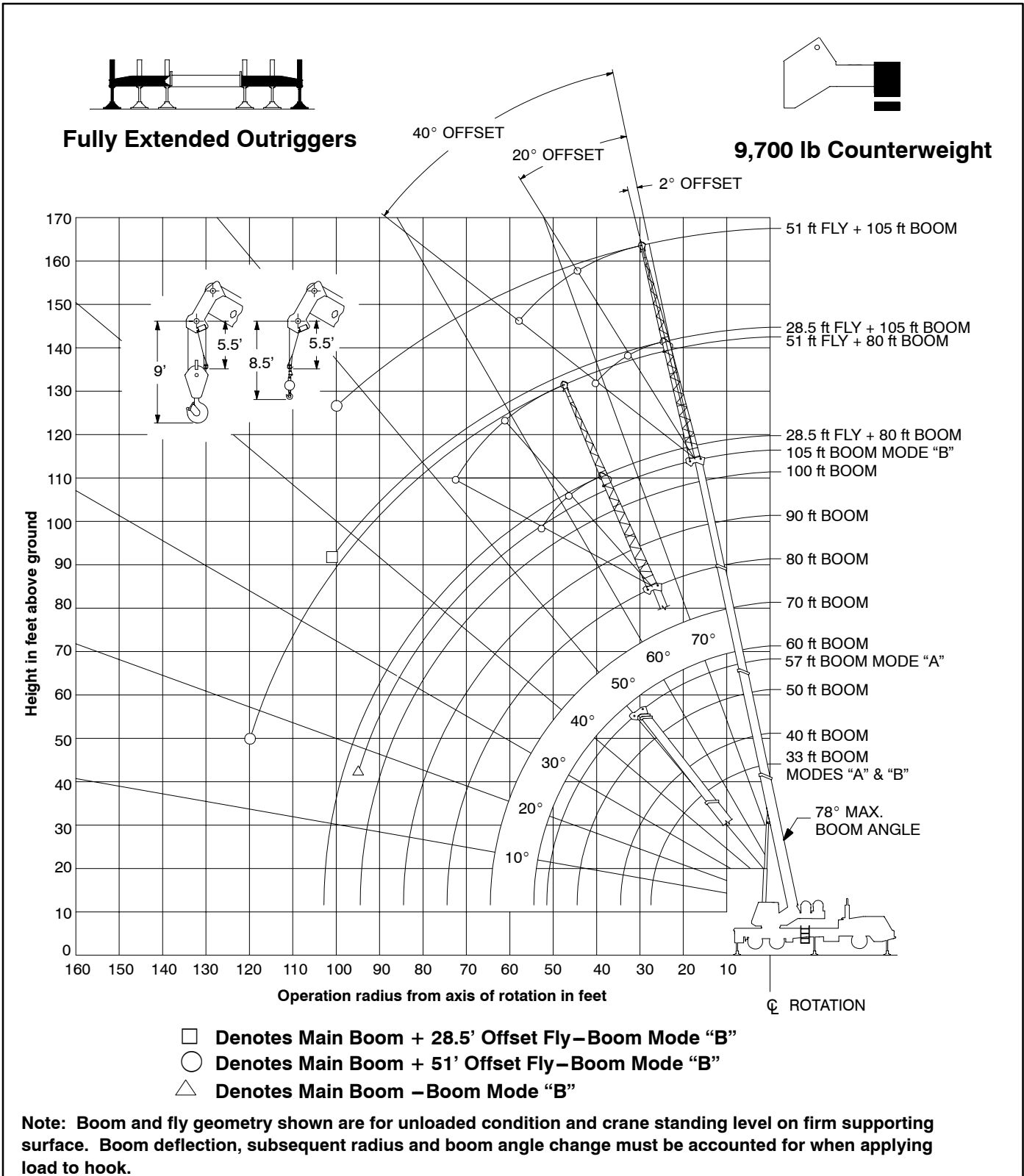

⚠ WARNING

Do Not Lower The Boom Below The Minimum Boom Angle For No Load Stability As Shown In The Lift Charts For The Boom Lengths Given. Loss Of Stability Will Occur Causing A Tipping Condition.

Rated Lifting Capacities In Pounds Fully Extended Outriggers See Set Up Note 2

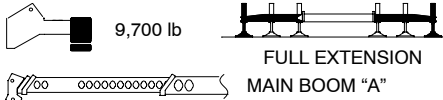

9,700 lb FULL EXTENSION MAIN BOOM "A"

Load Radius (ft)	33 ft			40 ft		
	\angle °	360°	Over Rear	\angle °	360°	Over Rear
9	68.0	80,000	80,000			
10	66.0	72,300	72,300	70.5	72,300	72,300
12	62.0	65,500	65,500	67.5	65,200	65,200
15	55.5	55,600	55,600	62.5	55,300	55,300
20	43.5	42,200	42,200	54.0	41,900	41,900
25	26.5	29,900	29,900	44.0	29,700	29,700
30				31.0	21,500	21,500
Min. Bm. Ang/Cap	0 (27.5)	18,400	18,400	0 (34.5)	14,100	14,100
Load Radius (ft)	50 ft			57 ft		
	\angle °	360°	Over Rear	\angle °	360°	Over Rear
10	75.0	67,500	67,500	77.0	43,800	43,800
12	73.0	61,200	61,200	75.0	43,800	43,800
15	69.0	53,400	53,400	72.0	42,100	42,100
20	62.5	41,600	41,600	66.5	34,300	34,300
25	55.5	29,300	29,300	61.0	28,700	28,700
30	48.0	21,300	21,300	54.5	21,100	21,100
35	39.0	16,100	16,100	47.5	16,000	16,000
40	27.5	12,400	12,400	40.0	12,300	12,300
45				30.5	9,600	9,600
50				16.0	7,600	7,600
Min. Bm. Ang/Cap	0 (44.5)	9,300	9,300	0 (51.5)	6,900	6,900

Note: Refer To "Capacity Deductions For Auxiliary Load Handling Equipment". \angle ° Loaded Boom Angle In Degrees. () Reference Radius For Min. Boom Angle Capacities (Shown In Parenthesis) Are In Feet.

Rated Lifting Capacities In Pounds Fully Extended Outriggers See Set Up Note 2

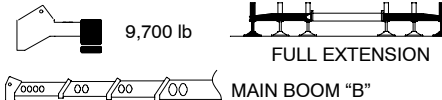

9,700 lb FULL EXTENSION MAIN BOOM "B"

Load Radius (ft)	33 ft			40 ft			50 ft		
	\angle °	360°	Over Rear	\angle °	360°	Over Rear	\angle °	360°	Over Rear
9	68.0	80,000	80,000						
10	66.0	72,300	72,300	70.5	35,000	35,000	74.5	35,000	35,000
12	62.0	65,500	65,500	67.5	35,000	35,000	72.5	35,000	35,000
15	55.5	55,600	55,600	62.5	35,000	35,000	68.5	35,000	35,000
20	43.5	42,200	42,200	54.0	35,000	35,000	62.5	35,000	35,000
25	26.5	29,900	29,900	43.5	30,700	30,700	55.5	31,100	31,100
30				31.0	22,400	22,400	47.5	23,000	23,000
35							39.0	17,700	17,700
40							27.5	14,000	14,000
Min. Bm. Ang/Cap	0 (27.5)	18,400	18,400	0 (34.5)	13,500	13,500	0 (44.5)	9,200	9,200
Load Radius (ft)	60 ft			70 ft			80 ft		
	\angle °	360°	Over Rear	\angle °	360°	Over Rear	\angle °	360°	Over Rear
10	77.5	35,000	35,000						
12	75.5	35,000	35,000						
15	72.5	35,000	35,000	75.5	35,000	35,000			
20	67.5	35,000	35,000	71.5	35,000	35,000			
25	62.5	31,400	31,400	67.0	31,500	31,500	74.5	30,700	30,700
30	56.5	23,200	23,200	62.5	23,400	23,400	67.0	26,400	26,400
35	50.5	18,000	18,000	57.5	18,100	18,100	62.5	22,900	22,900
40	43.5	14,300	14,300	52.0	14,500	14,500	58.5	18,200	18,200
45	35.5	11,600	11,600	46.5	11,800	11,800	53.5	14,600	14,600
50	25.0	9,500	9,500	40.0	9,700	9,700	49.0	11,900	11,900
55				33.0	8,100	8,100	43.5	9,900	9,900
60				23.0	6,700	6,700	37.5	8,200	8,200
65							31.0	6,800	6,800
70							22.0	5,700	5,800
75								4,700	4,800
80									
85									
90									
95									
Min. Bm. Ang/Cap	0 (54.5)	6,500	6,500	0 (64.5)	4,600	4,600	0 (74.5)	3,300	3,300
Load Radius (ft)	90 ft			100 ft			105 ft		
	\angle °	360°	Over Rear	\angle °	360°	Over Rear	\angle °	360°	Over Rear
20	77.0	27,400	27,400						
25	73.5	23,500	23,500	76.0	21,000	21,000	76.5	17,500	17,500
30	70.0	20,500	20,500	73.0	18,700	18,700	74.0	17,500	17,500
35	66.5	18,100	18,100	70.0	16,500	16,500	71.0	15,700	15,700
40	63.0	14,700	14,700	66.5	14,600	14,600	68.0	13,800	13,800
45	59.0	12,000	12,000	63.0	12,000	12,000	65.0	12,100	12,100
50	55.0	9,900	9,900	59.5	10,000	10,000	61.5	10,000	10,000
55	50.5	8,300	8,400	56.0	8,400	8,400	58.5	8,400	8,400
60	46.0	6,900	7,000	52.5	7,000	7,100	55.0	7,000	7,100
65	41.5	5,800	5,900	48.5	5,800	6,000	51.0	5,900	6,000
70	35.5	4,800	4,900	44.0	4,900	5,000	47.0	4,900	5,100
75	29.5	4,000	4,100	39.5	4,100	4,200	43.0	4,100	4,300
80	21.0	3,300	3,400	34.0	3,400	3,500	38.5	3,400	3,600
85				28.0	2,800	2,900	33.5	2,800	3,000
90				20.0	2,200	2,400	27.5	2,200	2,400
95							19.5	1,800	2,000
Min. Bm. Ang/Cap	0 (84.5)	2,300	2,300	0 (94.5)	1,500	1,500	17.0 (96.3)		

Note: Refer To "Capacity Deductions For Auxiliary Load Handling Equipment". \angle ° Loaded Boom Angle In Degrees. () Reference Radius For Min. Boom Angle Capacities (Shown In Parenthesis) Are In Feet.

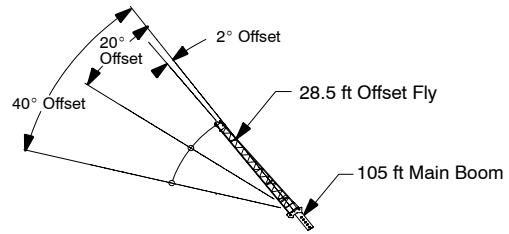
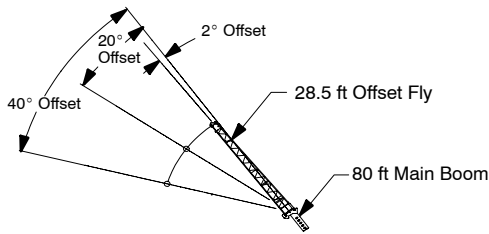

Rated Lifting Capacities In Pounds Fully Extended Outriggers See Set Up Note 2

FULL EXTENSION 9,700 lb

Load Radius (ft)	2° Offset		20° Offset		40° Offset	
	∠°	360°	∠°	360°	∠°	360°
25	77.0	15,200				
30	74.5	13,900				
35	72.0	11,900	76.0	8,700		
40	69.0	11,000	73.0	8,100	77.0	6,100
45	66.0	10,300	70.0	7,600	74.0	5,800
50	63.0	9,600	67.0	7,100	71.0	5,600
55	60.0	8,900	64.0	6,700	67.5	5,400
60	57.0	7,900	61.0	6,400	64.0	5,300
65	53.5	6,700	57.5	6,000	60.5	5,100
70	49.5	5,800	54.0	5,800	57.0	5,000
75	45.5	4,900	50.0	5,300	52.5	4,900
80	41.5	4,200	45.5	4,500	48.0	4,700
85	37.0	3,600	41.0	3,800	42.5	3,900
90	31.5	3,000	35.5	3,200		
95	25.5	2,500	28.5	2,700		
100	16.5	2,100	18.5	2,200		
Min. Bm. Ang./Cap.	0	1,300	0	1,400	0	1,500

Rated Lifting Capacities In Pounds Fully Extended Outriggers See Set Up Note 2

FULL EXTENSION 9,700 lb

Load Radius (ft)	2° Offset		20° Offset		40° Offset	
	∠°	360°	∠°	360°	∠°	360°
35	76.5	9,000				
40	74.5	9,000	78.0*	7,900		
45	72.5	8,800	76.0	7,500		
50	70.0	7,900	73.5	7,200	76.5	5,700
55	67.5	7,200	71.0	6,600	74.0	5,500
60	65.5	6,600	69.0	6,100	71.5	5,400
65	63.0	6,100	66.5	5,700	69.5	5,200
70	60.5	5,500	64.0	5,300	66.5	5,000
75	57.5	4,700	61.0	4,900	64.0	4,700
80	54.5	4,000	58.5	4,400	61.0	4,400
85	51.5	3,300	55.0	3,700	58.0	4,000
90	48.5	2,800	52.0	3,100	54.5	3,300
95	45.0	2,300	48.5	2,600	51.0	2,800
100	41.5	1,900	45.0	2,100	47.0	2,300
105	38.0	1,500	41.0	1,700	42.5	1,800

WARNING

Do Not Lower 28.5 ft Offset Fly In Working Position Below 37° Main Boom Angle Unless Main Boom Length Is 86 ft Or Less, Since Loss Of Stability Will Occur Causing A Tipping Condition.

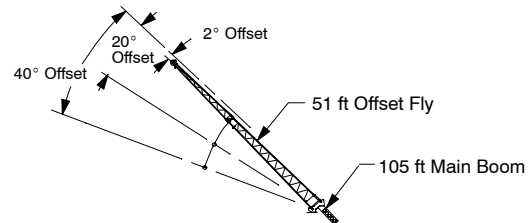
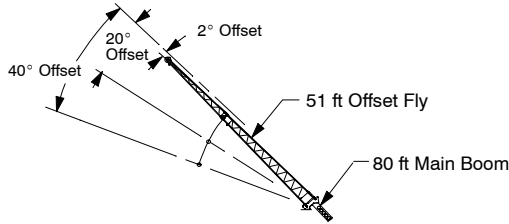

Rated Lifting Capacities In Pounds Fully Extended Outriggers See Set Up Note 2

FULL EXTENSION 9,700 lb

Load Radius (ft)	2° Offset		20° Offset		40° Offset	
	∠°	360°	∠°	360°	∠°	360°
35	76.0	7,400				
40	74.0	6,700				
45	71.5	6,100	78.0*	4,200		
50	69.5	5,600	76.0	3,900		
55	67.0	5,100	73.5	3,700		
60	64.5	4,700	71.0	3,500	77.0	2,700
65	62.0	4,300	68.5	3,300	74.5	2,600
70	59.5	4,000	66.0	3,100	72.0	2,500
75	57.0	3,800	63.0	2,900	69.0	2,400
80	54.0	3,500	60.5	2,800	66.0	2,300
85	51.0	3,300	57.5	2,700	62.5	2,300
90	48.0	3,100	54.5	2,600	59.5	2,200
95	45.0	2,900	51.0	2,500	55.5	2,200
100	41.5	2,700	47.5	2,400	51.5	2,200
105	37.5	2,300	43.5	2,300	47.0	2,100
110	33.0	2,000	39.0	2,200	41.5	2,100
115	28.0	1,600	33.5	1,800		
120	22.0	1,400	26.5	1,500		

WARNING

Do Not Lower 51 ft Offset Fly In Working Position Below 17° Main Boom Angle Unless Main Boom Length Is 78 ft Or Less, Since Loss Of Stability Will Occur Causing A Tipping Condition.

Rated Lifting Capacities In Pounds Fully Extended Outriggers See Set Up Note 2

FULL EXTENSION 9,700 lb

Load Radius (ft)	2° Offset		20° Offset		40° Offset	
	∠°	360°	∠°	360°	∠°	360°
40	77.5	5,800				
45	75.5	5,700				
50	74.0	5,400				
55	72.0	5,100	77.5	3,700		
60	70.5	4,800	75.5	3,500		
65	68.5	4,500	73.5	3,400		
70	66.5	4,200	71.5	3,200	76.5	2,500
75	64.5	3,900	69.5	3,100	74.5	2,400
80	62.0	3,600	67.5	2,900	72.5	2,400
85	60.0	3,300	65.5	2,800	70.5	2,300
90	58.0	3,000	63.5	2,700	68.0	2,300
95	55.5	2,800	61.0	2,600	65.5	2,200
100	53.0	2,300	58.5	2,500	63.0	2,200
105	50.0	1,900	56.0	2,300	60.5	2,200
110			53.5	2,000	57.5	2,100
115			50.5	1,600	54.5	1,900
120					51.0	1,500

WARNING

Do Not Lower 51 ft Offset Fly In Working Position Below 47.5° Main Boom Angle Unless Main Boom Length Is 78 ft Or Less, Since Loss Of Stability Will Occur Causing A Tipping Condition.

Note: Refer To "Capacity Deductions For Auxiliary Load Handling Equipment". ∠° Loaded Boom Angle In Degrees. * This Capacity Based On Maximum Obtainable Boom Angle.

Note: Refer To "Capacity Deductions For Auxiliary Load Handling Equipment". ∠° Loaded Boom Angle In Degrees. * This Capacity Based On Maximum Obtainable Boom Angle.

This page intentionally left blank

This page intentionally left blank

This page intentionally left blank

Link-Belt Construction Equipment Company Lexington, Kentucky www.linkbelt.com

®Link-Belt is a registered trademark. Copyright 2004. We are constantly improving our products and therefore reserve the right to change designs and specifications.